

*PHOTOELECTRIC
SAFETY
BARRIER*

SLC 210 / SLG 210

MOUNTING AND WIRING INSTRUCTIONS

TABLE OF CONTENTS

INTRODUCTION.....	2
OPERATION	3
INSTALLATION.....	4
POSITIONING.....	5
SAFETY DISTANCE CALCULATION	6
VERTICAL POSITION OF THE BARRIER	7
HORIZONTAL POSITION OF THE BARRIER	8
ELECTRICAL CONNECTIONS	9
MULTIPLE SYSTEMS	12
DISTANCE BETWEEN REFLECTING SURFACES	12
USE OF DEFLECTION MIRRORS	14
MECHANICAL ASSEMBLY AND OPTIC ALIGNMENT	15
OPERATION AND TECHNICAL DATA.....	16
SIGNALS	16
TEST FUNCTION.....	17
OUTPUTS STATUS	17
TECHNICAL SPECIFICATIONS	18
DIMENSIONS	19
CHECKS AND MAINTENANCE	21
TROUBLESHOOTING	22
SPARE PARTS	23



This symbol indicates a very important warning concerning the safety of persons. Its non-observance can cause a very serious risk for the exposed personnel.

INTRODUCTION

The SLC 210 / SLG 210 photoelectric barrier is an optoelectronic safety system. It belongs to the family of Type 2 electrosensitive devices according to EN 954-1.

The SLC 210 / SLG 210 barrier, which consists of an Emitter and a Receiver, is a type 2 optoelectronic safety device according to standards IEC 61496-1 and IEC 61496-2.

SLC 210 / SLG 210 is available in two different families of models depending on the maximum working range : 6 m (standard model) and 16 m (models with the extension “-L”).

The two safe semiconductor outputs enable the barrier to be connected to the SCR 1R safety modules, to a safety PLC or to another control system that satisfies the specific requirements and safety level of the application.

SLC 210 / SLG 210 is ideal for protecting:

Machinery for product handling such as conveyors, palletizing, collating machines; packaging and wrapping devices; automated assembly lines; automated warehousing.



If necessary, contact the competent safety authorities in the country of use for any safety-related problems questions.



For applications in the food industry, please contact the manufacturer to ensure that the barrier contains materials that are compatible with the chemical agents utilized.

The protective function of the optoelectronic devices is not effective in the following cases:



If the machine stopping control cannot be actuated electrically and if it is not possible to stop all dangerous machine movements immediately and at any time during the operating cycle.



If the machine generates dangerous situations due to material being expelled or falling from overhead.

OPERATION

If the protected area is clear, the two outputs on the Receiver are active.

Each time that an object bigger than or equal in size to the resolution of the system intercepts the optical path of one or more beams, the Receiver deactivates the outputs.



The resolution is the minimum dimensions that an object must have to intercept at least one of the optical beams generated by the barrier (Figure 1).

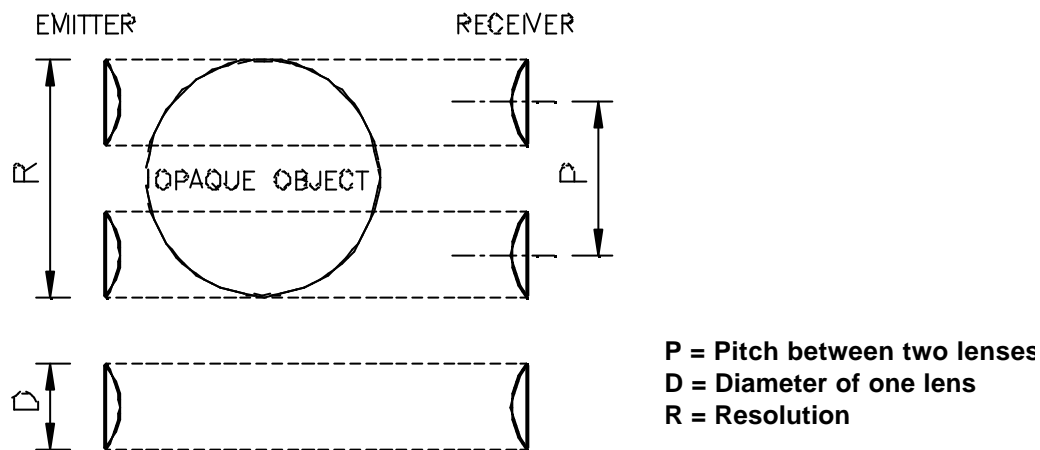

Figure 1

The resolution is constant irrespectively of work conditions, as it only depends on the geometric characteristics of the lenses and the distance between the centres of two adjacent lenses.

The **height of the protected area** is the height that is actually protected by the safety barrier. If the latter is placed horizontally, this value refers to the depth of the protected area.

The **working range** is the maximum operative distance that can exist between the Emitter and the Receiver.

SLC 210 / SLG 210 is available with the following resolutions:





- 20 mm (protected height from 160 mm to 1800 mm)
PROTECTION OF FINGERS
- 40 mm (protected height from 310 mm to 1800 mm)
PROTECTION OF HANDS
- 90 mm (protected height from 460 mm to 1800 mm)
PROTECTION OF BODY

SLG 210 is the Multibeam configuration with the following lens pitch:



- 500 mm (2 beams), 400 mm (3 beams), 300 mm (4 beams)
PROTECTION OF BODY

INSTALLATION

Before installing the SLC 210 / SLG 210 safety system, make sure that:

-  ***The safety system is only used as a stopping device and not as a machine control device.***
-  ***The machine control can be actuated electrically.***
-  ***All dangerous machine movements can be interrupted immediately. In particular, the machine stopping times must be known and, if necessary, measured.***
-  ***The machine does not generate dangerous situations due to materials projecting or falling from overhead; if that is not the case, additional mechanical guards must be installed.***
-  ***The minimum dimensions of the object that must be intercepted are greater than or equal to the resolution of the specific model.***

The general instructions set out below must be taken into consideration before placing the safety device in position.

-  ***Make sure that the temperature of the environment in which the system is to be installed is compatible with the temperature parameters contained in the technical data sheet.***
-  ***Do not install the Emitter and Receiver close to bright light sources.***
-  ***Certain environmental conditions may affect the monitoring capacity of the photoelectric devices. In order to assure correct operation of equipment in places that may be subject to fog, rain, smoke or dust, the appropriate correction factors Cf should be applied to the maximum working range values. In these cases:***

$$P_u = P_m \times C_f$$

where P_u and P_m are, respectively, the working and maximum range in meters (see following table).

The recommended Cf factors are shown in the table below:

ENVIRONMENTAL CONDITION	CORRECTION FACTOR Cf
Fog	0.25
Steam	0.50
Dust	0.50
Dense fumes	0.25



If the device is installed in places that are subject to sudden changes in temperature, the appropriate precautions must be taken in order to prevent the formation of condensation on the lenses, which could have an adverse effect on monitoring.

POSITIONING

The position of the Emitter and the Receiver must prevent access to the danger zone unless at least one of the optical beams has been intercepted. Some useful information regarding the correct position of the barrier is shown in the figure below.

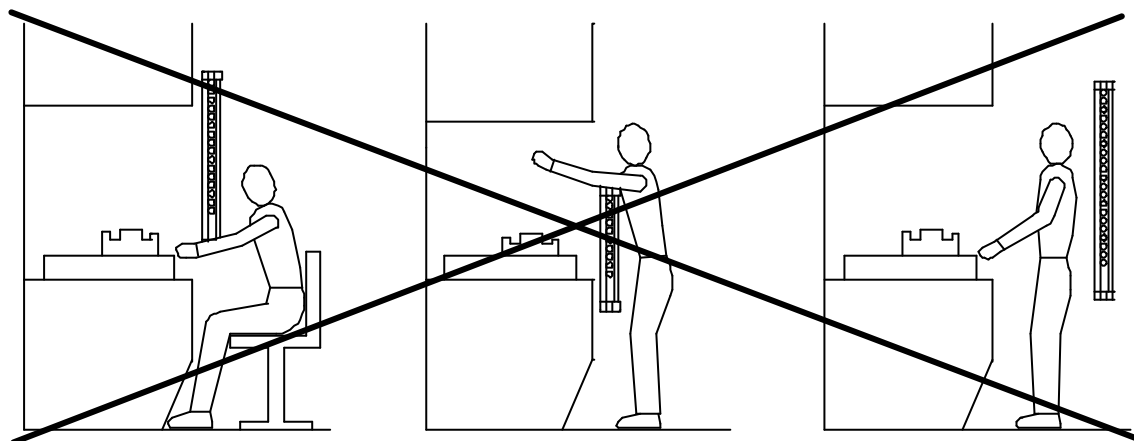

Incorrect positioning of barrier

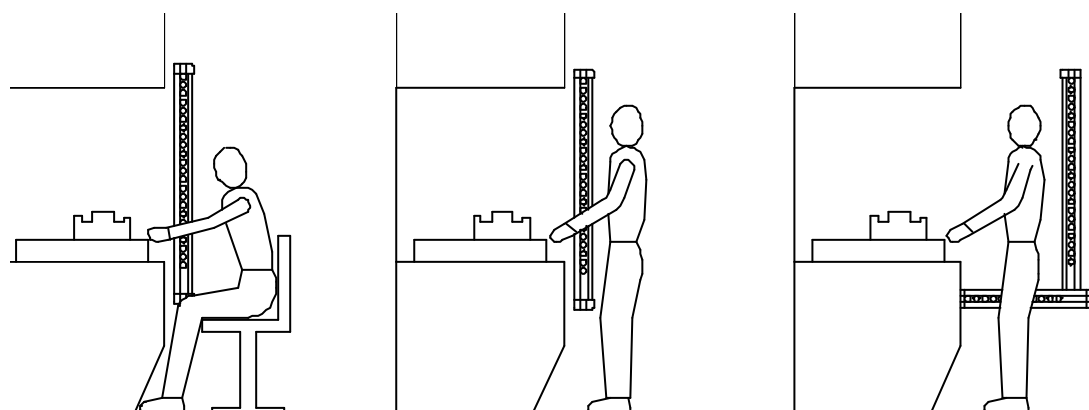

Correct positioning of barrier

Figure 2

SAFETY DISTANCE CALCULATION

The barrier must be installed at a distance that is greater than or equal to the **minimum safety distance S**, so that a dangerous point can only be reached after all hazardous machine movements have stopped (Figure 3).

According to European standard EN999, the minimum safety distance **S** must be calculated using the following formula:

$$S = K (t_1 + t_2 + t_3) + C$$

where:

Symbol	Meaning	Unit
S	<i>minimum safety distance</i>	mm
K	<i>approach speed of object to the dangerous area</i>	mm/sec
t₁	<i>response time of the safety barrier in seconds</i>	sec
t₂	<i>response time of the safety interface in seconds (e.g. PLC or safety module*)</i>	sec
t₃	<i>machine response time, in seconds, meaning the time required for the machine to interrupt the dangerous movement following transmission of the stop signal</i>	sec
c	<i>additional distance</i>	mm

* t₂ SCR 1R ≤ 20 msec (refer to the technical manual of each single safety module, if different from SCR 1R).

 **The non-observance of the correct safety distance reduces or cancels the protective action of the light curtain.**

 **If the position of the barrier does not prevent the operator from having access to the dangerous area without being detected, additional mechanical guards must be installed to complete the system.**

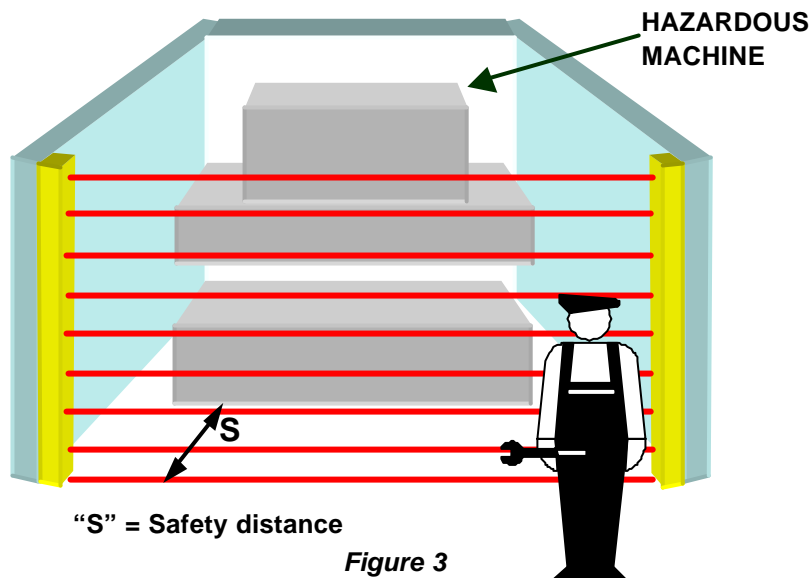

Figure 3

VERTICAL POSITION OF THE BARRIER



20 mm resolution models

These models are suitable for the protection of fingers.

$$S = K (t_1 + t_2 + t_3) + C \text{ and } S \geq 100 \text{ mm}$$



40 mm resolution models

These models are suitable for the protection of hands.

The minimum safety distance **S** is calculated according to the following formula:

$$S = K (t_1 + t_2 + t_3) + C$$

If $S \leq 500 \text{ mm}$, then $K = 2000 \text{ mm / sec}$

If $S > 500 \text{ mm}$, then $K = 1600 \text{ mm / sec}$

$$C = 8 (D - 14); (D = \text{resolution})$$

If, due to the specific configuration of the machine, the dangerous area can be accessed from above, the highest beam of the barrier must be at a height **H** of at least 1800 mm from the base **G** of the machine.

$$S \geq 150 \text{ mm}$$

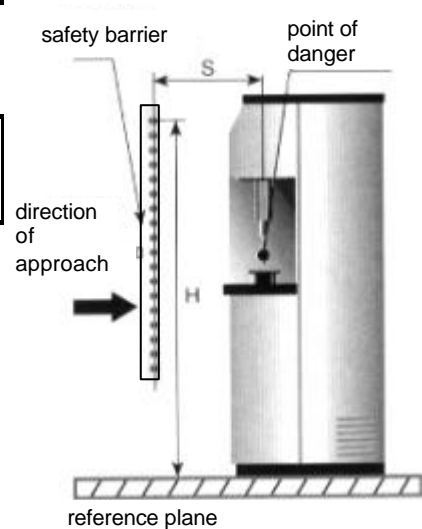

Figure 4

90 mm resolution models



These models are suitable for the protection of arms or legs and must not be used to protect fingers or hands.

The minimum safety distance **S** is calculated according to the following formula:

$$S = K (t_1 + t_2 + t_3) + C$$

$K = 1600 \text{ mm/sec}$

$C = 850 \text{ mm}$



The height **H** of the highest beam from the base **G** must never be less than 900 mm, while the height of the lowest beam **P** must never be more than 300 mm.

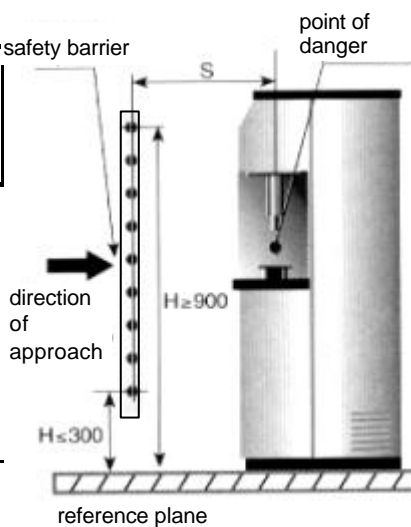

Figure 5

Multibeam Mode ^{point of danger}



safety barrier **These models are suitable for the protection of the entire body and must not be used to protect arms or legs.**

The minimum safety distance **S** is calculated according to the following formula:

$$S = K (t_1 + t_2 + t_3) + C$$

K = 1600 mm/sec

C = 850 mm

direction of approach

reference plane

The recommended height **H** from the base (G) must be the following:

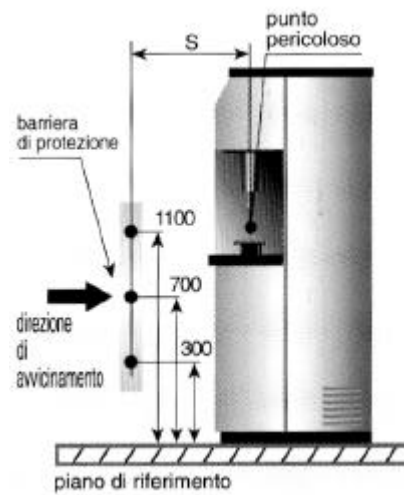

Figure 6

MODEL	BEAMS	Recommended Height H (mm)
SLG 210-E/R0500-02-12(-H)	2	400 – 900
SLG 210-E/R0800-03-12(-H)	3	300 – 700 – 1100
SLG 210-E/R0900-04-12(-H)	4	300 – 600 – 900 - 1200

HORIZONTAL POSITION OF THE BARRIER

When the object ^{point of danger} on of approach is parallel to the floor of the protected area, the barrier must be installed so that the distance between the outer limit of the dangerous area and the most external optical direction is greater than or equal to the minimum safety distance **S** calculated as follows:

$$S = K (t_1 + t_2 + t_3) + C$$

K = 1600 mm/sec

safety barrier = 1200 – 0.4 H (but > 850 mm)

where H is the height of the protected surface from the base of the machine;

$$H = 15 (D - 50) \text{ (D = resolution)}$$

reference plane



Figure 7

ELECTRICAL CONNECTIONS

WARNINGS

Before making the electrical connections, make sure that the supply voltage complies with the one specified in the technical data sheet.



Emitter and Receiver units must be supplied with PELV type 24 V_{DC} ± 20% power supply (e.g. by means of an insulating transformer according to EN 60724).

The external power supply must comply with EN 60204 (it can bridge short-term mains failures of up to 20 msec).

Connector pins

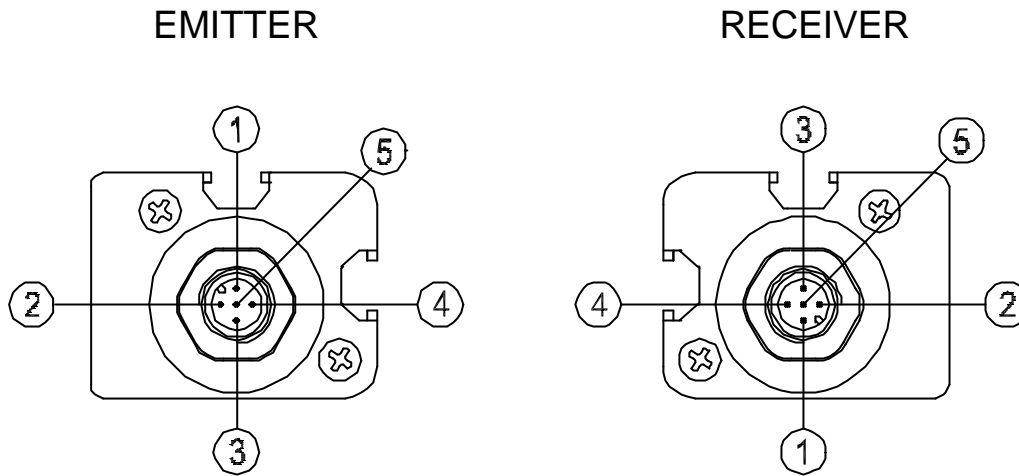

Figure 8

EMITTER		
NUMBER	NAME	MEANING
1	24 V _{DC}	Power supply (positive)
2	TEST	- Operation without TEST (+24 V _{DC}) - TEST control (Transition +24 V _{DC} -> 0 V _{DC} or open circuit)
3	0 V _{DC}	Power supply (negative)
4	N.C.	N.C.
5	PE	Ground connection

Table 1

⚡ If the TEST function is not required by the application, connect pin 2 of the emitter to +24 V_{DC}.

RECEIVER		
NUMBER	NAME	MEANING
1	24 V _{DC}	Power supply (positive)
2	OSSD1	Semiconductor output No. 1 (PNP active high)
3	0 V _{DC}	Power supply (negative)
4	OSSD2	Semiconductor output No. 2 (PNP active high)
5	PE	Ground connection

Table 2

**Example of connection of the SLC 210 / SLG 210
barrier to the SCR 1R safety module**

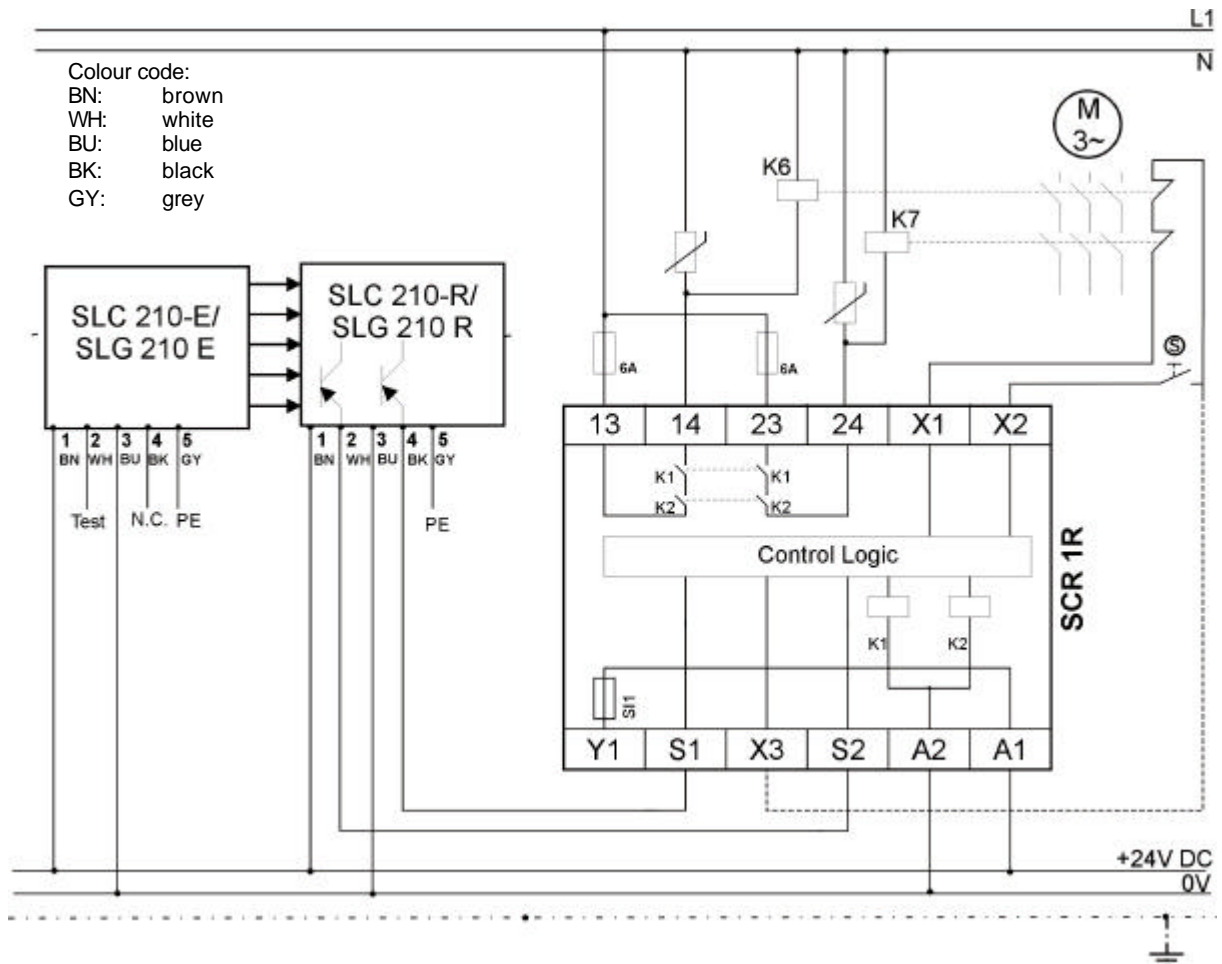

Figure 9

Instructions for connection cables

- For connections over 50 m long, use cables with a cross-section area of 1 mm².
- Connect the Emitter and the Receiver to the ground outlet.
- The connection cables must follow a different route to that of the other power cables.

MULTIPLE SYSTEMS

When more than one SLC 210 / SLG 210 system is used, precautions must be taken to avoid optical interference between them: install units so that the beam emitted by the Emitter of one system can only be received by the relative Receiver.

Figure 11 illustrates some examples of correct positioning when two photoelectric systems are installed. Incorrect positioning could generate interference, and may result in malfunctioning.

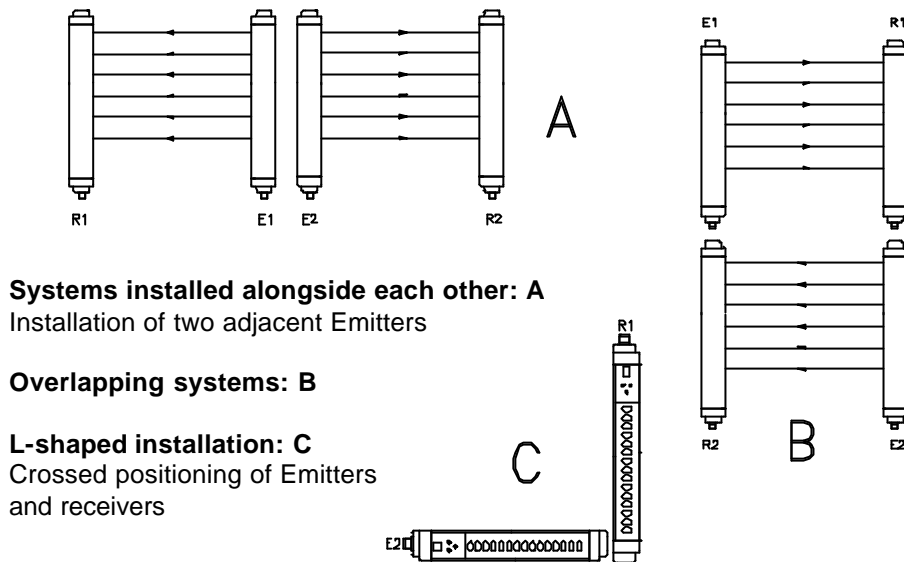

Figure 10

Whenever it is possible (depending on the application), we suggest to utilize the models with a working range of 6 m.

DISTANCE BETWEEN REFLECTING SURFACES

The presence of reflecting surfaces in proximity of the photoelectric barrier may generate spurious reflections that prevent monitoring. With reference to Figure 12, object **A** is not detected because surface **S** reflects the beam and closes the optical path between the Emitter and Receiver.

A minimum distance **d** (distance between A and surface S) must therefore be maintained between any reflecting surfaces and the protected area. The minimum distance **d** must be calculated according to the distance **l** between the Emitter and the Receiver, considering that the angle of projection and reception is $\pm 4^\circ$.

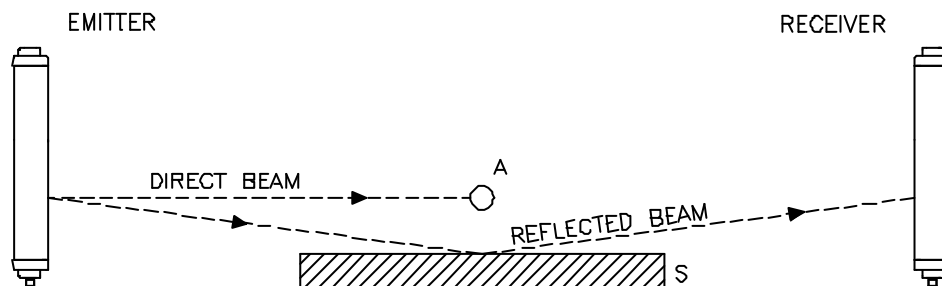

Figure 11

Figure 12 illustrates the values for the minimum distance d that must be maintained when the distance l between the Emitter and Receiver is changed.

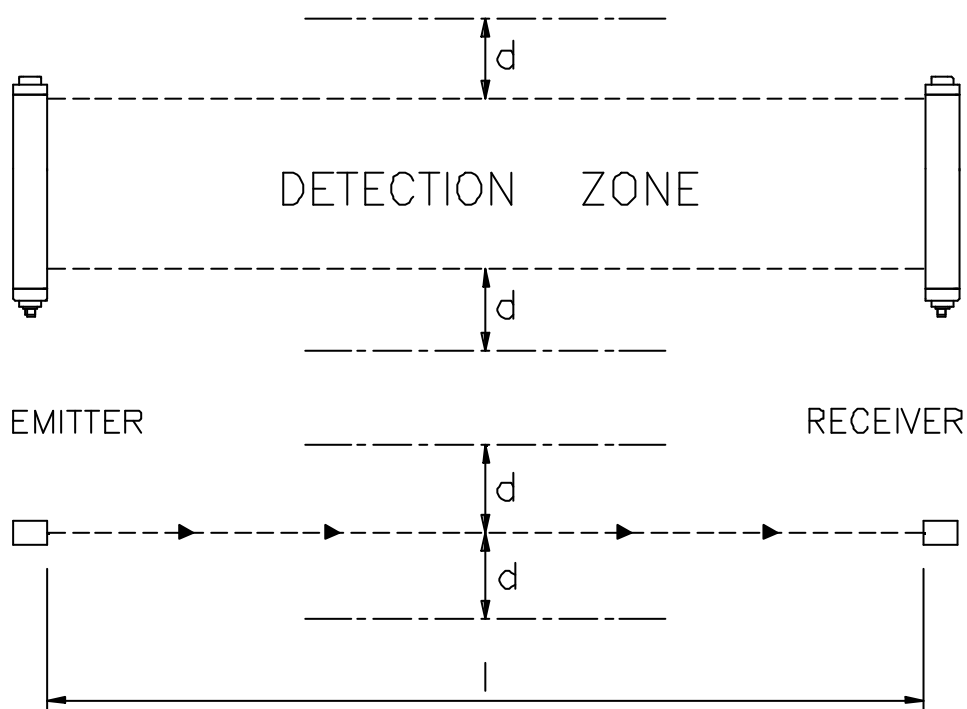
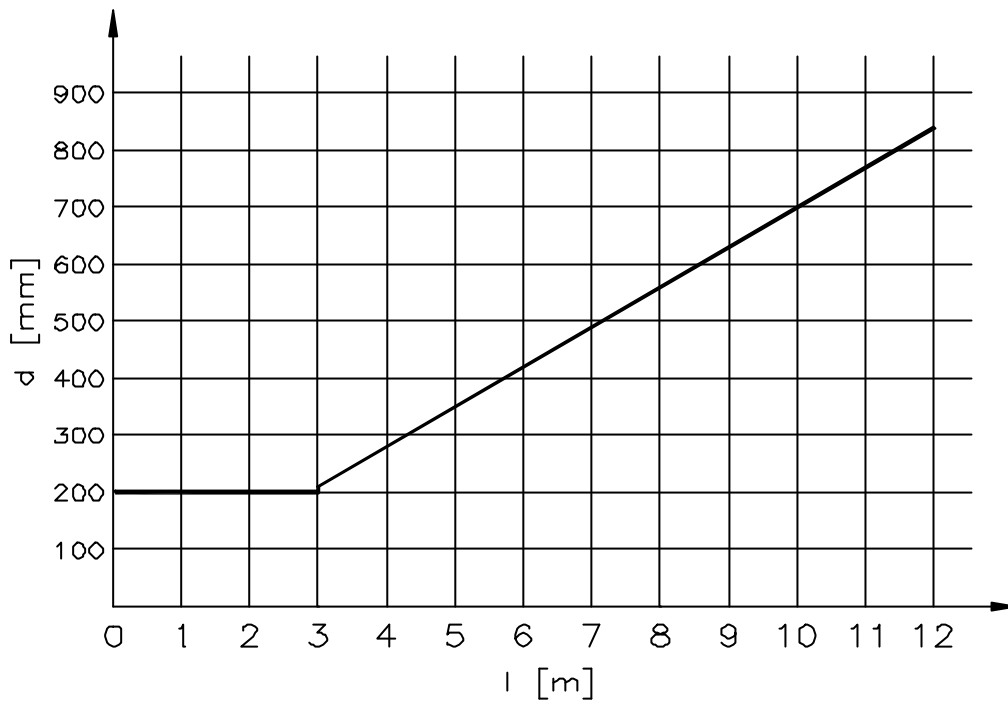

Figure 12

After installing the system, check whether any reflecting surfaces intercept the beams, first in the centre and then close to the Emitter and Receiver.

USE OF DEFLECTION MIRRORS

In order to protect or control areas that can be accessed from more than one side, to the Emitter and Receiver in addition, one or more deflection mirrors can be installed.

These mirrors enable the optical beams generated by the Emitter to be deviated on one or more sides.

If the beams emitted by the Emitter must be deviated by 90°, the perpendicular to the surface of the mirror must form an angle of 45° with the direction of the beams.

The following figure illustrates an application in which two deviation mirrors are used to provide a U-shaped protection.

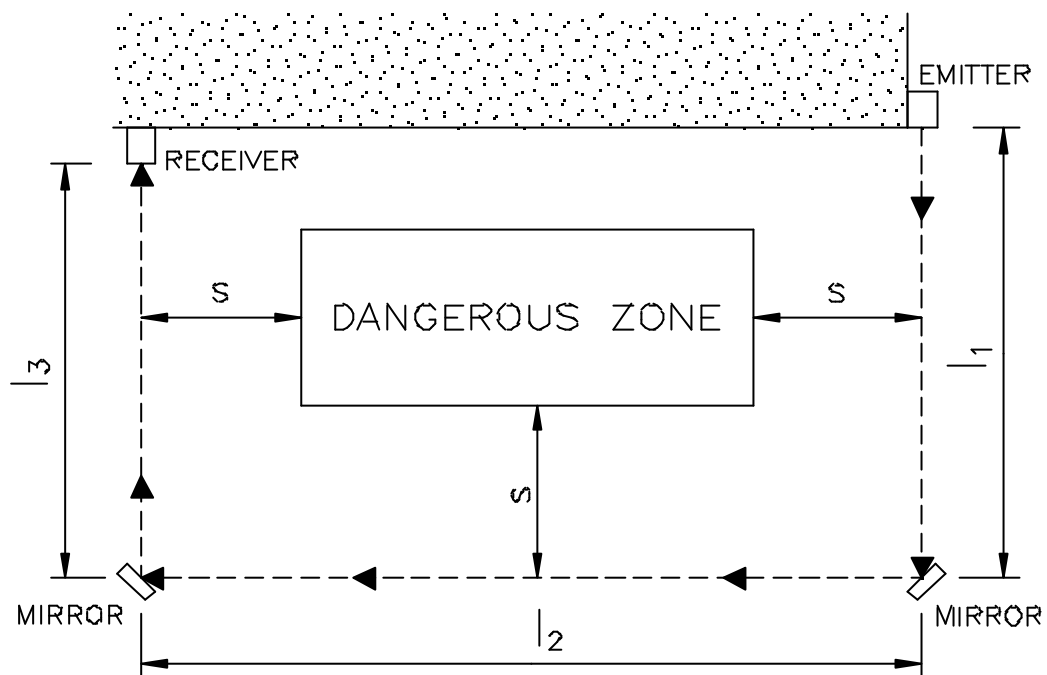

Figure 13

The following rules should be taken into consideration when using deviation mirrors:

- Place the mirrors so as to ensure compliance with the minimum safety distance **S** (Figure 13) on every side from which the danger zone can be accessed.
- The working distance (range) is given by the sum of the lengths of all the sides that give access to the protected area. (Remember that for each mirror used the maximum working range between the Emitter and the Receiver is reduced by 15%).
- During installation, take great care to avoid twisting along the longitudinal axis of the mirror.
- The use of more than three deviation mirrors is not recommended.

MECHANICAL ASSEMBLY AND OPTIC ALIGNMENT

The Emitter and the Receiver must be assembled opposite each other. Use the fastening brackets and inserts supplied with the system to place the Emitter and the Receiver so that these are aligned and parallel to each other and with the connectors facing the same way.

Perfect alignment of the Emitter and Receiver is essential in order to assure correct barrier operation. The indicator LEDs on the Emitter and Receiver facilitate this operation.

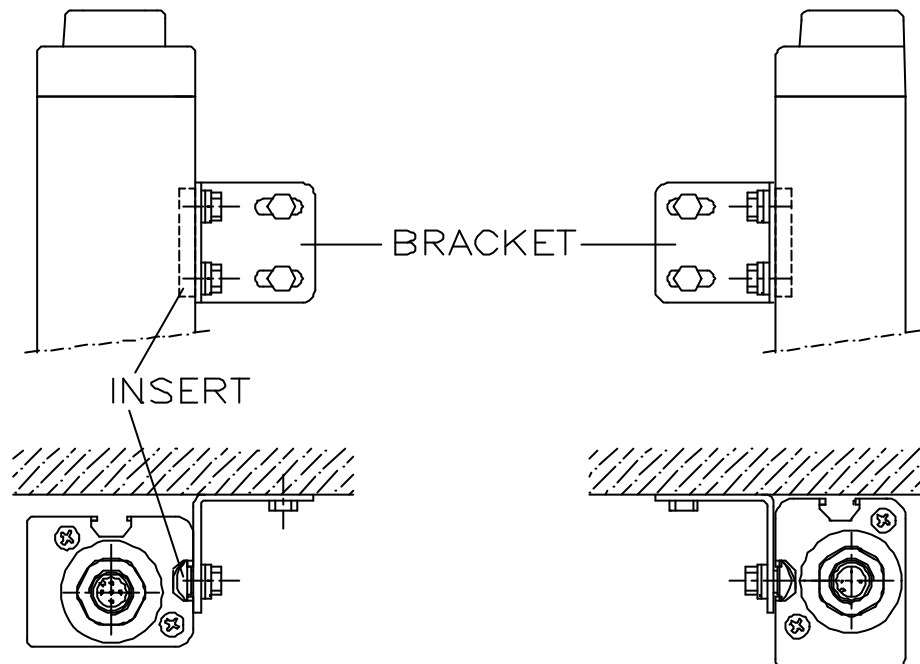

Figure 14

- Position the optical axis of the first and last beam of the Emitter on the same axis as that of the corresponding beams on the Receiver.
- Move the Emitter in order to find the area within which the green LED on the Receiver stays on, then position the first beam of the Emitter (the one close to the indicator LEDs) in the centre of this area.
- Using this beam as a pivot, effect small sideways movements within the protected area. The green LED on the Receiver will light up if the protected area is clear.
- Lock the Emitter and Receiver in place.

During these operations it may be useful to check the **yellow weak signal LED** on the Receiver. Upon completion of alignment, this LED must be off.

If the Emitter and the Receiver are assembled in areas that are subject to strong vibrations, the use of vibration-damping supports is recommended, in order to prevent circuit malfunctions.

OPERATION AND TECHNICAL DATA

SIGNALS

Emitter	LED	COLOUR	STATUS	MEANING
	1	Yellow	On	System activated. Initial TEST
	2	Red	On	
	1	Yellow	On	TEST condition
	3	Green	On	
	3	Green	On	Normal operation
2	Red	On	Malfunction	

Receiver	LED	COLOUR	STATUS	MEANING
	4	Yellow	On	System activated
	5	Red	On	
	6	Red	On	
	7	Green	On	Protected area clear
	5	Red	On	Protected area engaged
	4	Yellow	On	Weak signal received
	4	Yellow	Blinking	Detection of hazardous interfering emitter condition
	6	Red	On	Overcurrent on one or both outputs (OSSD)
	6	Red	Blinking	Erroneous connection of semiconductor outputs (OSSD)
4 6	Yellow Red	Blinking	Internal fail detected	

NOTE: For a more detailed description of the signalings in case of FAIL, please refer to the "TROUBLESHOOTING" paragraph in this manual (page 22).

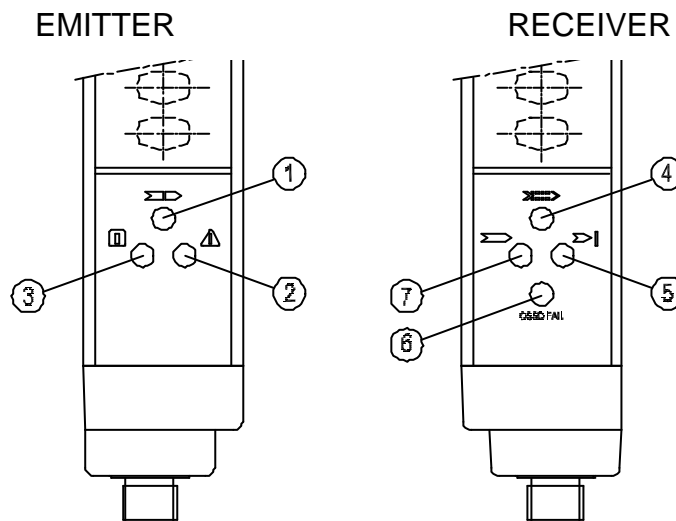

Figure 15

➔ On the emitter of the multibeam models, near each beam is a red LED which permits an easy detection of the beam.

TEST FUNCTION



The SLC 210 / SLG 210 barrier system does not dispose of a start/restart interlock circuit. In most applications this safety function is necessary. The safety module SCR 1R permits to implement this function in a safe way according to IEC 61496-1. Please consider the risk-analysis of your application about this matter.

The SLC 210 / SLG 210 barrier system features an automatic self-diagnosis function that enables it to detect response time malfunctions (in an execution time less than **500 msec**). This safety system is permanently active and does not require any interventions from the outside.

The TEST function is available (bringing the voltage on the **pin 2** of the emitter to 0 V_{DC}) should the user wish to check equipment connected downstream of the barrier (without physically entering the protected area).

By means of the test function, which simulates occupation of the protected area, it is possible to verify the operation of the entire system by means of an external supervisor (e.g. PLC, control module, etc.).

The minimum duration of the TEST function must be 80 msec.

By means of this function the OSSDs can be switched from ON to OFF as long as the function remains active.

OUTPUTS STATUS

The SLC 210 / SLG 210 features two semiconductor outputs on the Receiver, the status of which depends on the condition of the protected area.

The maximum load allowed is 500 mA at 24 V_{DC}, which corresponds to a resistive load of 48 Ω. Maximum load capacity corresponds to 2.2 μF. Any short circuit between outputs or between outputs and 24 V_{DC} or 0 V_{DC} power supplies is detected by the barrier.



In the condition "protected area clear", the Receiver supplies a voltage of 24 V_{DC} on both outputs. The required load must therefore be connected between the output terminals and 0 V_{DC} (Figure 16).

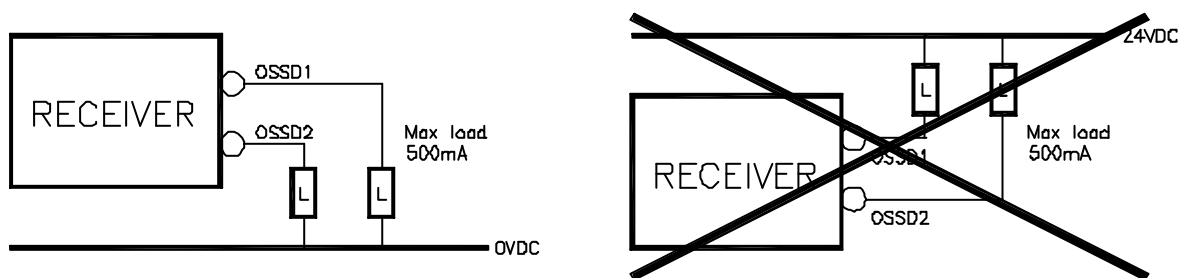

Figure 16

TECHNICAL SPECIFICATIONS

TECHNICAL SPECIFICATIONS OF SLC 210 / SLG 210 BARRIERS			
Protected height	mm	160 – 1810	
Resolutions	mm	20 –40– 90	
Working range	m	standard	0 – 6
		extension -H	1 - 16
Safety outputs		2 PNP – 500mA @24V _{DC}	
Response time	msec	(see tables)	
Internal test execution time	msec	500	
Power supply	V _{DC}	24 ± 20%	
Connections		M12 connector, 5-pole	
Max. conn. length	m	100	
Operating temp.	°C	0 - 55 °C	
Protection rating		IP 65	
Dimensions of section	mm	35 x 45	
Max. consumption	W	2 (Emitter)	3 (Receiver)

SLC 210-E/Rxxxx-20-12(-H) Resolution 20 mm	0160	0310	0460	0610	0760	0910	1060	1210	1360	1510	1660	1810
Number of beams	15	30	45	60	75	90	105	120	135	150	165	180
Response time msec	7	8,5	10,5	12,5	14,5	16,5	18	20	22	24	26	28
Overall barrier height mm	261	411	561	711	861	1011	1161	1311	1461	1611	1761	1911

SLC 210 E/Rxxxx-40-12(-H) Resolution 40 mm	0310	0460	0610	0760	0910	1060	1210	1360	1510	1660	1810
Number of beams	10	15	20	25	30	35	40	45	50	55	60
Response time msec	6	7	7,5	8	8,5	9,5	10	10,5	11	12	12,5
Overall barrier height mm	411	561	711	861	1011	1161	1311	1461	1611	1761	1911

SLC 210-E/Rxxxx-90-12(-H) Resolution 90 mm	0460	0610	0760	0910	1060	1210	1360	1510	1660	1810
Number of beams	7	9	11	13	15	17	19	21	23	25
Response time	6	6	6	6,5	7	7	7	7,5	8	8
Overall barrier height mm	561	711	861	1011	1161	1311	1461	1611	1761	1911

SLG 210-E/Rxxxx-xx-12(-H) Multibeam Models	0500-02	0800-03	0900-04
Number of beams	2	3	4
Distance between beams mm	500	400	300
Response time msec	6	6	6
Overall barrier height mm	711	1011	1111

DIMENSIONS (in mm)

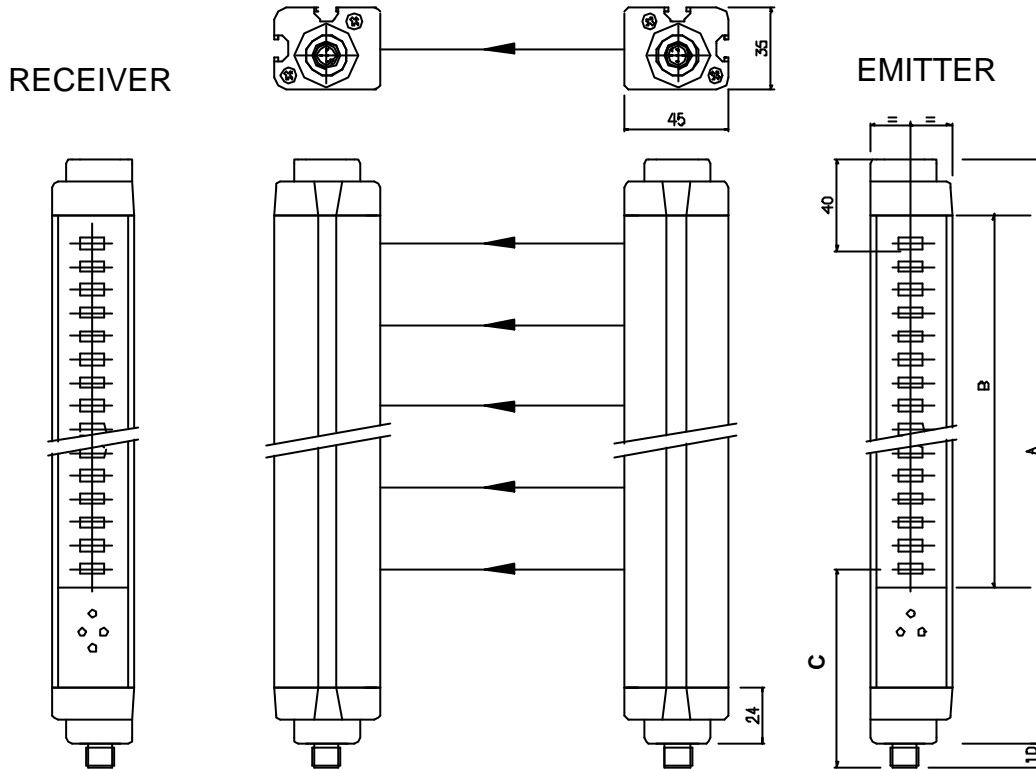

Figure 17
Emitter and Receiver

SLC 210E/Rxxxx-xx-12	0160	0310	0460	0610	0760	0910	1060	1210	1360	1510	1660	1810
A	251	401	551	701	851	1001	1151	1301	1451	1601	1751	1901
B (PROTECTED AREA)	160	310	460	610	760	910	1060	1210	1360	1510	1663	1810
C	85											
Mounting	2 mounting kits						3 mounting kits					

SLG 210E/Rxxxx-xx-12	0500-02	0800-03	0900-04
A	701	1001	1101
B	610	910	1010
C	135		

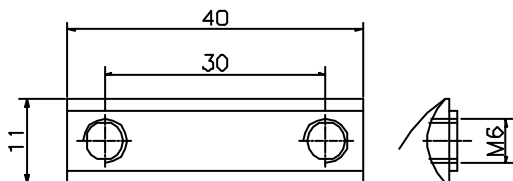
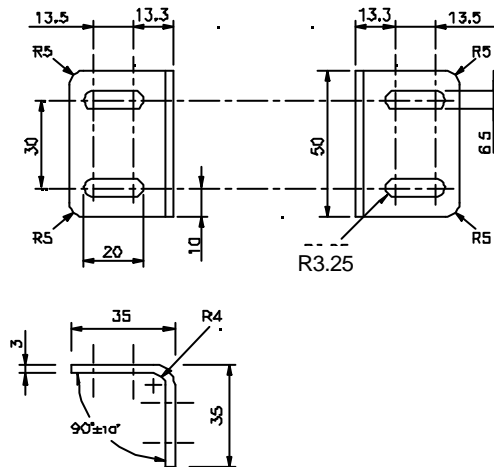

Figure 18
Mounting kit (inserts and fastening brackets) - included

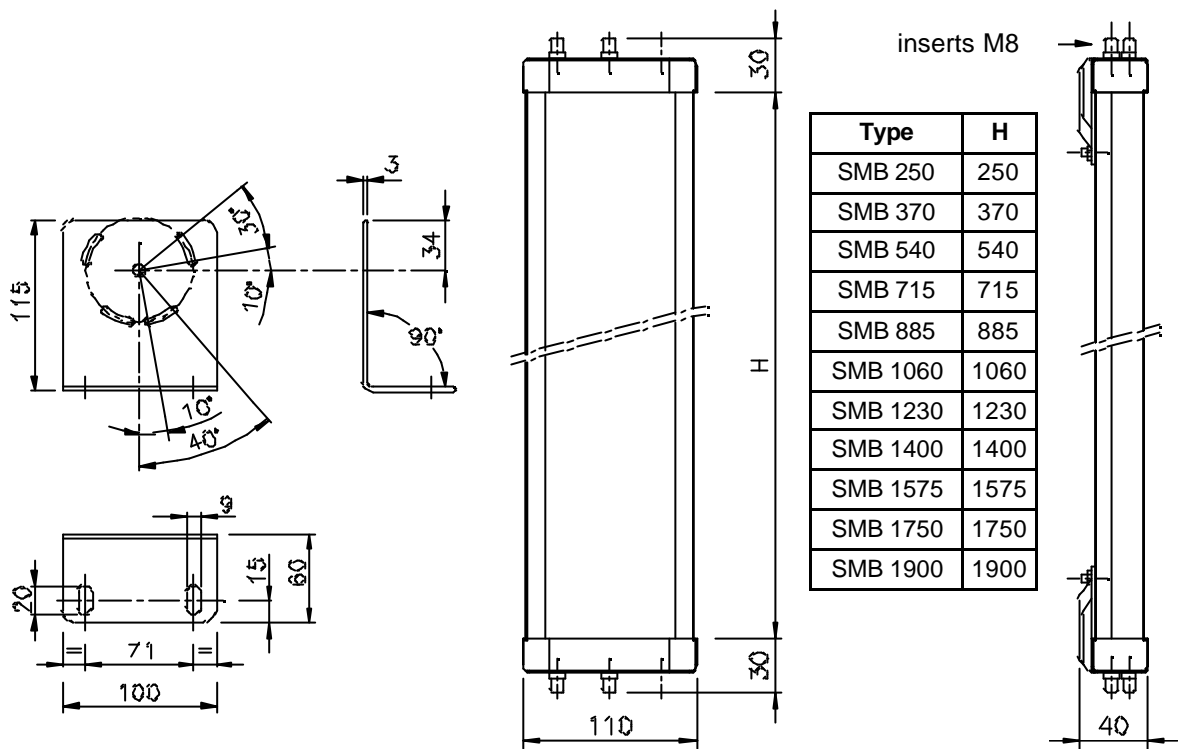

Figure 19
Fastening brackets for deviation mirrors

Figure 20
Deviation mirrors

CHECKS AND MAINTENANCE

Verification of barrier efficiency



Before each work shift or before switching on, check the correct operation of the photoelectric barrier.

Proceed as follows, intercepting the beams using the appropriate test object (available on request).



The correct test object must be used for testing, depending on the barrier resolution. Please see page 23 for the correct ordering code.

Refer to Figure 21:

- Introduce the test object into the protected area and move it slowly, starting from the top and moving down (or vice versa), first in the centre and then close to both Emitter and Receiver.
- MULTIBEAM MODELS:
Intercept each beam with an opaque object, first in the center of the detection zone and then close to the emitter and the receiver.
- Make sure that during each stage of the test object's movements the red LED on the Receiver is permanently on.

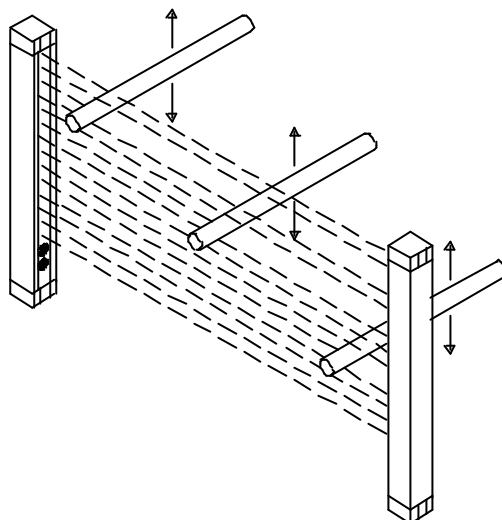

Figure 21

The SLC 210 / SLG 210 barrier does not require any specific maintenance operations; however, periodic cleaning of the front protective surfaces of the Emitter and Receiver optics is recommended.

Wipe with a clean, damp cloth; in particularly dusty environments, after cleaning the front surface, the use of an anti-static spray is recommended.

Never use abrasive or corrosive products, solvents or alcohol, which could damage parts. Do not use woollen cloths, that could electrify the front surface.

If the yellow weak signal LED on the Receiver switches on (LED 5 in Figure 15), check that:

- the front surfaces are clean;
- the Emitter and Receiver are aligned correctly.

If the LED stays on, contact the K.A. Schmersal GmbH.

TROUBLESHOOTING

The instructions provided by the LEDs of the Emitter and the Receiver enable the user to identify the cause of a number of system malfunctions.

Refer to figure 22 to verify the LEDs indications.

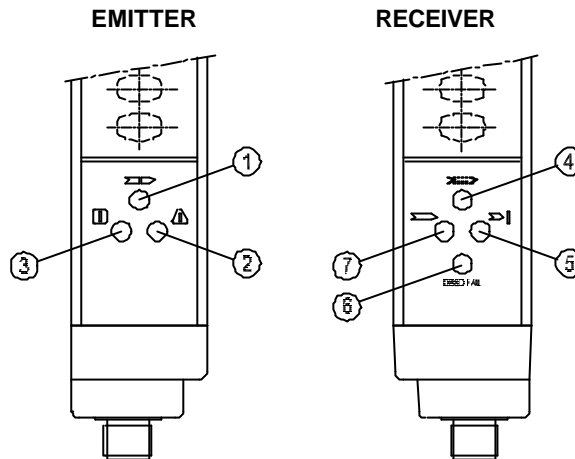

Figure 22

EMITTER

LED	COLOUR	STATUS	CONDITION
2	Red	On	Anomalous operation

RECEIVER

LED	COLOUR	STATUS	CONDITION
4	Yellow	On	Weak signal received
4	Yellow	Blinking	Detection of interfering light. The Receiver is able to receive the beams emitted by two different Emitters at the same time.
6	Red	On	Overcurrent on one or both outputs (OSSD) or probable short circuit between the two outputs.
6	Red	Blinking	Erroneous connection of semiconductor outputs (OSSD).
4	Yellow	Blinking	Internal failure detected
6	Red		

In any case, when faced with a system stoppage, switch the system off and then on again, to exclude any occasional electromagnetic disturbances. In case of continued malfunctioning:

- verify the integrity of electrical connections and check that these have been made correctly;
- check that the supply voltage levels comply with those specified in the technical data sheet;
- the barrier power supply should be kept separate from that of the other electric power equipment (electric motors, inverters, frequency converters) or other sources of disturbance.
- make sure that the Emitter and the Receiver are correctly aligned and that the front surfaces are perfectly clean.



If it is not possible to clearly identify the malfunction and to remedy it, stop the machine and contact the K.A. Schmersal GmbH.

If correct system operation cannot be restored after carrying out the above procedures, send the equipment to the K.A. Schmersal GmbH, complete with all parts, stating clearly:

- the product code number (the **P/N** field is shown on the product label)
- serial number (the **S/N** field is shown on the product label)
- date of purchase
- period of operation
- type of application
- fault.

SPARE PARTS

MODEL	ARTICLE	CODE
SCR 1R	SCR 1R Safety Relay	1666600420
KD M12-5-5m-S	Straight 5-pin M12 female connector, 5 m cable	1666655360
KD M12-5-15m-S	Straight 5-pin M12 female connector, 15 m cable	1666655380
SLC TR-14	14 mm diameter test rod	1666655410
SLC TR-30	30 mm diameter test rod	1666655430
SLC TR-50	50 mm diameter test rod	1666655450
BF LC-01	Set of 4 fastening brackets	1666655320
BF LC-02	Set of 6 fastening brackets	1666655330
VA 15-6	Set of 4 vibration absorbers for the fastening brackets.	1666655400
MS LC-01	Mounting set with 2 mounting kits	1666713100
MS LC-02	Mounting set with 3 mounting kits	1666713110

Specifications subject to change without warning. - No part of this manual may be reproduced without the prior consent of the K.A. Schmersal GmbH.