

INSTRUCTIONS POUR FONCTIONNEMENT ET MONTAGE

Safety switch with separate actuator AZ 15 ZVRK-M16

Table des matières

- 1 A propos de ce document
 - 1.1 Fonction
 - 1.2 Groupe cible pour le mode d'emploi : personnel qualifié et autorisé
 - 1.3 Symboles utilisés
 - 1.4 Définition de l'application
 - 1.5 Consignes de sécurité générales
- 2 Description du produit
 - 2.1 Exemple de commande
 - 2.2 Versions spéciales
 - 2.3 Destination et emploi
 - 2.4 Avertissement en cas de mauvaise utilisation
 - 2.5 Clause de non-responsabilité
 - 2.6 Données techniques
- 3 Montage
 - 3.1 Instructions de montage générales
 - 3.2 Montage de l'actionneur
 - 3.3 Dimensions
- 4 Raccordement électrique
 - 4.1 Notes générales pour le raccordement électrique
 - 4.2 Variantes de contact
- 5 Mise en service et maintenance
- 6 Démontage et mise au rebut
 - 6.1 Démontage
 - 6.2 Mise au rebut

1 A propos de ce document

1.1 Fonction

Le présent document fournit les informations nécessaires au montage, à la mise en service, au fonctionnement sûr ainsi qu'au démontage du dispositif de sécurité. Il est important de conserver le mode d'emploi joint à l'appareil à tout moment en condition lisible et accessible .

1.2 Groupe cible pour le mode d'emploi : personnel qualifié et autorisé

Toutes les manipulations sur l'appareil indiquées dans cette notice ne doivent être effectuées que par un personnel qualifié, spécialisé et autorisé par l'exploitant de l'installation.

Il est important de lire et de comprendre le mode d'emploi avant l'installation et la mise en service du composant. Vous devez également connaître les prescriptions en vigueur concernant la sécurité du travail et la prévention des accidents.

Pour le choix et le montage des composants ainsi que leur intégration dans le circuit de commande, le constructeur de machines doit observer les exigences des directives et des règlements en vigueur.

Les caractéristiques et recommandations figurant dans ce document sont exclusivement données à titre d'information et sans engagement contractuel de notre part.

1.3 Symboles utilisés



Informations, remarques: En suivant ce symbole, vous trouverez des informations complémentaires très utiles.



Attention: Le non-respect de cette recommandation peut entraîner des pannes ou des défauts de fonctionnement.

Avertissement: Le non-respect de cette instruction peut entraîner des blessures physiques et/ou des dommages machine.

1.4 Définition de l'application

La gamme de produits Schmersal n'est pas destinée aux particuliers

Les produits décrits dans ce mode d'emploi ont été développés pour réaliser des fonctions relatives à la sécurité comme partie intégrante d'une machine ou d'une installation. La responsabilité du fonctionnement correct de l'ensemble de l'installation incombe au fabricant de la machine.

Le dispositif de sécurité ne doit être utilisé que dans les dispositions suivantes ou pour les applications autorisées par le fabricant. Le champ d'application est décrit en détail dans le chapitre "Description du produit".

1.5 Consignes de sécurité générales

Les consignes de sécurité de ce mode d'emploi, les standards d'installation spécifiques du pays concerné ainsi que les dispositions de sécurité et les règles de prévention d'accidents sont à observer.



Pour toute autre information technique, veuillez vous référer aux catalogues Schmersal ou à notre catalogue en ligne products.schmersal.com.

2 Description du produit

2.1 Exemple de commande

Désignation produit: AZ 15 ZV(1)K-(2)-(3)
--

(1)	
Sans	Force d'éjection
R	Force de maintien 30 N

(2)	
M16	Entrée de câble M 16
M20	Entrée de câble M 20
ST	Connecteur M12, 4 pôles

(3)	
2254	Force de maintien 5 N
1762	Montage frontal
1637	contacts dorés

2.2 Versions spéciales

Pour les versions spéciales, qui ne sont pas reprises dans l'exemple de commande, les indications de ce mode d'emploi s'appliquent dans la mesure où ces modèles concordent avec les versions de série.

2.3 Destination et emploi

Les interrupteurs de sécurité avec actionneur séparé sont destinés aux protecteurs coulissants, pivotants ou amovibles qui doivent rester fermés afin de garantir la sécurité d'exploitation requise.

Les interrupteurs de sécurité sont utilisés pour les applications, dans lesquelles le mouvement dangereux n'a pas d'inertie d'arrêt après l'ouverture du protecteur.

L'ouverture du protecteur provoque l'ouverture forcée des contacts à manoeuvre d'ouverture positive et la fermeture des contacts à fermeture de l'interrupteur.



Les dispositifs de sécurité sont classifiés comme dispositifs de verrouillage de type 2 selon EN ISO 14119.



L'utilisateur doit évaluer et concevoir la chaîne de sécurité conformément aux normes applicables et en fonction du niveau de sécurité requis.



L'ensemble du système de commande, dans lequel le composant de sécurité est intégré, doit être validé selon les normes pertinentes.

2.4 Avertissement en cas de mauvaise utilisation



En cas d'emploi non-conforme, non-approprié ou en cas de manipulations frauduleuses, l'utilisation de l'appareil est susceptible d'entraîner des dommages pour l'homme ou des dégâts matériels. Aucun risque résiduel affectant la sécurité n'est connu, si les consignes de sécurité, les instructions de montage, de mise en service, de fonctionnement et d'entretien de ce mode d'emploi ont été respectés.

2.5 Clause de non-responsabilité

Nous déclinons toute responsabilité en cas de montage erroné ou de non-observation des instructions de ce mode d'emploi. Nous déclinons également les dommages en cas d'utilisation de pièces détachées ou d'accessoires non autorisés par le fabricant.

Pour des raisons de sécurité, il est strictement interdit de transformer ou modifier un dispositif de sécurité de sa propre initiative. Le fabricant ne peut être tenu responsable des dommages qui en découleraient.

2.6 Données techniques

Homologations - Règlementations

Certificates	cULus CCC
--------------	--------------

Caractéristiques globales

Standards	EN ISO 13849-1 EN ISO 14119 EN IEC 60947-5-1
Coding level according to EN ISO 14119	faible
Working principle	électromécanique
Housing material	Plastique, thermoplastique renforcé de fibres de verre, auto-extinguible
Gross weight	100 g

Données générales - Caractéristiques

Increased latching force	Oui
Suitable for elevators	Oui
Number of safety contacts	1
Number of cable glands	3

Classification

Vorschriften	EN ISO 13849-1
Mission time	20 Year(s)

Classification de sécurité - Sorties de sécurité

B _{10D} Normally-closed contact (NC)	2.000.000 Operations
---	----------------------

Données mécaniques

Mechanical life, minimum	1.000.000 Operations
Latching force	30 N
Positive break travel	8 mm
Positive break force per NC contact, minimum	10 N
Positive break force, minimum	10 N
Actuating speed, maximum	2 m/s
Mounting	Vis
Type of the fixing screws	2x M6

Données mécaniques - technique de connexion

Cable entry	3 x M16 x 1,5
Termination	Bornes à vis
Cable section, minimum	0,25 mm ²
Cable section, maximum	2,5 mm ²
Note	Toutes les indications relatives à la section du câble sont embouts compris.
Allowed type of cable	solid single-wire solid multi-wire flexible

Données mécaniques - Dimensions

Length of sensor	30 mm
Width of sensor	52 mm
Height of sensor	75 mm

Conditions ambiantes

Degree of protection	IP67
Ambient temperature	-30 ... +80 °C
Storage and transport temperature	-40 ... +85 °C
Permissible installation altitude above sea level, maximum	2.000 m

Conditions ambiantes - Valeur d'isolation

Rated insulation voltage U_i	500 V
Rated impulse withstand voltage U_{imp}	6 kV
Overvoltage category	III
Degree of pollution	3

Données électriques

Thermal test current	10 A
Required rated short-circuit current	1.000 A
Switching element	1 contacts NF
Switching principle	slow action, positive break NC contact
Maximale Schalthäufigkeit	4.000 /h
Material of the contacts, electrical	Argent

Données électriques - Contacts de sécurité

Voltage, Utilisation category AC-15	230 VAC
Current, Utilisation category AC-15	4 A
Voltage, Utilisation category DC-13	24 VDC
Current, Utilisation category DC-13	4 A

Remarques concernant la classification de sécurité:

De façon générale, utilisable jusqu'à cat. 1 / PL c.

En cas d'utilisation de 2 canaux et exclusion de défauts mécaniques (si une exclusion de défauts pour la mécanique à 1 canal est autorisée) et module de sécurité approprié, jusqu'à cat. 3 / PL d.

$$MTTF_D = \frac{B_{10D}}{0,1 \times n_{op}} \quad n_{op} = \frac{d_{op} \times h_{op} \times 3600 \text{ s/h}}{t_{cycle}}$$

(Les valeurs indiquées peuvent varier en fonction des paramètres spécifiques de l'application h_{op} , d_{op} et t_{cycle} ainsi que de la charge.)

Lorsque plusieurs composants de sécurité sont connectés en série, le Niveau de Performance PL selon EN ISO 13849-1 peut être dégradé dans certaines conditions, parce que la qualité du diagnostic des défauts s'est réduite.

3 Montage

3.1 Instructions de montage générales



Veillez observer les remarques des normes ISO 12100, ISO 14119 et ISO 14120.

Les dimensions de montage sont indiquées à l'arrière du boîtier. Le boîtier de l'interrupteur ne doit pas être utilisé comme butée mécanique.

La position de montage est indifférente. Elle doit toutefois être choisie de manière à ce que la pénétration de saletés et d'encrassements dans l'ouverture utilisée soit empêchée. Après le montage, les ouvertures non-utilisées doivent être obturées au moyen des obturateurs (pour AZ 15/16-1476-1, disponibles comme accessoires).

3.2 Montage de l'actionneur

Voir mode d'emploi de l'actionneur.



L'actionneur doit être fixé sur le protecteur de manière indémontable (vis indémontables, collage, perçage des têtes de vis, goupillage) et est à protéger contre le décalage.

Rayons d'actionnement [mm]	 par le côté étroit de l'actionneur		 par le côté large de l'actionneur	
	R_{min}	d	R_{min}	d
	AZ 15/16-B2	-	-	45
AZ 15/16-B2-1747	-	-	45	11
AZ 15/16-B3	32	11	-	-
AZ 15/16-B3-1747	32	11	-	-
AZ 15/16-B6	25	11	38	11

3.3 Dimensions

Toutes les dimensions sont indiquées en mm.

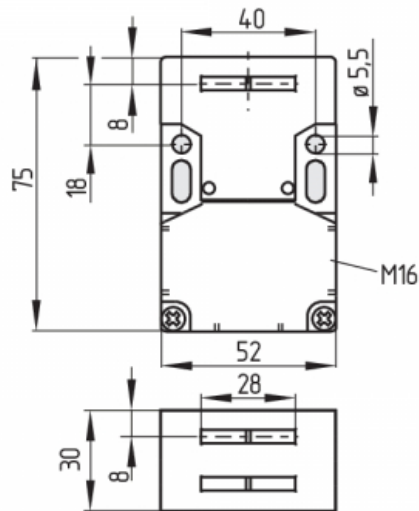

Montage frontal

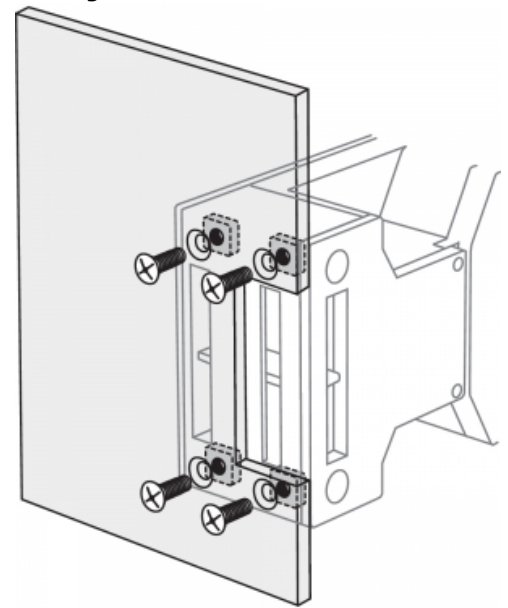

4 Raccordement électrique

4.1 Notes générales pour le raccordement électrique



Le raccordement électrique est à effectuer uniquement hors tension par du personnel compétent et qualifié.

Les désignations des contacts sont indiquées dans le compartiment de câblage à l'intérieur de l'interrupteur. Pour l'entrée de câble, des presse-étoupe avec un indice de protection approprié sont à utiliser.

Longueur x du fil dénudé: 6 mm

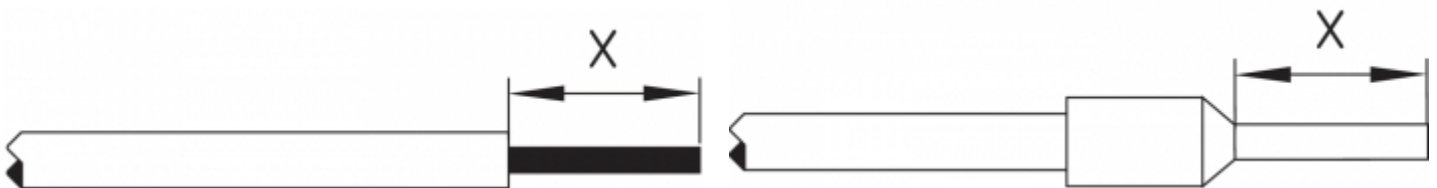

Après le raccordement, le compartiment de câblage doit être nettoyé. L'interrupteur de sécurité possède une double isolation. La connexion à la terre n'est donc pas autorisée.

4.2 Variantes de contact

Représentation des contacts, protecteur fermé Tous les contacts NF à manœuvre positive d'ouverture .

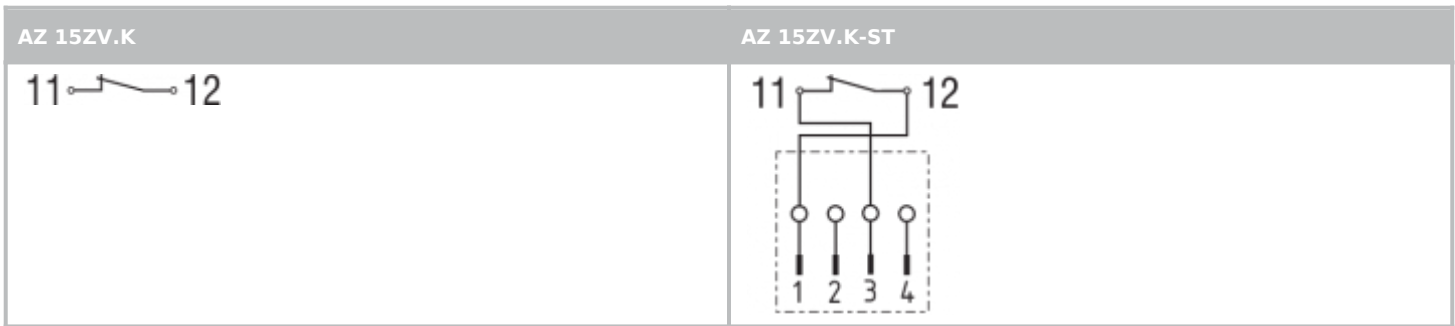

Légende	
	Contact NF à manoeuvre positive d'ouverture
	Contact normalement fermé

5 Mise en service et maintenance

La fonction de sécurité du dispositif de sécurité doit être testée. En cas d'une installation correcte et d'une utilisation appropriée, le dispositif de sécurité ne nécessite aucun entretien. Nous recommandons une inspection visuelle et une vérification régulière selon les étapes suivantes:

1. Vérification du libre mouvement de l'organe de commande
2. Vérifier les entrées de câbles et les bornes de raccordement
3. Vérification si le boîtier de l'interrupteur est endommagé
4. Enlèvement de la poussière et des encrassements



Dans toutes les phases de vie opérationnelles du dispositif de sécurité, des mesures antifraudes constructives et organisationnelles appropriées doivent être prises pour empêcher toute fraude du protecteur, par exemple au moyen d'un actionneur de remplacement.



Remplacer les appareils endommagés ou défectueux.

6 Démontage et mise au rebut

6.1 Démontage

Le dispositif de sécurité doit être démonté uniquement hors tension.

6.2 Mise au rebut



Le dispositif de sécurité doit être mis au rebut conformément aux prescriptions et législations nationales.