

INSTRUCTIONS POUR FONCTIONNEMENT ET MONTAGE

Dispositif d'interverrouillage AZM 161SK-12/12RKED -110/230

Table of Contents

- 1 Zu diesem Dokument
 - 1.1 Funktion
 - 1.2 Zielgruppe der Betriebsanleitung: autorisiertes Fachpersonal
 - 1.3 Verwendete Symbolik
 - 1.4 Bestimmungsgemäßer Gebrauch
 - 1.5 Allgemeine Sicherheitshinweise
- 2 Produktbeschreibung
 - 2.1 Typenschlüssel
 - 2.2 Sonderausführungen
 - 2.3 Bestimmung und Gebrauch
 - 2.4 Warnung vor Fehlgebrauch
 - 2.5 Haftungsausschluss
 - 2.6 Technische Daten
- 3 Montage
 - 3.1 Allgemeine Montagehinweise
 - 3.2 Abmessungen
 - 3.3 Hilfsentriegelung
 - 3.4 Notentsperrung (Bestellindex -N)
 - 3.5 Fluchtentriegelung
- 4 Elektrischer Anschluss
 - 4.1 Allgemeine Hinweise zum elektrischen Anschluss
 - 4.2 Kontaktvarianten
- 5 Inbetriebnahme und Wartung
- 6 Demontage und Entsorgung
 - 6.1 Demontage
 - 6.2 Entsorgung

1 Zu diesem Dokument

1.1 Funktion

Das vorliegende Dokument liefert die erforderlichen Informationen für die Montage, die Inbetriebnahme, den sicheren Betrieb sowie die Demontage des Sicherheitsschaltgerätes. Die dem Gerät beiliegende Betriebsanleitung ist stets in einem leserlichen Zustand und zugänglich aufzubewahren.

1.2 Zielgruppe der Betriebsanleitung: autorisiertes Fachpersonal

Sämtliche in der Betriebsanleitung beschriebenen Handhabungen dürfen nur durch ausgebildetes und vom Anlagenbetreiber autorisiertes Fachpersonal durchgeführt werden.

Installieren und nehmen Sie das Gerät nur dann in Betrieb, wenn Sie die Betriebsanleitung gelesen und verstanden haben und Sie mit den geltenden Vorschriften über Arbeitssicherheit und Unfallverhütung vertraut sind.

Auswahl und Einbau der Geräte sowie ihre steuerungstechnische Einbindung sind an eine qualifizierte Kenntnis der einschlägigen Gesetze und normativen Anforderungen durch den Maschinenhersteller geknüpft.

Alle Angaben ohne Gewähr. Änderungen, die dem technischen Fortschritt dienen, vorbehalten.

1.3 Verwendete Symbolik



Information, Tipp, Hinweis: Dieses Symbol kennzeichnet hilfreiche Zusatzinformationen.



Vorsicht: Bei Nichtbeachten dieses Warnhinweises können Störungen oder Fehlfunktionen die Folge sein.

Warnung: Bei Nichtbeachten dieses Warnhinweises kann ein Personenschaden und/oder ein Schaden an der Maschine die Folge sein.

1.4 Bestimmungsgemäßer Gebrauch

Das Schmersal-Lieferprogramm ist nicht für den privaten Verbraucher bestimmt.

Die hier beschriebenen Produkte wurden entwickelt, um als Teil einer Gesamtanlage oder Maschine sicherheitsgerichtete Funktionen zu übernehmen. Es liegt im Verantwortungsbereich des Herstellers einer Anlage oder Maschine, die korrekte Gesamtfunktion sicherzustellen.

Das Sicherheitsschaltgerät darf ausschließlich entsprechend der folgenden Ausführungen oder für durch den Hersteller zugelassene Anwendungen eingesetzt werden. Detaillierte Angaben zum Einsatzbereich finden Sie im Kapitel „Produktbeschreibung“.

1.5 Allgemeine Sicherheitshinweise

Die Sicherheitshinweise der Betriebsanleitung sowie landesspezifische Installations-, Sicherheits- und Unfallverhütungsvorschriften sind zu beachten.



Weitere technische Informationen entnehmen Sie bitte den Schmersal Katalogen bzw. dem Online-Katalog im Internet unter products.schmersal.com.

2 Produktbeschreibung

2.1 Typenschlüssel

Produkt-Typbezeichnung: AZM161 (1)-(2)(3)K(4)-(5)/(6)-(7)(8)	
(1)	
SK	Schraubklemmen
CC	Federkraftklemmen
ST	Einbaustecker M12
(2)	
11/03	Magnet: 1 Schließer (NO), 1 Öffner (NC) / Betätiger: 3 Öffner (NC) mit Einbaustecker
12/03	Magnet: 1 Schließer (NO), 2 Öffner (NC) / Betätiger: 3 Öffner (NC)
12/11	Magnet: 1 Schließer (NO), 2 Öffner (NC) / Betätiger: 1 Schließer (NO), 1 Öffner (NC) mit Einbaustecker
11/12	Magnet: 1 Schließer (NO), 1 Öffner (NC) / Betätiger: 1 Schließer (NO), 2 Öffner (NC) mit Einbaustecker
12/12	Magnet: 1 Schließer (NO), 2 Öffner (NC) / Betätiger: 1 Schließer (NO), 2 Öffner (NC)
(3)	
<i>ohne</i>	Rastkraft 5 N
R	Rastkraft 30 N
(4)	
<i>ohne</i>	Ruhestromprinzip
A	Arbeitsstromprinzip
(5)	
<i>ohne</i>	Hilfsentriegelung seitlich
ED	Hilfsentriegelung deckelseitig
EU	Hilfsentriegelung rückseitig
(6)	
T	Fluchtentriegelung seitlich

TD	Fluchtentriegelung deckelseitig
TU	Fluchtentriegelung rückseitig
N	Notentsperrung

(7)	
024	Us: 24 VAC/DC
110/230	Us: 110/230 VAC

(8)	
<i>ohne</i>	ohne LED
G	mit LED (Nur für Us: 24 VAC/DC)

2.2 Sonderausführungen

Für Sonderausführungen, die nicht im Typenschlüssel aufgeführt sind, gelten die vor- und nachgenannten Angaben sinngemäß, soweit diese mit der serienmäßigen Ausführung übereinstimmen.

2.3 Bestimmung und Gebrauch

Die Sicherheitszuhaltung stellt im Zusammenwirken mit dem steuerungstechnischen Teil der Maschine sicher, dass eine bewegliche Schutzeinrichtung nicht geöffnet werden kann, bis gefahrbringende Zustände beendet sind.



Sicherheitszuhaltungen mit Arbeitsstromprinzip dürfen nur in Sonderfällen nach einer strengen Bewertung des Unfallrisikos verwendet werden, da bei Spannungsausfall bzw. Betätigen des Hauptschalters die Schutzeinrichtung unmittelbar geöffnet werden kann.



Die Sicherheitsschaltgeräte sind gemäß EN ISO 14119 als Bauart 2-Verriegelungseinrichtungen klassifiziert.



Die Bewertung und Auslegung der Sicherheitskette ist vom Anwender entsprechend der relevanten Normen und Vorschriften und in Abhängigkeit vom erforderlichen Sicherheitsniveau vorzunehmen.



Das Gesamtkonzept der Steuerung, in welche die Sicherheitskomponente eingebunden wird, ist nach den relevanten Normen zu validieren.

2.4 Warnung vor Fehlgebrauch



Bei nicht sachgerechter oder nicht bestimmungsgemäßer Verwendung oder Manipulationen können durch den Einsatz des Sicherheitsschaltgerätes Gefahren für Personen oder Schäden an Maschinen- bzw. Anlagenteilen nicht ausgeschlossen werden. Restrisiken sind bei Beachtung der Hinweise zur Sicherheit sowie der Anweisungen bezüglich Montage, Inbetriebnahme, Betrieb und Wartung nicht bekannt.

2.5 Haftungsausschluss

Für Schäden und Betriebsstörungen, die durch Montagefehler oder Nichtbeachtung der Betriebsanleitung entstehen, wird keine Haftung übernommen. Für Schäden, die aus der Verwendung von nicht durch den Hersteller freigegebenen Ersatz- oder Zubehöerteilen resultieren, ist jede weitere Haftung des Herstellers ausgeschlossen.

Jegliche eigenmächtige Reparaturen, Umbauten und Veränderungen sind aus Sicherheitsgründen nicht gestattet und schließen eine Haftung des Herstellers für daraus resultierende Schäden aus.

2.6 Technische Daten

Homologations - Règlementations

Certificates	IFA cULus CCC UKCA
--------------	-----------------------------

Caractéristiques globales

Standards	EN ISO 13849-1 EN ISO 14119 EN IEC 60947-5-1
Coding level according to EN ISO 14119	faible
Working principle	électromécanique
Housing material	Plastique, thermoplastique renforcé de fibres de verre, auto-extinguible
Gross weight	485 g

Données générales - Caractéristiques

Power to unlock	Oui
Manual release	Oui
Number of actuating directions	3
Number of auxiliary contacts	2
Number of safety contacts	4

Classification

Standards	EN ISO 13849-1
Performance Level, up to	c
Category	1
B _{10D} Normally-closed contact (NC)	2 000 000 Operations
Note	Electrical life on request.
B _{10D} Normally-open contact (NO)	1 000 000 Operations
Note	at 10% I _e and ohmic load
Mission time	20 Year(s)

Classification de sécurité - Exclusion de défauts

Please note:	Utilisable si l'exclusion d'une défaillance dangereuse de la mécanique à 1 canal est autorisée et si une protection antifraude suffisante est garantie.
Performance Level, up to	d
Category	3
Note	for 2-channel use and with suitable logic unit.
Mission time	20 Year(s)

Classification de sécurité - Fonction de verrouillage

Performance Level, up to	e
Note (Performance Level)	Information for the safety classification of the guard locking function is documented in the "Operating instructions" or in the "Operation and mounting" instructions.

Données mécaniques

Mechanical life, minimum	1 000 000 Operations
Actuating play in direction of actuation	5,5 mm
Holding force F _{Zh} in accordance with EN ISO 14119	2 000 N
Holding force F _{max} ' maximum	2 600 N
Latching force	30 N
Positive break travel	10 mm
Positive break force per NC contact, minimum	10 N
Positive break force, minimum	20 N
Actuating speed, maximum	2 m/s

Mounting	Vis
Type of the fixing screws	3x M5
Type of the screw head	Flat head screw
Tightening torque of the fastening screws for the housing cover	0,6 Nm
Note	The tightening sequence of the cover screws must be observed. This can be found in the attached drawing in the "Pictures" tab.

Données mécaniques - technique de connexion

Cable entry	4 x M16 x 1,5
Termination	Bornes à vis
Cable section, minimum	0,25 mm ²
Cable section, maximum	1,5 mm ²
Note	Toutes les indications relatives à la section du câble sont embouts compris.
Allowed type of cable	solid single-wire solid multi-wire flexible

Données mécaniques - Dimensions

Length of sensor	30 mm
Width of sensor	130 mm
Height of sensor	90 mm

Conditions ambiantes

Degree of protection	IP67
Ambient temperature	-30 ... +60 °C
Storage and transport temperature	-30 ... +85 °C
Note (Relative humidity)	sans condensation non givrant
Protection class	II
Permissible installation altitude above sea level, maximum	2 000 m

Conditions ambiantes - Valeur d'isolation

Rated insulation voltage U_i	250 VAC
Rated impulse withstand voltage U_{imp}	4 kV

Données électriques

Thermal test current	6 A
Rated control voltage	110 VAC 230 VAC
Required rated short-circuit current	1 000 A
Electrical power consumption, maximum	10 W
Switching element	Contact NO, contact NF
Switching principle	slow action, positive break NC contact
Maximum switching frequency	1 000 /h
Material of the contacts, electrical	Argent

Données électriques - Commande de l'électroaimant IN

Magnet switch-on time	100 %
Test pulse duration, maximum	5 ms
Test pulse interval, minimum	50 ms

Données électriques - Contacts de sécurité

Voltage, Utilisation category AC-15	230 VAC
Current, Utilisation category AC-15	4 A
Voltage, Utilisation category DC-13	24 VDC
Current, Utilisation category DC-13	2,5 A

Données électriques - Contacts auxiliaires

Voltage, Utilisation category AC-15	230 VAC
Current, Utilisation category AC-15	4 A
Voltage, Utilisation category DC-13	24 VDC
Current, Utilisation category DC-13	2,5 A

Données diverses

Note (applications)	protecteur coulissant protecteur amovible protecteur pivotant
---------------------	---

Hinweise zur Sicherheitsbetrachtung

- Sicherheitsbetrachtung der Verriegelungsfunktion

Grundsätzlich einsetzbar bis Kat. 1 / PL c.

Bei 2-kanaligem Einsatz mit Fehlerausschluss Mechanik (wenn ein Fehlerausschluss für die 1-kanalige Mechanik zulässig ist) und geeigneter Logik einsetzbar bis Kat. 3 / PL d.

$$MTTF_D = \frac{B_{10D}}{0,1 \times n_{op}} \quad n_{op} = \frac{d_{op} \times h_{op} \times 3600 \text{ s/h}}{t_{cycle}}$$

(Ermittelte Werte können in Abhängigkeit der applikationsspezifischen Parameter h_{op} , d_{op} und t_{cycle} sowie der Last variieren.)

Werden mehrere Sicherheitskomponenten in Reihe geschaltet, wird der Performance Level nach EN ISO 13849-1 aufgrund verringerter Fehlererkennung unter Umständen reduziert.

- Sicherheitsbetrachtung der Zuhaltfunktion

Bei Einsatz des Gerätes als Zuhaltung für den Personenschutz ist eine Sicherheitsbetrachtung der Zuhaltfunktion erforderlich. Bei der Sicherheitsbetrachtung der Zuhaltfunktion ist zwischen der Überwachung der Verriegelungsfunktion und der Ansteuerung der Entsperrfunktion zu unterscheiden. Die nachfolgende Sicherheitsbetrachtung der Entsperrfunktion basiert auf der Anwendung des Prinzips der sicheren Energietrennung für die Magnetversorgung.



Die Sicherheitsbetrachtung der Entsperrfunktion ist nur gültig für Geräte mit überwachter Zuhaltfunktion in Ruhestromausführung (vgl. Typenschlüssel).

Durch eine sichere Energietrennung von außen kann ein Fehlerausschluss für die Sperrvorrichtung der Zuhaltung angenommen werden. Die Sperrvorrichtung der Zuhaltung trägt in diesem Fall nicht zur Ausfallwahrscheinlichkeit der Entsperrfunktion bei. Das Sicherheitsniveau der Entsperrfunktion wird somit ausschließlich von der externen sicheren Energieabschaltung bestimmt.

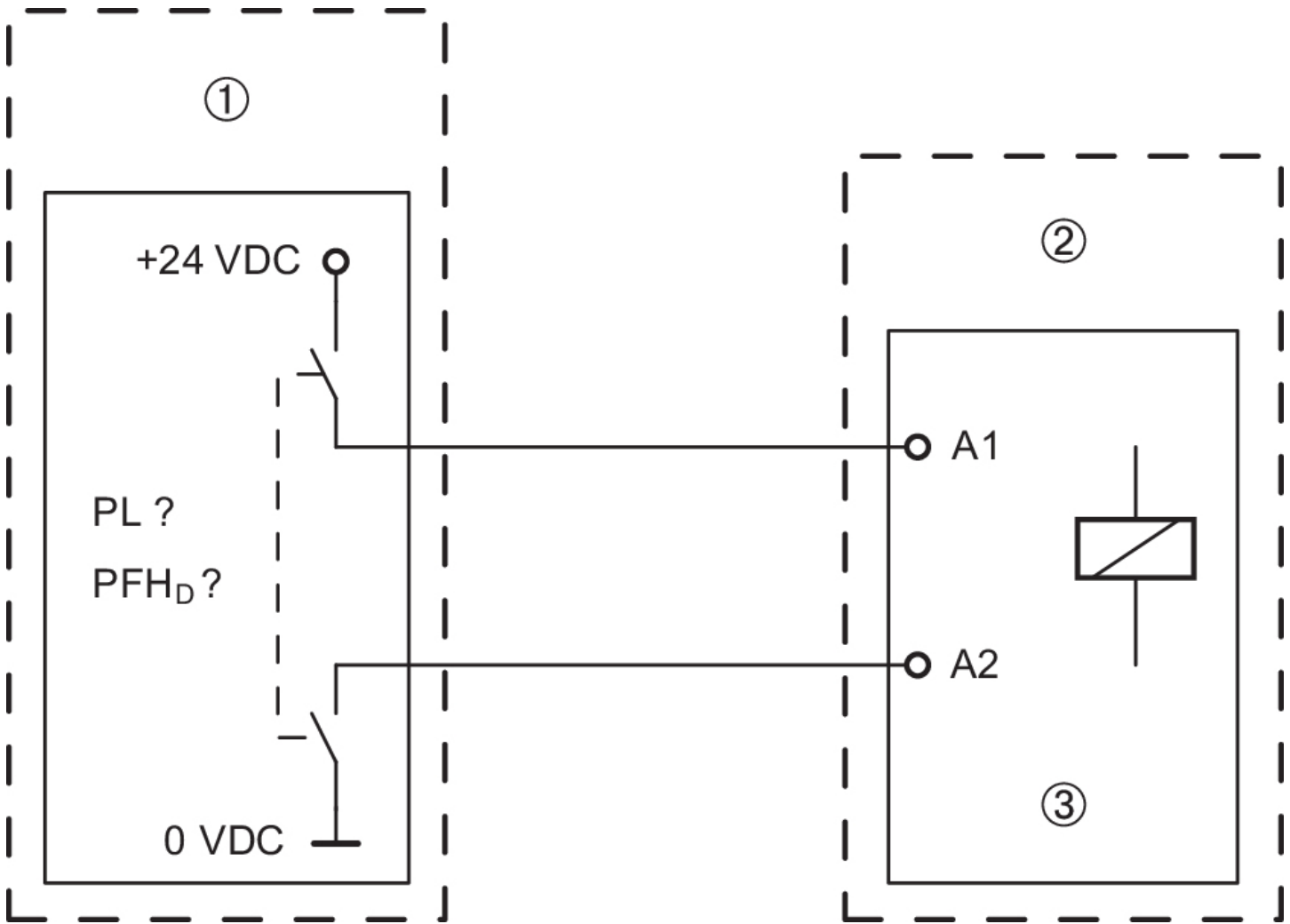

Legende	
①	Sichere Energieabschaltung
②	Sicherheitszuhaltung
③	Zuhaltfunktion



Die Fehlerausschlüsse für die Leitungsverlegung sind zu beachten.



Falls in einer Anwendung die Ruhestromausführung einer Sicherheitszuhaltung nicht eingesetzt werden kann, so ist für diesen Ausnahmefall eine Zuhaltung mit Arbeitsstromprinzip verwendbar, wenn zusätzliche Sicherheitsmaßnahmen realisiert werden, welche ein gleichwertiges Sicherheitsniveau herstellen.

UL-Hinweis



Verwenden Sie Verbindungsstücke des Typs 4X (für Innenräume) und 12. Anzugsdrehmoment: 4,4 lb in.

3 Montage

3.1 Allgemeine Montagehinweise



Bitte beachten Sie die Hinweise der Normen EN ISO 12100, EN ISO 14119 und EN ISO 14120.

Zur Befestigung des Gehäuses sind drei Bohrungen vorhanden. Die Sicherheitszuhaltung ist schutzisoliert. Ein Schutzleiter ist nicht zulässig. Die Sicherheitszuhaltung darf nicht als Anschlag benutzt werden. Die Gebrauchslage ist beliebig. Sie sollte jedoch so gewählt werden, dass kein grober Schmutz in die benutzten Öffnungen eindringen kann. Nicht benutzte Betätigeröffnungen sind mit Schlitzverschlüssen zu verschließen.



Der Betätiger ist durch geeignete Maßnahmen (Verwendung von Einwegschrauben, Verkleben, Aufbohren von Schraubenköpfen, Verstiften) an der Schutzeinrichtung unlösbar zu befestigen und gegen Verschieben zu sichern.

3.2 Abmessungen

Alle Maße in mm.



3.3 Hilfsentriegelung

(bei Einrichtung, Wartung usw.)

Die manuelle Entriegelung erfolgt durch Drehen des Dreikants um 180° (Dreikantschlüssel M5 als Zubehör erhältlich), wodurch der Riegelbolzen in Entriegelungsstellung gezogen wird. Hierbei ist darauf zu achten, dass durch äußere Einwirkung über den Betätiger kein Verklemmen stattfindet. Erst nach Zurückdrehen des Dreikants in die Ausgangslage ist die normale Riegelfunktion wieder gegeben. Die Hilfsentriegelung ist nach erfolgter Inbetriebnahme durch Aufdrücken der beigefügten Kunststoffkappe zu sichern.

Hilfsentriegelung seitlich	Hilfsentriegelung deckelseitig bzw. rückseitig (Bestellindex - ED/-EU)
----------------------------	--



Der Dreikantschlüssel TK-M5 (101100887) ist als Zubehör erhältlich.

3.4 Notentsperrung (Bestellindex -N)

(Anbau und Betätigung nur außerhalb des Gefahrenbereiches)



Die Notentsperrung ist nur im Notfall zu benutzen. Die Sicherheitszuhalterung ist so anzubringen und/oder zu schützen, dass ein unbeabsichtigtes Öffnen der Zuhalterung durch die Notentsperrung vermieden wird. Die Notentsperrung muss deutlich mit dem Hinweis gekennzeichnet sein, dass sie nur im Notfall zu benutzen ist. Hierfür kann der beiliegende Aufkleber verwendet werden.

Zur Notentsperrung orangefarbenen Hebel in Pfeilrichtung bis zum Anschlag drehen. Die Schutzeinrichtung lässt sich in dieser Stellung öffnen. Der Hebel ist verrastet und lässt sich nicht zurückdrehen. Zum Aufheben der Sperrstellung muss die zentrale Befestigungsschraube nur soweit herausgedreht werden, bis die Sperrstellung aufgehoben ist. Hebel in die Ausgangsdrehung zurückdrehen und Schraube wieder fest anziehen.



3.5 Fluchentriegelung

(Anbau und Betätigung nur innerhalb des Gefahrenbereiches)

Zur Fluchentriegelung der Ausführung T den orangefarbenen Hebel in Pfeilrichtung bis zum Anschlag drehen. Die Fluchentriegelung für die Ausführungen TD und TU erfolgt durch Drücken des roten Schlagtasters. Die Schutzeinrichtung lässt sich in dieser Stellung öffnen. Die Sperrstellung wird durch Zurückdrehen des Hebels in Gegenrichtung bzw. Zurückziehen des Schlagtasters aufgehoben. In entriegelter Stellung ist die Schutzeinrichtung gegen ungewolltes Schließen gesichert.

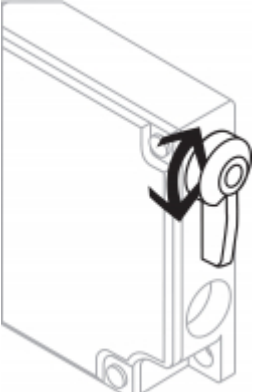
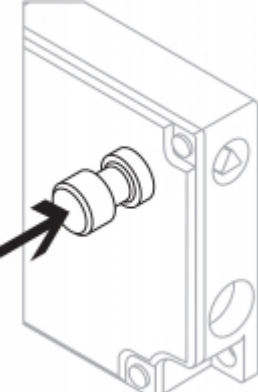
Fluchtentriegelung seitlich (Bestellindex -T)	Fluchtentriegelung deckelseitig bzw. rückseitig (Bestellindex -TD/-TU)
 <p>A technical drawing showing a side view of a door release mechanism. A curved handle is attached to a vertical rod that passes through the door. A double-headed arrow indicates the handle's range of motion.</p>	 <p>A technical drawing showing a side view of a door release mechanism. A cylindrical handle is mounted on the top or bottom edge of the door. An arrow points to the handle, indicating its operation.</p>

4 Elektrischer Anschluss

4.1 Allgemeine Hinweise zum elektrischen Anschluss



Der elektrische Anschluss darf nur im spannungslosen Zustand und von autorisiertem Fachpersonal durchgeführt werden.



Wenn durch die Risikoanalyse eine sicher überwachte Zuhaltung gefordert ist, sind die mit dem Symbol  gekennzeichneten Kontakte in den Sicherheitskreis einzubinden.

Zur Leitungseinführung sind geeignete Kabelverschraubungen mit entsprechender Schutzart zu verwenden. Durch Eindrehen der Kabelverschraubung die Wände der Bohrungen herausbrechen. Alle Kunststoffreste sind aus dem Gerät zu entfernen.

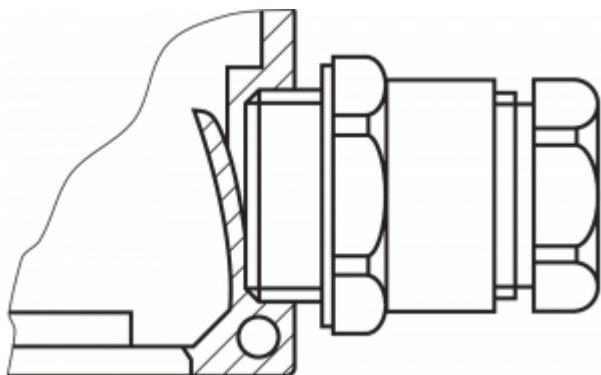

Das Durchstoßen der Bohrungswände mit Hilfswerkzeugen (bspw. Schraubendreher) kann zu Beschädigungen führen.

Absetzlänge x des Leiters:

- an Federkraftklemmen (CC) des Typs s oder f: 5 ... 6 mm
- an Schraubklemmen (SK): 7 mm



Nach erfolgtem Anschluss ist der Schalterinnenraum von Schmutzteilen zu säubern und der Gehäusedeckel wieder zu montieren. Der Anzugsdrehmoment der Deckelschrauben beträgt 0,6 Nm. Die Anzugsreihenfolge der Schrauben ist folgender Abbildung zu entnehmen.

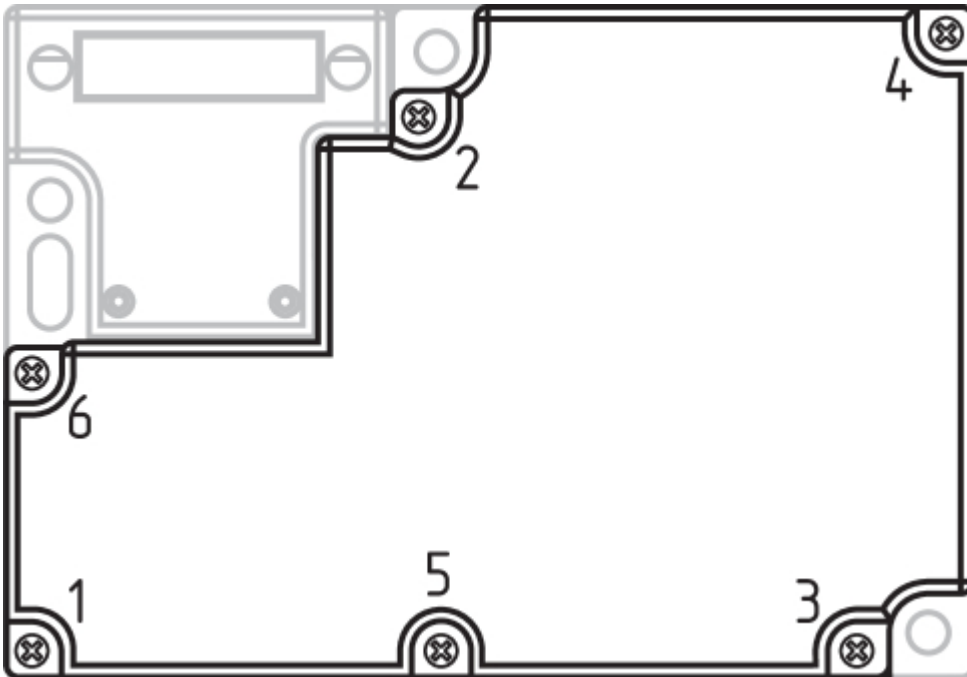

4.2 Kontaktvarianten

Darstellung der Kontakte im stromlosen Zustand und bei eingeschobenen Betätiger.

Ruhestromprinzip	Arbeitsstromprinzip
AZM 161SK-12/12... und AZM 161CC-12/12...	
<p>13 14 21 22 41 42 51 52 63 64 71 72 A1 A2</p>	<p>13 14 21 22 41 42 51 52 63 64 71 72 A1 A2</p>
AZM 161SK-12/03... und AZM 161CC-12/03...	
<p>11 12 21 22 41 42 51 52 63 64 71 72 A1 A2</p>	<p>11 12 21 22 41 42 51 52 63 64 71 72 A1 A2</p>
Legende	
	Zwangsoffnender Öffnerkontakt
	Überwachung der Zuhaltung gem. EN ISO 14119
	Betätigt
	Unbetätigt
AZM 161ST-../.. mit Stecker AZM 161ST-12/11...	AZM 161ST-11/12...



AZM 161...-G mit LED

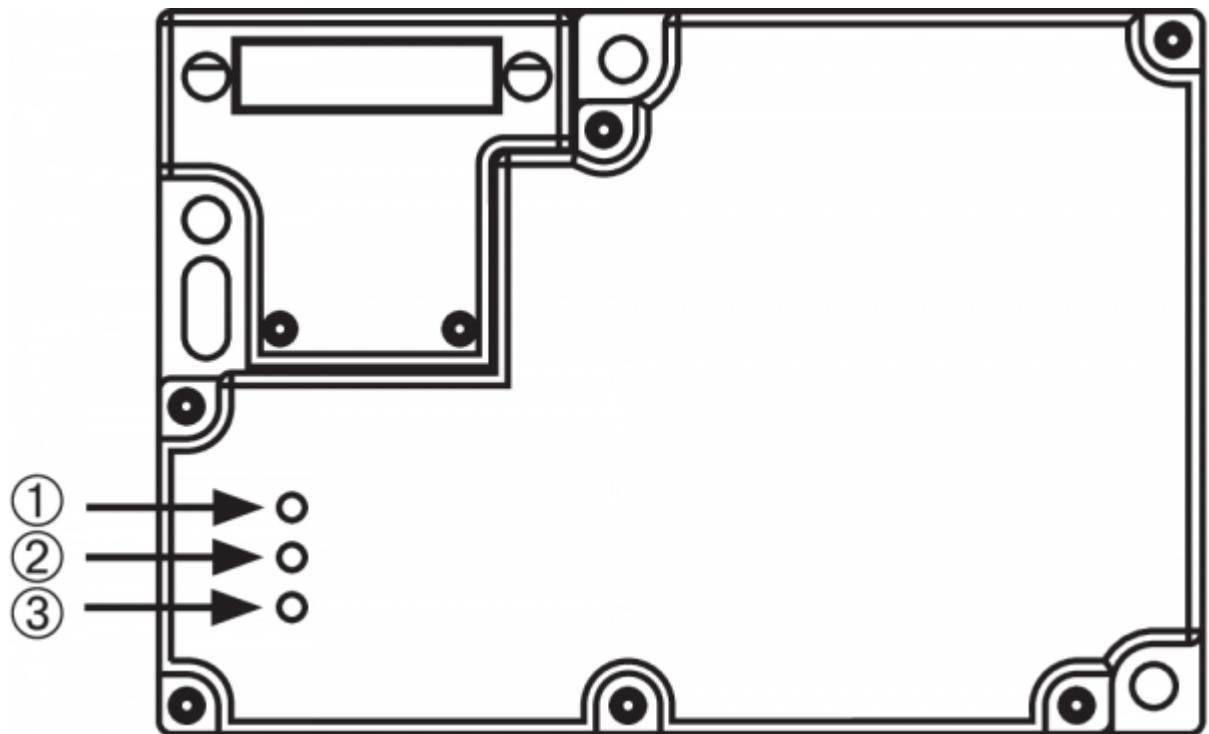

Kontaktsatz 12/12 G (mit LED)

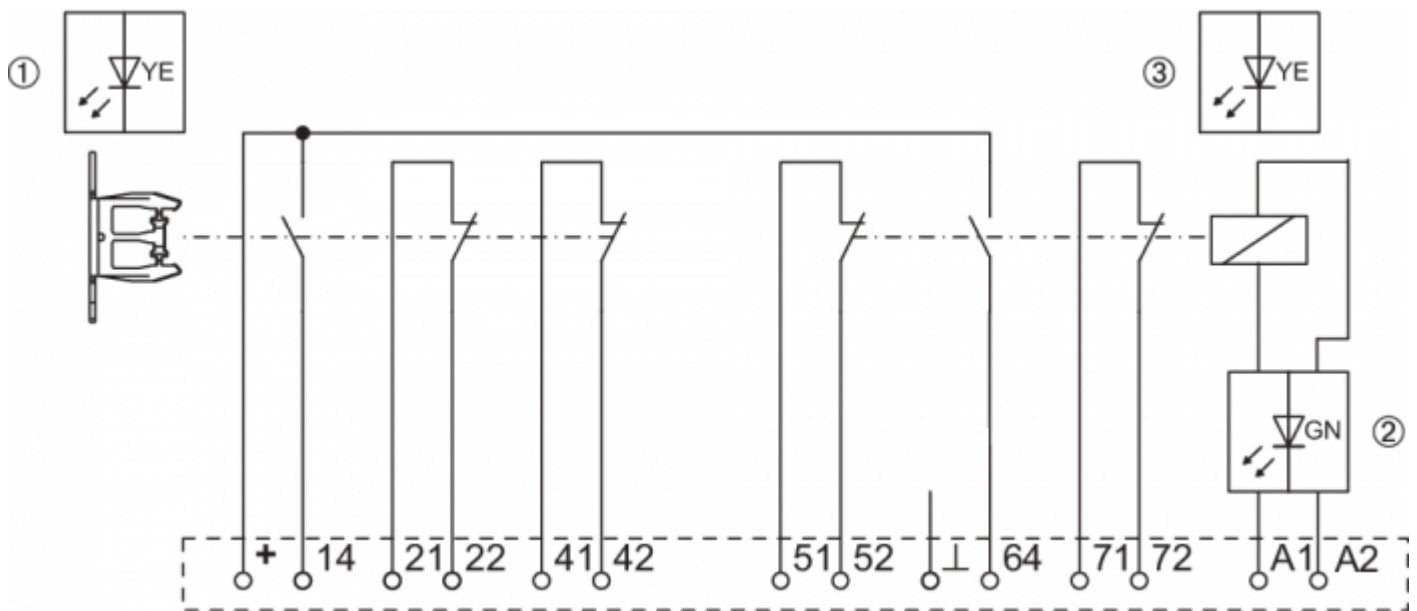

Die 24 V werden intern auf die Kontakte 13 und 63 geführt. Die zugehörigen Signale der LED-Anzeige können zusätzlich an den Klemmen 14 bzw. 64 abgegriffen werden.

Kontaktsatz 12/03 G (mit LED)

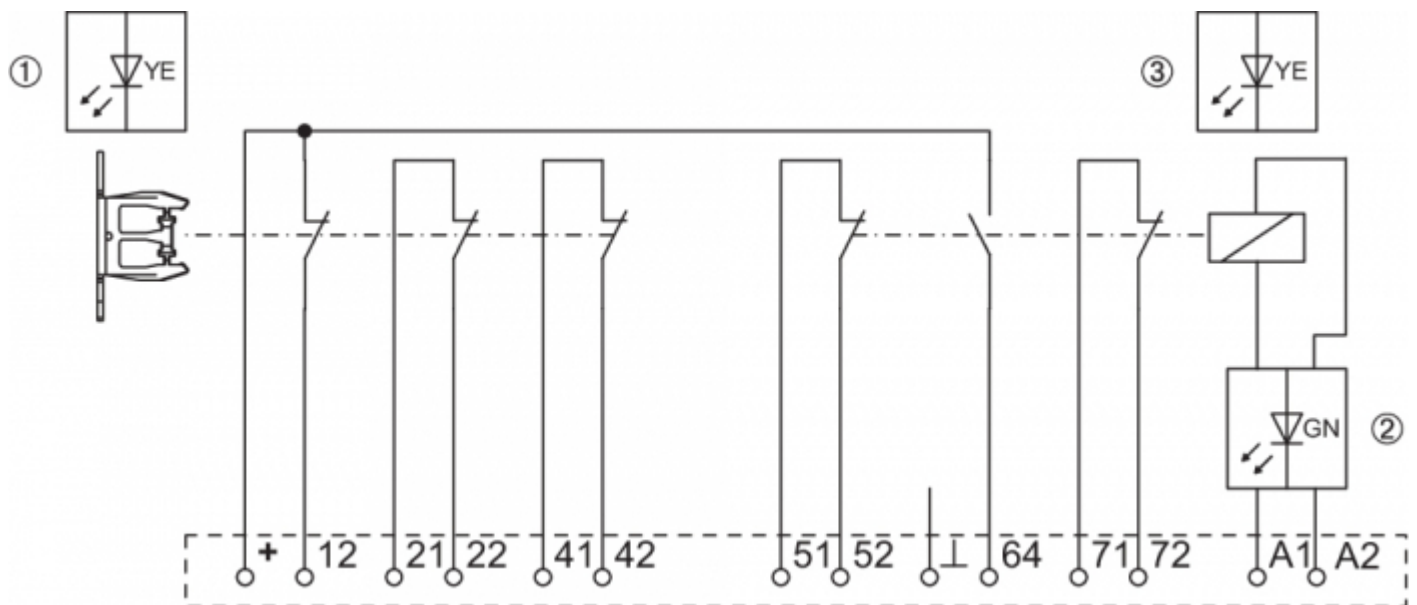

Die 24 V werden intern auf die Kontakte 11 und 63 geführt. Die zugehörigen Signale der LED-Anzeige können zusätzlich an den Klemmen 12 bzw. 64 abgegriffen werden.

Legende	
①	Tür geschlossen
②	Magnet ein
③	Tür gesperrt

Ruhestromprinzip				
Systemzustand	Magnetansteuerung		LED	
	Ruhestrom	gelb ①	rot ②	gelb ③
Tür auf	24 V (0 V)	aus	an	aus
Tür geschlossen, Betätiger eingeführt, nicht gesperrt	24 V	an	an	aus
Tür geschlossen, Betätiger eingeführt, und gesperrt	0 V	an	aus	an

Arbeitsstromprinzip				
Systemzustand	Magnetansteuerung		LED	
	Arbeitsstrom	gelb ①	rot ②	gelb ③
Tür auf	0 V (24 V)	aus	aus	aus
Tür geschlossen, Betätiger eingeführt, nicht gesperrt	0 V	an	aus	aus
Tür geschlossen, Betätiger eingeführt, und gesperrt	24 V	an	an	an

5 Inbetriebnahme und Wartung

Das Sicherheitsschaltgerät ist hinsichtlich seiner Sicherheitsfunktion zu testen. Bei ordnungsgemäßer Installation und bestimmungsgemäßer Verwendung arbeitet das Sicherheitsschaltgerät wartungsfrei. In regelmäßigen Abständen empfehlen wir eine Sicht- und Funktionsprüfung mit folgenden Schritten:

1. Sicherheitsschaltgerät und Betätiger auf festen Sitz prüfen.
2. Unversehrtheit der Leitungsanschlüsse prüfen.
3. Entfernen von Schmutzresten.



In allen betriebsmäßigen Lebensphasen des Sicherheitsschaltgerätes sind konstruktiv und organisatorisch geeignete Maßnahmen zum Manipulationsschutz beziehungsweise gegen das Umgehen der Sicherheitseinrichtung, beispielsweise durch Einsatz eines Ersatzbetätigers, zu treffen.



Beschädigte oder defekte Geräte sind auszutauschen.

6 Demontage und Entsorgung

6.1 Demontage

Das Sicherheitsschaltgerät ist nur in spannungslosem Zustand zu demontieren.

6.2 Entsorgung



Das Sicherheitsschaltgerät ist entsprechend der nationalen Vorschriften und Gesetze fachgerecht zu entsorgen.