

INSTRUCTIONS POUR FONCTIONNEMENT ET MONTAGE

Capteur de sécurité électronique RSS260-123456 Test

Table of Contents

- 1 About this document
 - 1.1 Function
 - 1.2 Target group of the operating instructions: authorised qualified personnel
 - 1.3 Explanation of the symbols used
 - 1.4 Appropriate use
 - 1.5 General safety instructions
- 2 Product description
 - 2.1 Ordering code
 - 2.2 Special versions
 - 2.3 Purpose
 - 2.4 Warning about misuse
 - 2.5 Exclusion of liability
- 3 Technical Data
- 4 Mounting
 - 4.1 General mounting instructions
 - 4.2 Actuating directions
 - 4.3 Dimensions
 - 4.4 Accessories
 - 4.5 Switch distance
 - 4.6 Adjustment
- 5 Electrical connection
 - 5.1 General information for electrical connection
 - 5.2 Serial diagnostic -SD
 - 5.3 Wiring examples for series-wiring
 - 5.4 Wiring configuration and connector accessories
- 6 Actuator coding
- 7 Working principle and diagnostic function
 - 7.1 Mode of operation of the safety outputs
 - 7.2 Diagnostic-LEDs
 - 7.3 Operating principle of the electronic diagnostic output
 - 7.4 Safety-sensors with serial diagnostic function
- 8 Set-up and maintenance
- 9 Disassembly and disposal
 - 9.1 Disassembly
 - 9.2 Disposal

1 About this document

1.1 Function

This document provides all the information you need for the mounting, set-up and commissioning to ensure the safe operation and disassembly of the switchgear. The operating instructions enclosed with the device must always be kept in a legible condition and accessible.

1.2 Target group of the operating instructions: authorised qualified personnel

All operations described in the operating instructions manual must be carried out by trained specialist personnel, authorised by the plant operator only.

Please make sure that you have read and understood these operating instructions and that you know all applicable legislations regarding occupational safety and accident prevention prior to installation and putting the component into operation.

The machine builder must carefully select the harmonised standards to be complied with as well as other technical specifications for the selection, mounting and integration of the components.

The information contained in this operating instructions manual is provided without liability and is subject to technical modifications.

1.3 Explanation of the symbols used



Information, hint, note: This symbol is used for identifying useful additional information.



Caution: Failure to comply with this warning notice could lead to failures or malfunctions.

Warning: Failure to comply with this warning notice could lead to physical injury and/or damage to the machine.

1.4 Appropriate use

The Schmersal range of products is not intended for private consumers.

The products described in these operating instructions are developed to execute safety-related functions as part of an entire plant or machine. It is the responsibility of the manufacturer of a machine or plant to ensure the correct functionality of the entire machine or plant.

The safety switchgear must be exclusively used in accordance with the versions listed below or for the applications authorised by the manufacturer. Detailed information regarding the range of applications can be found in the chapter "Product description".

1.5 General safety instructions

The user must observe the safety instructions in this operating instructions manual, the country specific installation standards as well as all prevailing safety regulations and accident prevention rules.



Further technical information can be found in the Schmersal catalogues or in the online catalogue on the Internet:

products.schmersal.com.

2 Product description

2.1 Ordering code

Product type description: RSS260-(1)-(2)-(3)-(4)-(5)	
(1)	
without	Standard coding
I1	Individual coding
I2	Individual coding, multiple teaching
(2)	
D	With diagnostic output
SD	With serial diagnostic function
(3)	
without	Standard version without feedback circuit monitoring EDM (External Device Monitoring)
F0	EDM with automatic reset
F1	EDM with manual reset
(4)	
without	without emergency-stop
Q	Acknowledge input error with EMERGENCY STOP
(5)	
without	Connecting cable (length in m)

ST	Connector plug M8, 8-pole
LSTM12-8-0,25M	Cable 0.25 m long with connector M12, 8-pole
LSTM8-8-0,1M	Cable 0.1 m long with connector M8, 8-pole
LSTM12-5-0.25M	Cable 0.25 m long with connector M12, 5-pole

2.2 Special versions

For special versions, which are not listed in the ordering code, these specifications apply accordingly, provided that they correspond to the standard version.

2.3 Purpose

This non-contact, electronic safety sensor is designed for application in safety circuits and is used for monitoring the position of movable safety guards. In this application, the safety sensor monitors the position of hinged, sliding or removable safety guards by means of the coded electronic actuator.

The safety function consists of safely switching off the safety outputs when the safety guard is opened and maintaining the safe switched off condition of the safety outputs for as long as the safety guard is open.



The safety switchgears are classified according to EN ISO 14119 as type 4 interlocking devices. Designs with individual coding are classified as highly coded.

With the F0/F1 option, the sensor performs the tasks of a safety-monitoring module. At both safety outputs, two auxiliary contactors¹⁾ or Relays¹⁾ (¹⁾ each with positive-action contacts in accordance with EN 60947-5-1 or EN 50205) can be connected, whose safety-related function is checked by the sensor by means of a feedback circuit (External Device Monitoring). The feedback circuit includes the series-wiring of the NC contacts of the auxiliary contactors or relays. For the F0 version, an "enabling switch" (without safety function) can be integrated into the feedback circuit. For the F1 version, a so-called "reset button" is required, which is monitored for a trailing edge. This function corresponds to the "manual reset function" to EN ISO 13849-1.

The Q option monitors simultaneous shutdown of the sensor inputs. Series-wired sensors enable integration of EMERGENCY STOP switching elements for applications to PLe. The EMERGENCY STOP contacts are supplied by the cross-circuit monitored output signals of an upstream electronic safety switchgear device. At the end of the chain, a sensor with Q option for connecting an acknowledgement function monitors the chain for synchronous shutdown of both channels. In the event of erroneous shutdown, the error must be rectified. The safety outputs can be reactivated only once the error has been acknowledged.

The diagnostic output of the safety sensor alternatively can be used as a conventional output or as a "serial output" with input and output channel.

Series-wiring

Series-wiring can be set up. In the case of a series connection, the risk time remains unchanged and the reaction time increases by the sum of the reaction time of the inputs per additional unit specified in the technical data. The quantity of devices is only limited by the cable drops and the external cable fuse protection, according to the technical data. Up to 31 device variants with serial diagnostics can be wired in series.



The user must evaluate and design the safety chain in accordance with the relevant standards and the required safety level. If multiple safety sensors are involved in the same safety function, the PFH values of the individual components must be added.



The entire concept of the control system, in which the safety component is integrated, must be validated to the relevant standards.

2.4 Warning about misuse



In case of improper use or manipulation of the safety switchgear, personal hazards or damages to machinery or plant components cannot be excluded. There are no residual risks, provided that the safety instructions as well as the instructions regarding mounting, commissioning, operation and maintenance are observed.

2.5 Exclusion of liability

We shall accept no liability for damages and malfunctions resulting from defective mounting or failure to comply with the operating instructions manual. The manufacturer shall accept no liability for damages resulting from the use of unauthorised spare parts or accessories.

For safety reasons, invasive work on the device as well as arbitrary repairs, conversions and modifications to the device are strictly forbidden, the manufacturer shall accept no liability for damages resulting from such invasive work, arbitrary repairs, conversions and/or modifications to the device.

3 Technical Data

Homologations - Règlements

Certificates	TÜV cULus FCC IC UKCA
--------------	-----------------------------------

Caractéristiques globales

Standards	EN IEC 60947-5-3
Coding	Codage universel
Coding level according to EN ISO 14119	faible
Working principle	RFID
Housing construction form	Bloc
Installation conditions (mechanical)	non affleuré

Sensor topology	Connexion en série
Housing material	Plastique, thermoplastique, auto-extinguible
Active area	Plastique, thermoplastique
Reaction time, maximum	100 ms
Duration of risk, maximum	200 ms
Gross weight	47 g

Données générales - Caractéristiques

Diagnostic output	Oui
Short circuit detection	Oui
Cross-circuit detection	Oui
Safety functions	Oui
Cascadable	Oui
Integral system diagnostics, status	Oui
Number of LEDs	3
Number of semi-conductor outputs with signaling function	1
Number of fail-safe digital outputs	2

Classification

Standards	EN ISO 13849-1 EN IEC 60947-5-3 EN IEC 62061 EN IEC 61508
Performance Level, up to	e
Category	4
PFH value	$6,80 \times 10^{-10}$ /h
Safety Integrity Level (SIL), suitable for applications in	3
Mission time	20 Year(s)

Données mécaniques

Actuating panels	latéral côté avant
Active area	latéral avant
Mounting	Pour le montage des capteurs, des vis longues de 20 mm conviennent de façon générale. Lorsque les plaques de montage sont utilisées, des vis longues de 25 mm sont recommandées.

Données mécaniques - Distances de commutation selon EN IEC 60947-5-3

Switching distance S_n	avant 12 mm latéral 9 mm
Assured switching distance "ON", frontal	10 mm
Assured switching distance "OFF", frontal	18 mm
Assured switching distance "ON", lateral	6 mm
Assured switching distance "OFF", lateral	15 mm
Hysteresis (Switching distance), maximum	2 mm
Repeat accuracy R	0,5 mm
Note (Repeat accuracy R)	Décalage latéral: le côté long permet un décalage en hauteur (x) entre le capteur et l'actionneur est de max. 8 mm (p.ex. suite aux erreurs de montage ou au désalignement du protecteur). Le décalage transversal (y) s'élève à max. ± 10 mm (voir dessin: principe de fonctionnement). Distance minimale 100 mm en cas d'attaque latérale

Données mécaniques - technique de connexion

Note (length of the sensor chain)	Cable length and cross-section change the voltage drop depending on the output current
Termination	Connecteur multibroches M8

Données mécaniques - Dimensions

Length of sensor	29,5 mm
Width of sensor	39,2 mm
Height of sensor	18 mm

Conditions ambiantes

Degree of protection	IP65 IP67
Ambient temperature	-25 ... +65 °C
Storage and transport temperature	-25 ... +85 °C
Resistance to vibrations	10...55 Hz, amplitude 1 mm
Resistance to shock	30 g / 11 ms

Conditions ambiantes - Valeur d'isolation

Rated insulation voltage U_i	32 VDC
--------------------------------	--------

Rated impulse withstand voltage U_{imp}	0,8 kV
Overvoltage category	III
Degree of pollution	3

Données électriques

Operating voltage	24 VDC -15 % / +10 %
No-load supply current I_0 , typical	100 mA
Rated operating voltage	24 VDC
Operating current	600 mA
Required rated short-circuit current	100 A
Time to readiness, maximum	2 000 ms
Switching frequency, approx.	1 Hz
Utilisation category DC-12	24 VDC / 0,05 A

Données électriques - Sorties de sécurité

Design of control elements	commutation P
Voltage drop U_d , maximum	1 V
Leakage current I_r , maximum	0,5 mA
Voltage, Utilisation category DC-12	24 VDC
Current, Utilisation category DC-12	0,25 A
Voltage, Utilisation category DC-13	24 VDC
Current, Utilisation category DC-13	0,25 A

Données électriques - Sortie diagnostique "OUT"

Design of control elements	à commutation P
Voltage drop U_d , maximum	2 V
Voltage, Utilisation category DC-12	24 VDC
Current, Utilisation category DC-12	0,05 A
Voltage, Utilisation category DC-13	24 VDC
Current, Utilisation category DC-13	0,05 A

Données électriques - Compatibilité électromagnétique (CEM)

Interfering radiation	IEC 61000-6-4
EMC rating	IEC 60947-3

Indication d'état par

Note (LED switching conditions display)

LED jaune: état de fonctionnement
LED verte: tension d'alimentation
LED rouge: défaut

Affectation des broches

PIN 1	A1 U _e : blanc
PIN 2	X1 Entrée de sécurité 1: marron
PIN 3	A2 GND: vert
PIN 4	Y1 Sortie de sécurité 1: jaune
PIN 5	OUT Sortie diagnostic "OUT" OUT gris
PIN 6	X2 Entrée de sécurité 2: rose
PIN 7	Y2 Sortie de sécurité 2: bleu
PIN 8	IN sans fonction: rouge

UL notice



For use in NFPA 79 applications. Adapters that enable field wiring are available from the manufacturer. Observe the manufacturer's information. For use in Pollution Degree 2 Environment.

FCC/IC - Note

This device complies with Part 15 of the FCC Rules and contains licence-exempt transmitter/receivers that are compliant with ISED (Innovation, Science and Economic Development) Canada licence-exempt RSS standard(s). Operation is subject to the following two conditions:

- (1) This device may not cause harmful interference signals, and
- (2) This device must be able to tolerate interference signals. These also include interference signals that could cause the device to function improperly.

This device complies with the nerve stimulation limits (ISED SPR-002) when operated at a minimum distance of 100 mm. Changes or modifications not expressly approved by K.A. Schmersal GmbH & Co. KG could void the user's authority to operate the equipment.

The licence-free transmitter/receiver contained in this device satisfies the requirements of the "Radio Standards Specification" of the Innovation, Science and Economic Development Canada (ISED) authority that apply to licence-free radio equipment. Operation is permissible under the following two conditions:

- (1) The device must not create disturbances.
- (2) The device must tolerate received radio frequency interference, even if this could impair its functionality.

This device complies with the nerve stimulation limits (ISED CNR-102) when operated at a minimum distance of 100 mm.

In the event of changes or modifications that have not been expressly approved by K.A. Schmersal GmbH & Co. KG, the user's authorisation to use the device may become ineffective.



20941-22-14519

Este equipamento não tem direito à proteção contra interferência prejudicial e não pode causar interferência em sistemas devidamente autorizados.

9-33 Para maiores informações consultar:

4 Mounting

4.1 General mounting instructions



During fitting, the requirements of EN ISO 12100, EN ISO 14119 and EN ISO 14120 must be observed.

The mounting holes provide for a variable mounting by means of M4 screws (max. tightening torque 0.8 Nm). The component can be mounted in any position. The minimum bend radius of the cable- resp. LST-variants is 25 mm.

The active areas of the sensor and the actuator have to face each other. The safety sensor must only be used within the assured switching distances \leq sao and \geq sar.



The actuator must be permanently fitted to the safety guards and protected against displacement by suitable measures (tamperproof screws, gluing, drilling of the screw heads).

To avoid any interference inherent to this kind of system and any reduction of the switching distances, please observe the following guidelines:

- The presence of metal chips in the vicinity of the sensor is liable to modify the switching distance.
- Keep away from metal chips

Minimum distance between two safety sensors as well as other systems with same frequency (125 kHz):

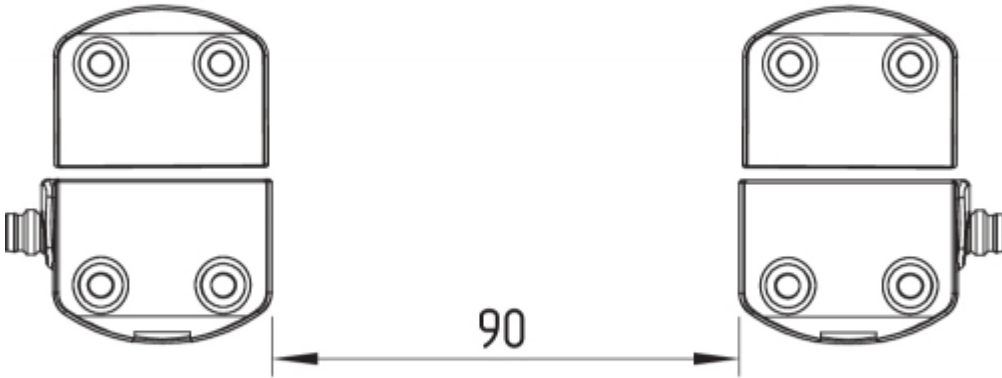
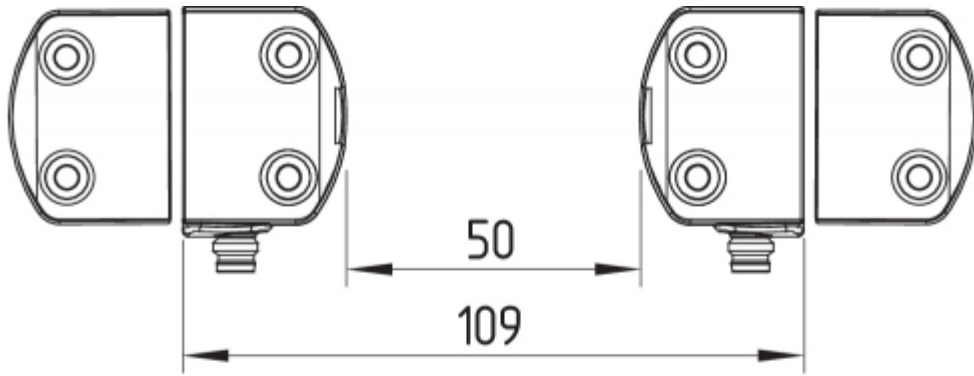

4.2 Actuating directions

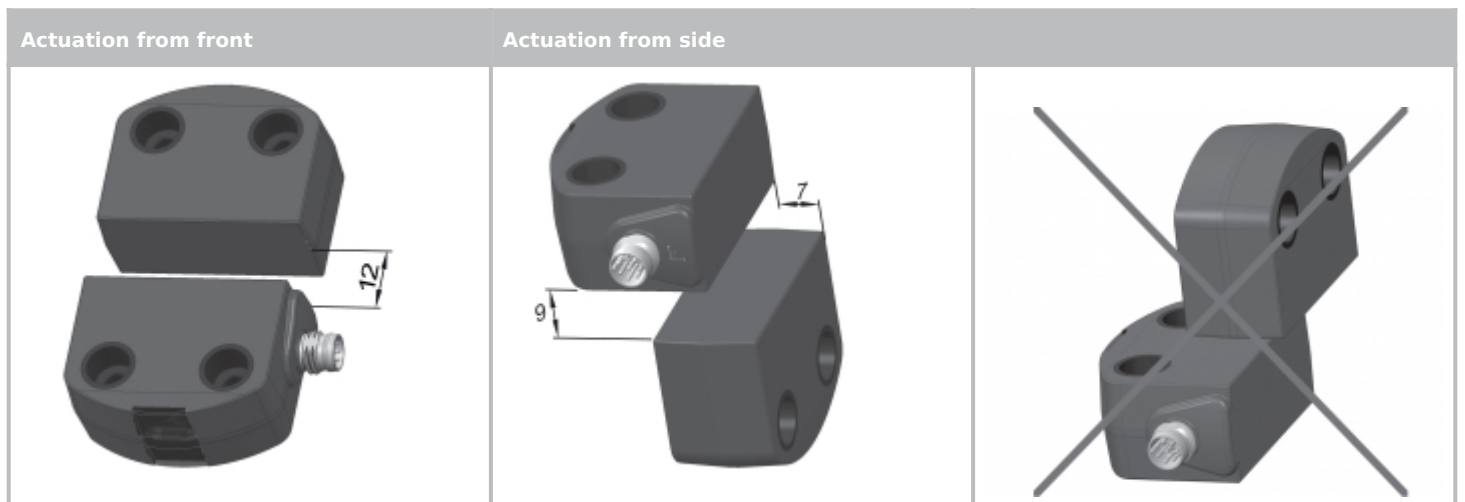



Lateral actuation only from the shown sensor side

4.3 Dimensions

All measurements in mm.

Safety sensor with integrated cable

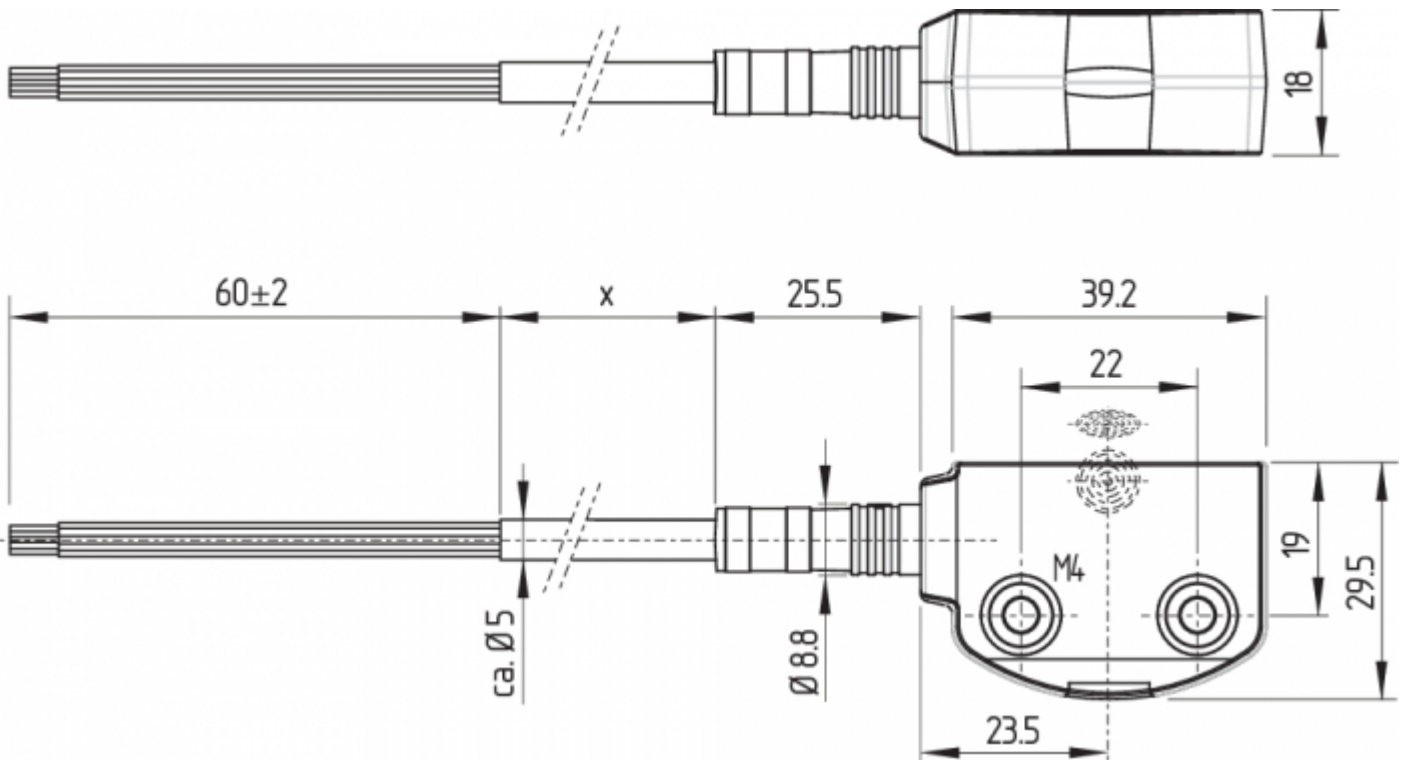

Key

x

Cable length

Safety sensor RSS260-...-ST

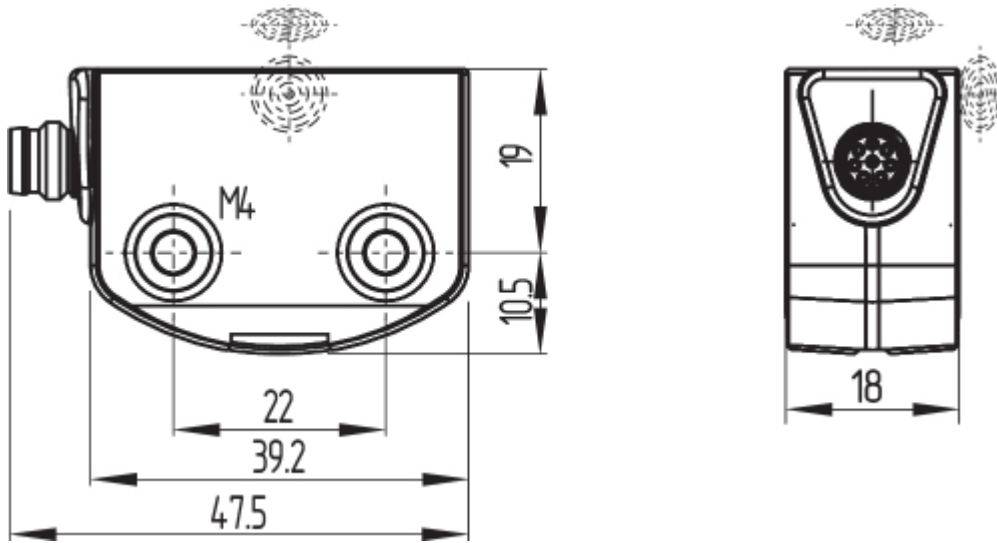

Safety sensor RSS260-...-LSTM12

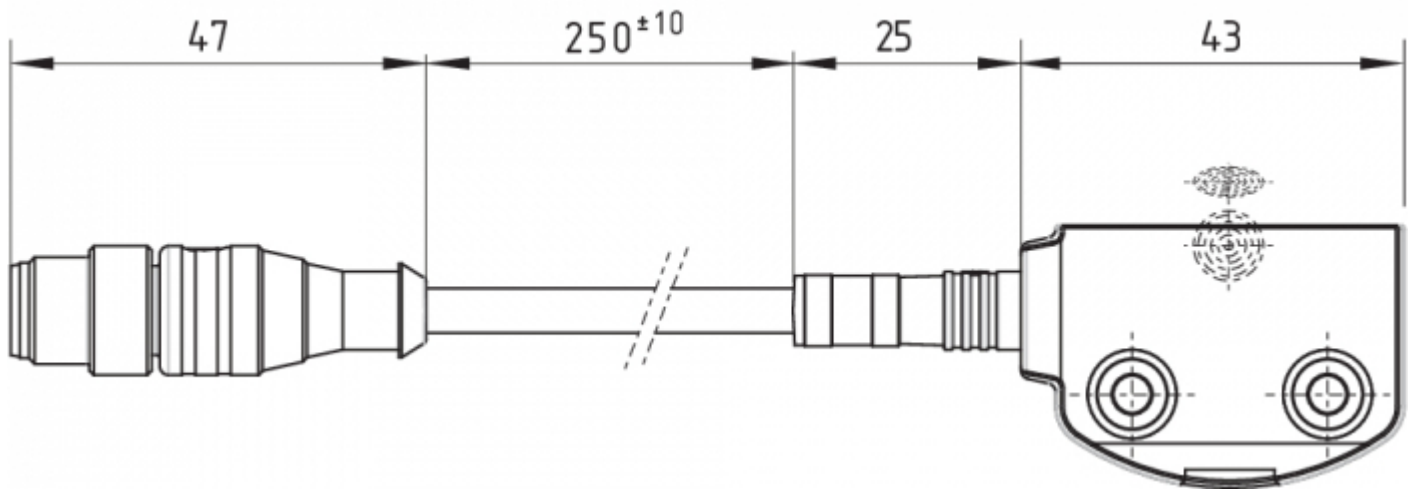

Safety sensor RSS260-...-LSTM8

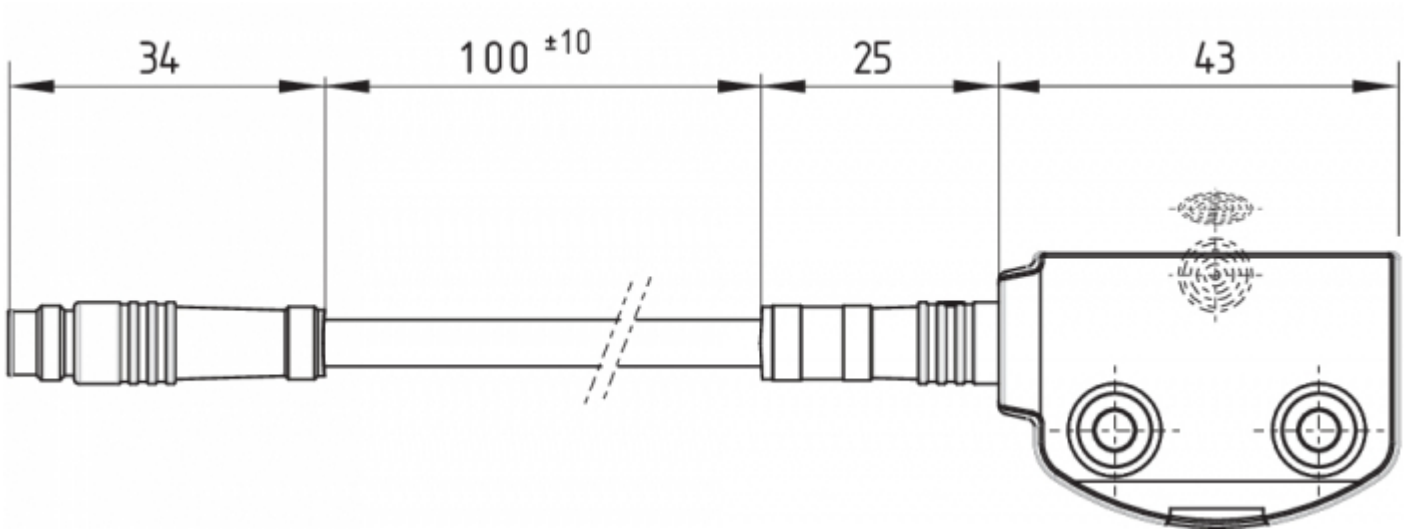

Actuator: RST260-1

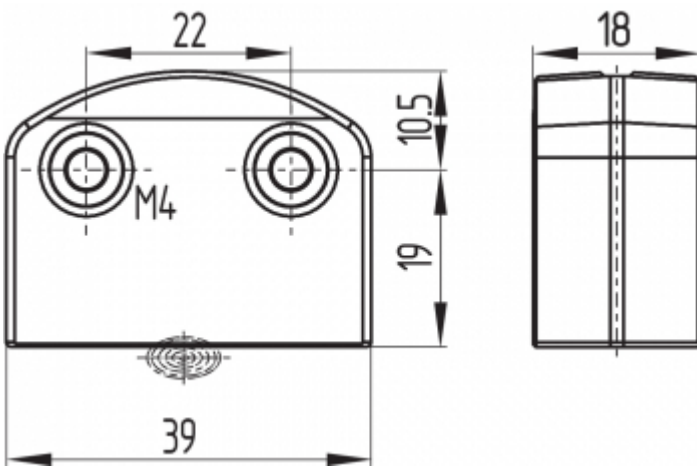

Key	
	active area

Alternative suitable actuators with different design: refer to products.schmersal.com.

4.4 Accessories

Set of disposable screws (order separately)

- 4x M4x25 incl. washers, order number 101217746
- 4x M4x30 incl. washers, Bestellnummer 101217747

Sealing kit (order separately)

- Order number 101215048
- 8 plugs and 4 under seals
- To seal the mounting holes and as a spacer (approx. 3 mm) to facilitate cleaning below the mounting surface
- Also suitable as tamper protection for the screw attachment

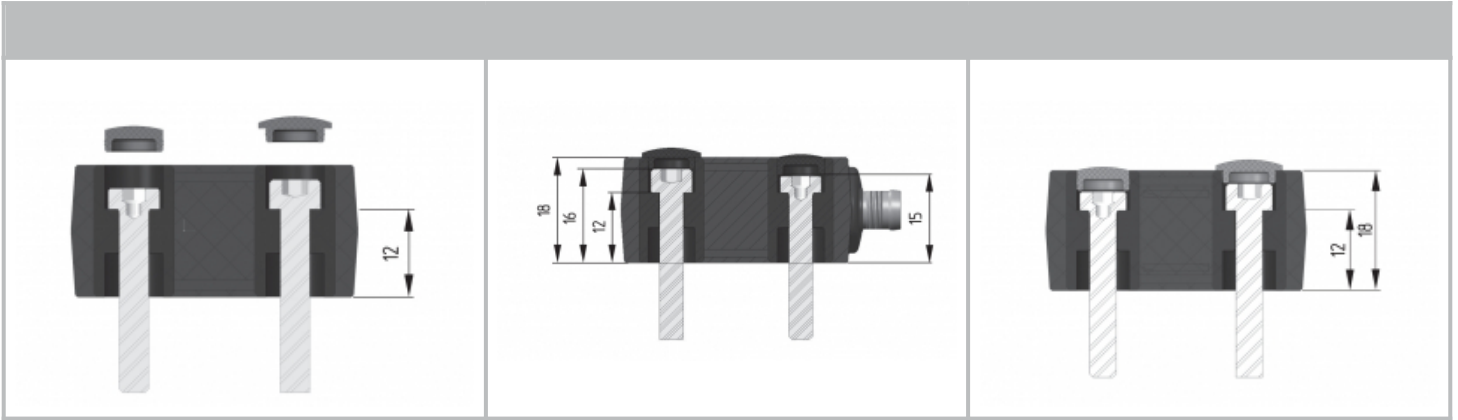

Assembly kit (to be ordered separately)

- ordering number 103005469
- Alternative use of mounting plates or ferrules
- Mounting plates: 2x for assembly on non-flat surfaces, e.g. on grooved profiles
- Ferrules: 4x for insertion to secure the screw fixings to the mounting surface for applications with regular high temperature variations

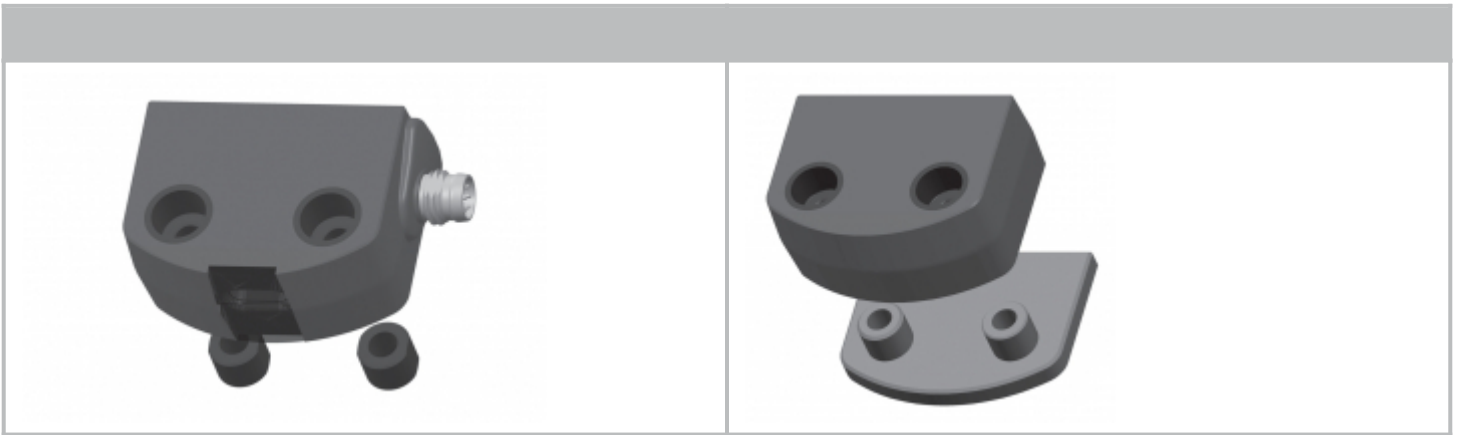

4.5 Switch distance

The side allows for a maximum height misalignment (X) of sensor and actuator of ± 8 mm (e.g. mounting tolerance or due to guard door sagging). The axial misalignment (y) is max. ± 18 mm.

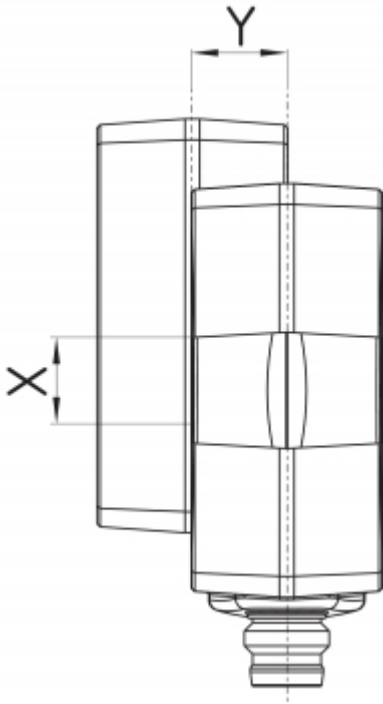

Actuating curves

The actuating curves represent the typical switching distance of the safety sensor during the approach of the actuator subject to the actuating direction

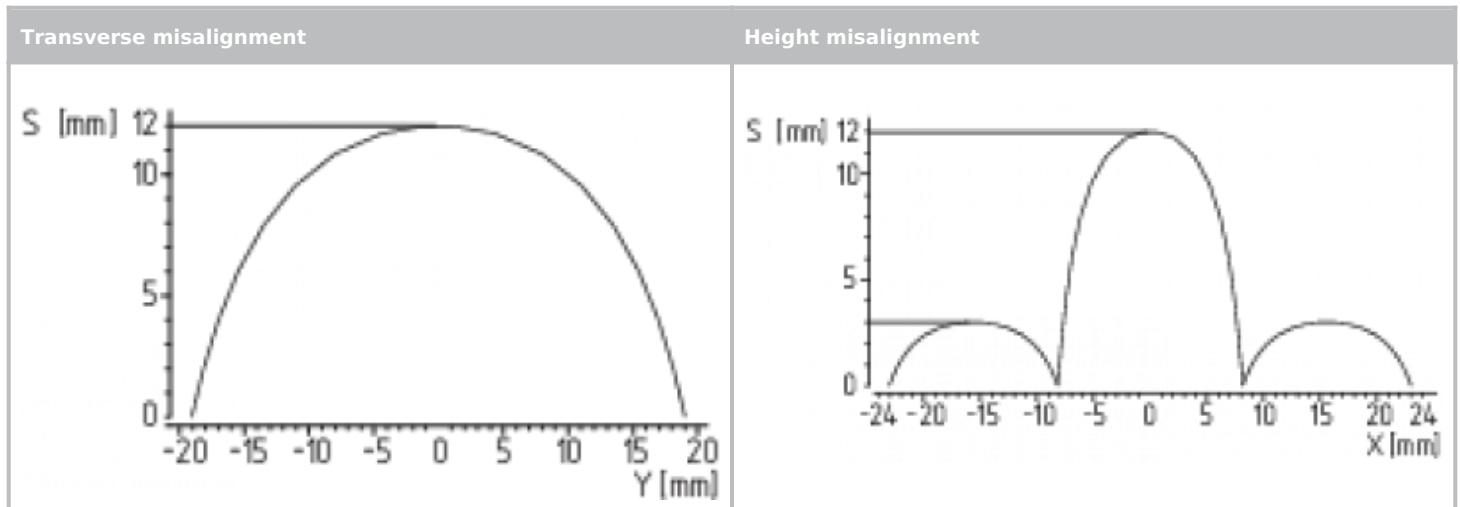

Preferred actuation directions: from front or from side In case of a lateral actuation, the switching distances are reduced by approx. 3 mm.

4.6 Adjustment

The continuous signal of the yellow LED signals the actuator detection; the flashing of the yellow LED signals that the safety sensor is actuated in the hysteresis area.



Recommended Adjustment

Align the safety sensor and actuator at a distance of $0.5 \times s_{a0}$.

The correct functionality of both safety channels must be checked by means of the connected safety-monitoring module.

5 Electrical connection

5.1 General information for electrical connection



The electrical connection may only be carried out by authorised personnel in a de-energised condition.

The safety outputs can be integrated into the safety circuit of the control system. For applications of PL e / category 4 to EN ISO 13849-1, the safety outputs of the safety sensor or of the sensor chain must be wired to a safety monitoring-module of the same category.

The required electrical cable fuse protection must be integrated in the installation.

Protection is not required when pilot wires are laid. The cables however must be separated from the supply and energy cables. The max. fuse rate for a sensor chain depends on the section of the connecting cable of the sensor.

Requirements for the connected safety-monitoring module:

dual-channel safety input, suitable for p-type sensors with NO function



Information for the selection of suitable safety-monitoring modules can be found in the Schmersal catalogues or in the online catalogue on the Internet: products.schmersal.com

As an alternative to an evaluation unit, the safety sensors of the RSS260..F0 resp. RSS260...F1 series can also be used for direct control and monitoring of safety contactors as first sensor of a series-wired chain.

The sensors cyclically switch off the safety output to test them. The safety-monitoring module therefore does not need to be equipped with a cross-wire short detection. The switch-off times must be tolerated by the safety-monitoring module. The switch -off time of the safety sensor is additionally extended depending on the cable length and the capacity of the cable used. Typically, a switch-off time of 250 μ s is reached with a 30-m connecting cable.



Configuration of the safety-monitoring module

If the safety sensor is connected to electronic safety-monitoring modules, we recommend that you set a discrepancy time of min. 100 ms. The safety inputs of the safety-monitoring module must be able blanking a test impulse of approx. 1 ms. The safety-monitoring module does not need to have a cross-wire short monitoring function, if necessary, the cross-wire short monitoring function must be disabled.

5.2 Serial diagnostic -SD

Cable design

The wiring capacitance of the connecting cable of the safety sensor must not exceed 50 nF.

Depending on the strand structure, normal unshielded 30 m long control cables LIYY 0.25 (0.14) mm² to 1.5 mm² have a wiring capacitance of approx. 3 ... 7 nF.



On wiring SD devices, please pay attention to the voltage drop on the cables and the current carrying capacity of the individual components.



Accessories for the series-wiring

For convenient wiring and series-wiring of SD components, the SD junction boxes PFB-SD-4M12-SD (variant for the field) and PDM-SD-4CC-SD (variant for control cabinet on carrier rail) are available along with additional comprehensive accessories.

Detailed information is available on the Internet, products.schmersal.com.

5.3 Wiring examples for series-wiring

Series-wiring can be set up. In the case of a series connection, the risk time remains unchanged and the reaction time increases by the sum of the reaction time of the inputs per additional unit specified in the technical data. The number of components is only limited by the external cable protection according to the technical data and the line loss. Series-wiring of up to 31 RSS260 ... SD components with serial diagnostics is possible.

The application examples shown are suggestions. They however do not release the user from carefully checking whether the switchgear and its set-up are suitable for the individual application. The application examples shown are suggestions.

Wiring example 1: Series-wiring of the RSS 260 with conventional diagnostic output

The voltage is supplied to both safety inputs of the last safety sensor of the chain (considered from the safety-monitoring module).

The safety outputs of the first safety sensor are wired to the safety-monitoring module. The diagnostic output can be connected for instance to a PLC.

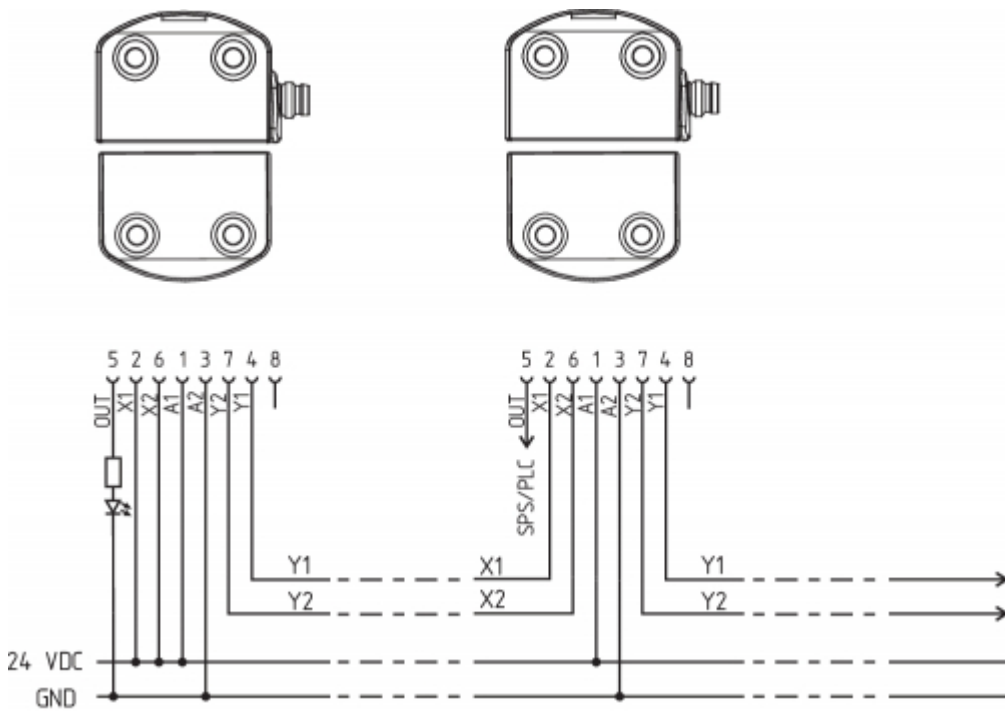

Y1 and Y2 = Safety outputs → Safety monitoring module

Wiring example 2: series-wiring of the RSS 260 with serial diagnostic function

In devices with the serial diagnostics function (ordering suffix -SD), the serial diagnostics connections are wired in series and connected to a SD-Gateway for evaluation purposes. The voltage is supplied to both safety inputs of the last safety sensor of the chain (considered from the safety-monitoring module).

The safety outputs of the first safety sensor are wired to the safety-monitoring module. The serial Diagnostic Gateway is connected to the serial diagnostic input of the first safety sensor.

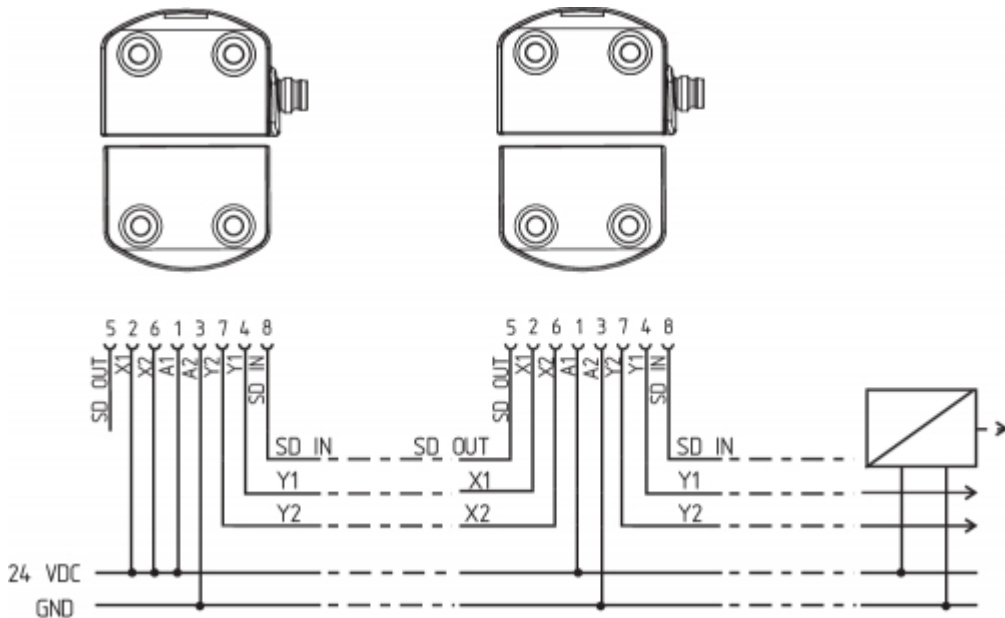

Y1 and Y2 = Safety outputs → Safety monitoring module
 SD-IN → Gateway → Field bus

Wiring example 3: Series-wiring with RSS260...F0

The safety sensor RSS 260 ...F0 directly controls positive-action auxiliary contactors or relays. The monitoring of the external contactors or relays is enabled by the feedback circuit, which is built by the NC contacts of K1, K2. As no further button is used, the auxiliary contactors or relays are immediately enabled when the safety guard is closed. This kind of automatic reset is permissible only if a hazard from the machine starting up can be ruled out.

The feedback circuit can be extended by an enabling button. The sensor is switched on, as soon as the enabling button is pushed. The design then corresponds analogously to the wiring examples of the F1 variants. The internal safety-monitoring module of variant F0 is not equipped with an edge detection for the button. If required, a "manual reset" to EN ISO 13849-1 must be realised by other components of a local control system.

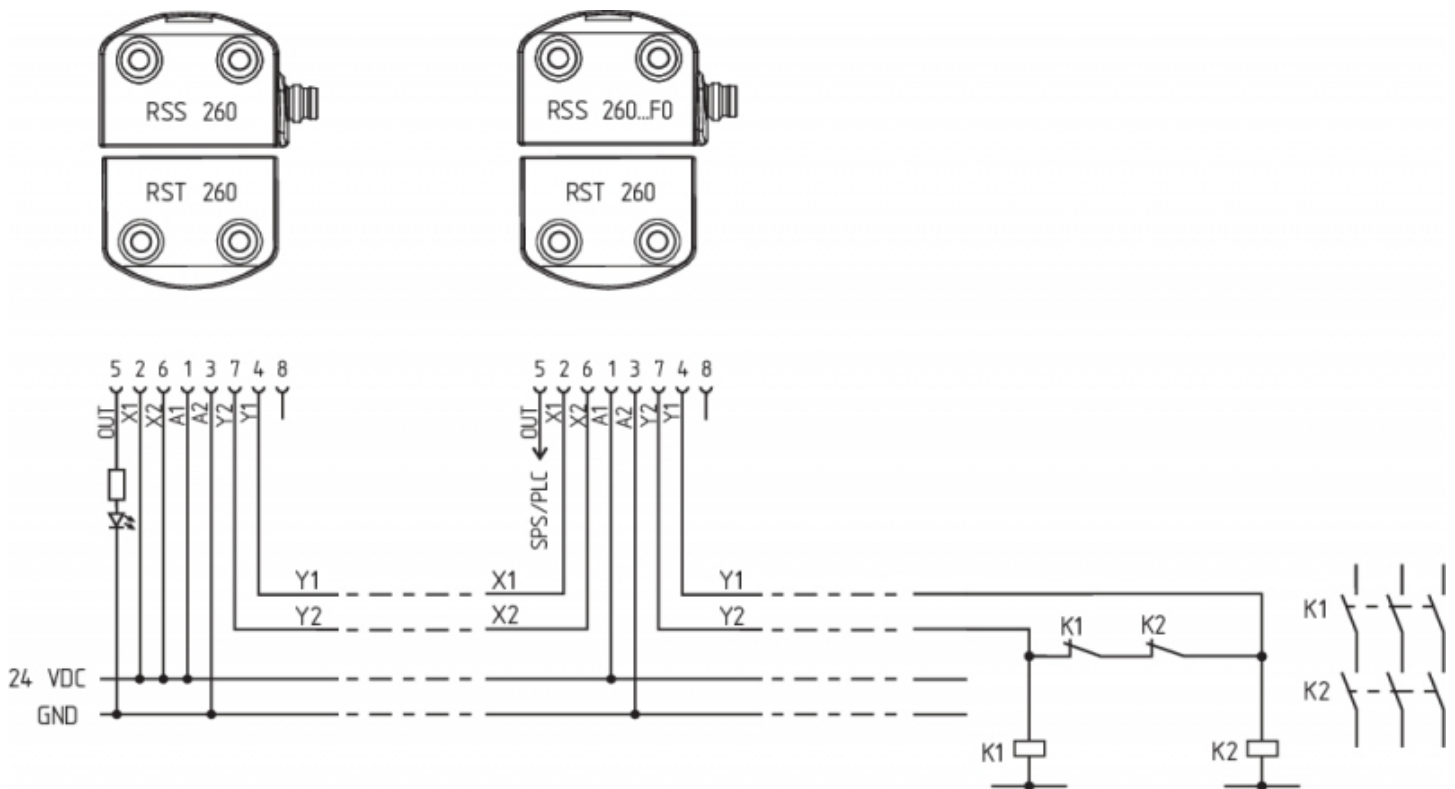

Wiring example 4: Series-wiring with RSS260...F1-Q as master with EDM

The safety sensor RSS 260...F1 directly controls positive-action auxiliary contactors or relays. The F1 function also monitors a trailing edge of the reset button in addition to the feedback contacts. The sensor switches on when the button is released. It can be used for manual reset on safety guards, which can be stepped over. The protected area must be designed so that a single reset button suffices. The Q function monitors EMERGENCY STOP buttons integrated into the chain and requires a separate error acknowledgement button.

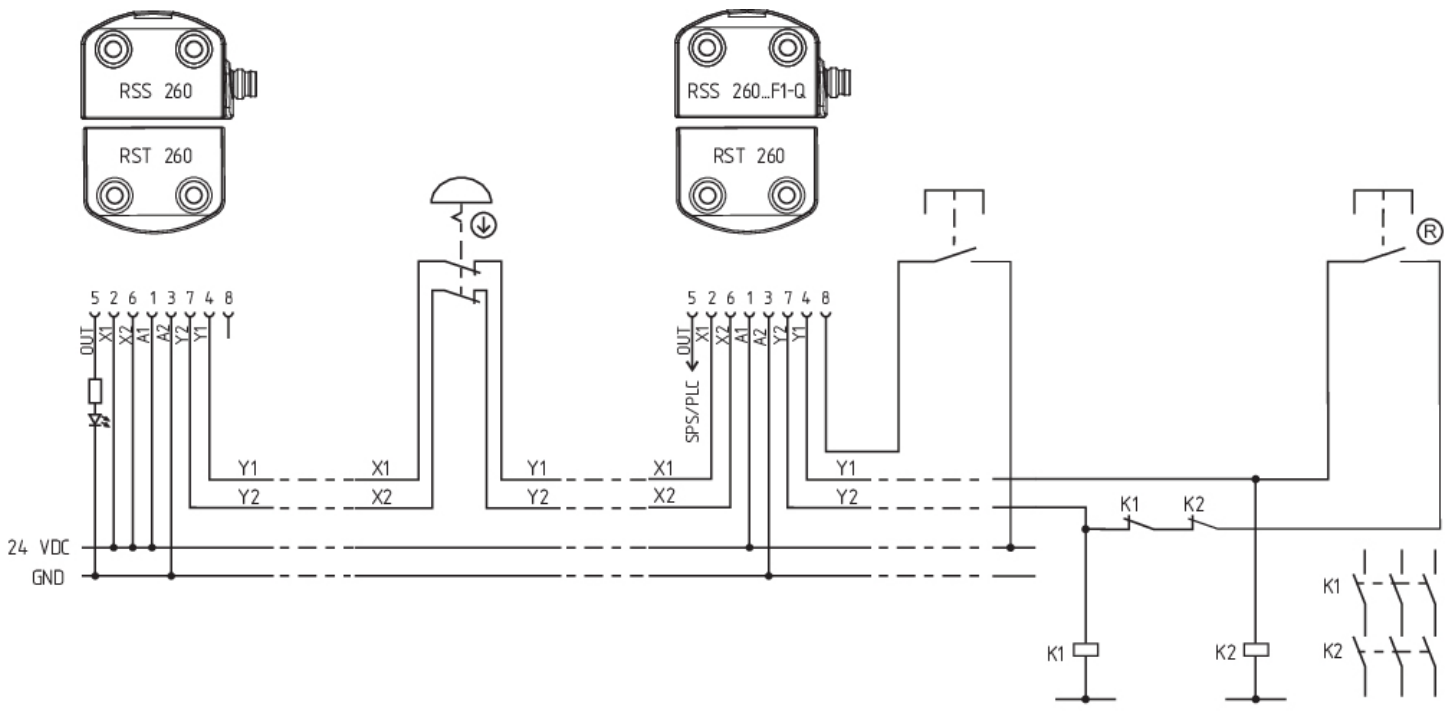

Wiring example 5: Series-wiring with RSS260...SD-F1-Q as master with EDM and serial diagnostics

The safety sensor RSS 260...F1 directly controls positive-action auxiliary contactors or relays. The F1 function also monitors a trailing edge of the reset button in addition to the feedback contacts. The sensor switches on when the button is released. It can be used for manual reset on safety guards, which can be stepped over. The protected area must be designed so that a single reset button suffices. The Q function monitors the EMERGENCY STOP buttons integrated into the chain. In the event of erroneous EMERGENCY STOP signals, the error message must be reset via the serial diagnostic channel using Q monitoring

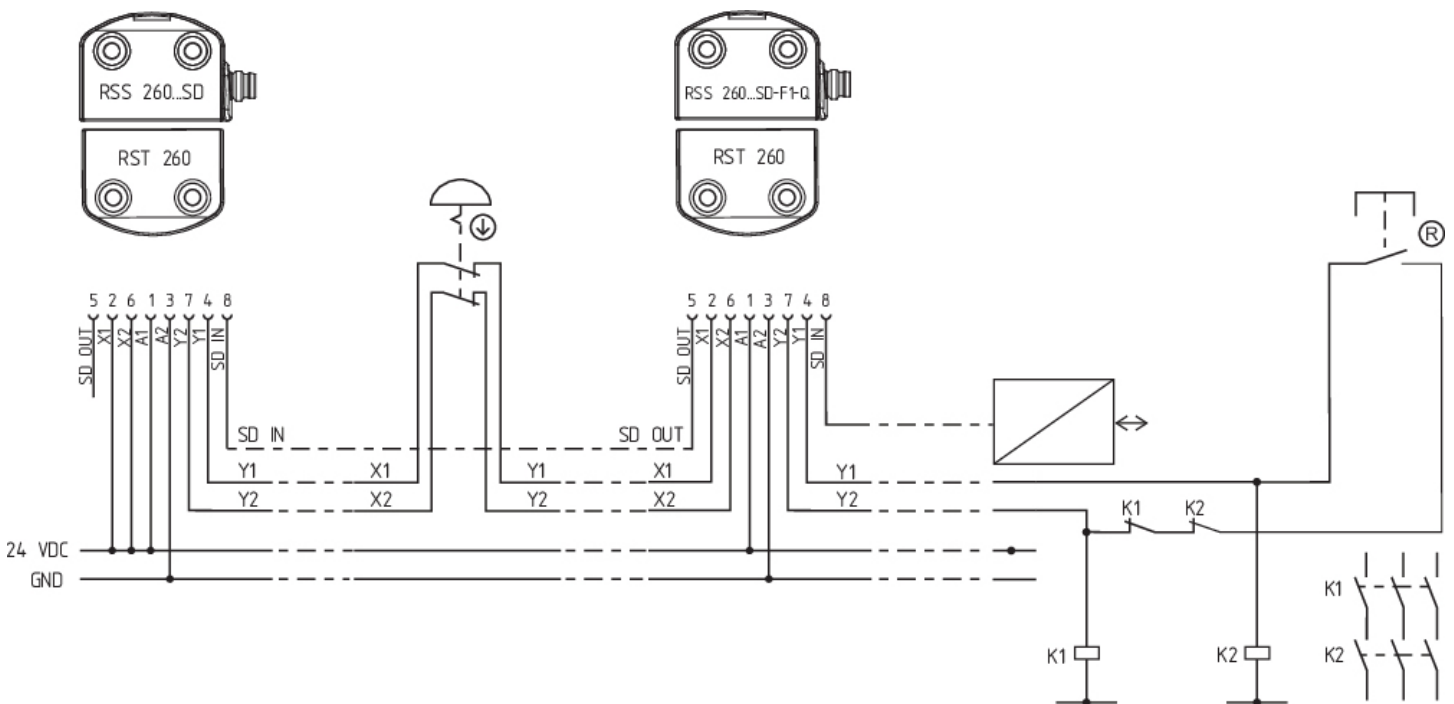

Wiring example 6: Series-wiring with RSS260...F1-Q with mixed components

The safety sensor RSS 260...F1 directly controls positive-action auxiliary contactors or relays. The F1 function also monitors a trailing edge of the reset button in addition to the feedback contacts. The sensor switches on when the button is released. It can be used for manual reset on safety guards, which can be stepped over. The protected area must be designed so that a single reset button suffices. The Q function monitors EMERGENCY STOP buttons integrated into the chain and requires a separate error acknowledgement button.

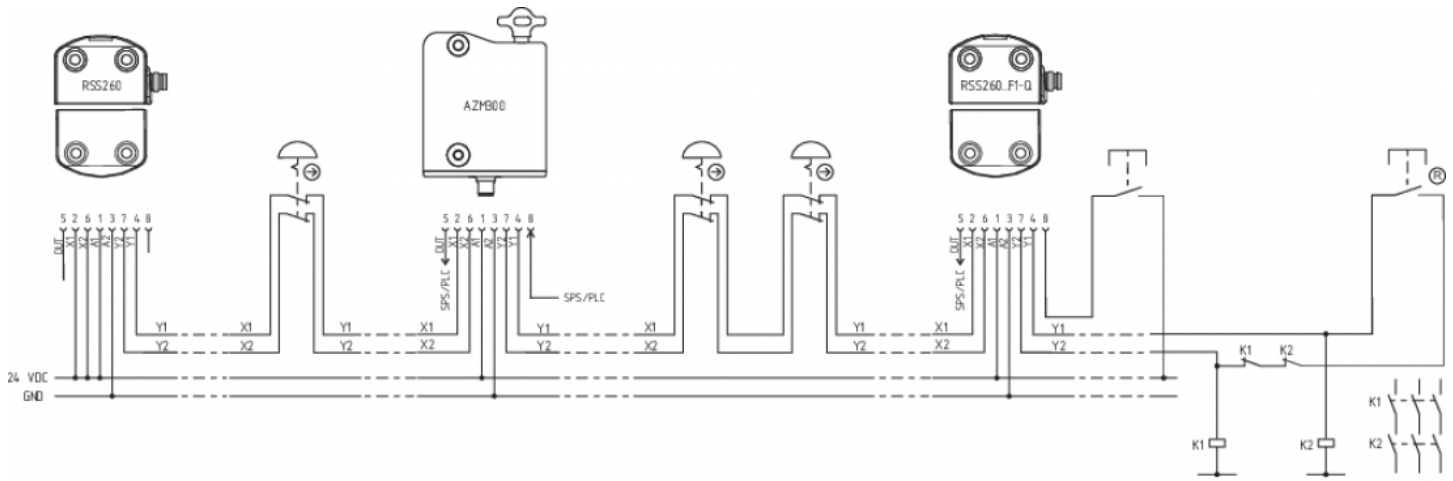

5.4 Wiring configuration and connector accessories

- for sensor versions with integrated connection cable or 8-pin plug M8/M12, A-coded

Function safety switchgear			Pin assignment of the installation-resp. connector plug M8/M12, 8-pin, A-coded	Colour code of the integrated cable or the Schmersal connector plug	Poss. Colour codes of other customary connector plugs
	with conventional diagnostic output	with serial diagnostic function		to DIN 47100	to EN 60947-5-2
A1	Ue		1	WH	BN
X1	Safety input 1		2	BN	WH
A2	GND		3	GN	BU
Y1	Safety output 1		4	YE	BK
OUT	Diagnostic output	SD output	5	GY	GY
X2	Safety input 2		6	PK	PK
Y2	Safety output 2		7	BU	VT
IN	without function / with Q option: error acknowledgement	SD input	8	RD	OR

- For sensor versions with 5-pin connector, M12, A-coded

Function safety switchgear			Pin assignment of connector plug M12, 5-pin, A-coded	Colour code of the integrated cable or the Schmersal connector plug	Poss. Colour code of other commercially available connector plugs according to EN 60947-5-2
					
A1	Ue		1		BN
Y2	Safety output 2		2		WH
A2	GND		3		BU
Y1	Safety output 1		4		BK
OUT	-	Diagnostic output	5	For internal purposes only, external signals are ignored	GY

Connecting cables (PUR) with coupling (female), IP67, M8, 8-pin, 8 x 0.25 mm ² , straight	
Cable length	Ordering code
2 m	103043259
5 m	103043260
10 m	103043261
15 m	103043262

Connecting cables (PUR) with coupling (female), IP67, M8, 8-polig, 8 x 0.25 mm ² , angled	
Cable length	Ordering code
2 m	103043263
5 m	103043264
10 m	103043265

Connection adapter (PUR) M8 coupling M12 connector, IP67, 8-pole, 8 x 0.25 mm ²	
Cable length	Ordering code
2 m	103003645

Connecting cables (PUR) with coupling (female), IP67 / IP69, M12, 5-pin, 5 x 0.34 mm ² , straight	
Cable length	Ordering code
5 m	103010816
10 m	103010818
15 m	103010820

6 Actuator coding

Safety sensors with standard coding are ready to use upon delivery.

Individually coded safety sensors and actuators will require the following "teach-in" procedure:

1. Energise the safety sensor.
2. Introduce the actuator in the detection range. The teach-in procedure is signalled at the safety sensor, red LED on, yellow LED flashes (1 Hz).
3. After 10 seconds, brief yellow cyclic flashes (3 Hz) request the switch-off of the operating voltage of the safety sensor. (If the voltage is not switched off within 5 minutes, the safety sensor cancels the "teach-in" procedure and signals a false actuator by 5 red flashes.)
4. Once the operating voltage is switched back on, the actuator must be detected once more in order to activate the actuator code that has been taught in. In this way, the activated code is definitively saved.

For ordering suffix -I1, the executed allocation of safety switchgear and actuator is irreversible.

For ordering suffix -I2, the "teach-in" procedure for a new actuator can be repeated an unlimited number of times. When a new actuator is taught, the code, which was applicable until that moment, becomes invalid. Subsequent to that, an enabling inhibit will be active for ten minutes, thus providing for an increased protection against tampering. The green LED will flash until the expiration of the time of the enabling inhibit and the detection of the new actuator. In case of power failure during the lapse of time, the 10-minutes tampering protection time will restart.

7 Working principle and diagnostic function

7.1 Mode of operation of the safety outputs

The safety outputs can be integrated into the safety circuit of the control system.

The opening of a safety guard, i.e. the actuator is removed out of the active zone of the sensor, will immediately disable the safety outputs of the sensor.

7.2 Diagnostic-LEDs

The safety sensor indicates the operating condition and faults by means of three-colour LEDs located in the lateral surfaces of the sensor.



The following LED indicators are the same for safety sensors with conventional diagnostic output as for those with a serial diagnostic function.

The green LED indicates that the safety sensor is ready for operation. The supply voltage is on and all safety inputs are present.

Flashing (1Hz) of the green LED signals that a voltage is missing on one or both of the safety inputs (X1 and/or X2).

The yellow LED always signals the presence of an actuator within range. If the actuator is operating in the limit area of the sensor switching distance, it will be indicated by flashing.

The flashing can be used to prematurely detect variations in the clearance between the sensor and the actuator (e.g. sagging of a safety guard). The sensor must be adjusted before the distance to the actuator increases and before the safety outputs are disabled, thus stopping the machine. If an error is detected, the red LED will be activated.

LED indication (red)		Error cause
1 flash pulse		Error output Y1
2 flash pulses		Error output Y2
3 flash pulses		Cross-wire Y1/Y2
4 flash pulses		Ambient temperature too high
5 flash pulses		Incorrect or defective actuator
6 flash pulses		Discrepancy time error at X1/X2
Continuous red		Internal fault, with yellow flashing teaching procedure

7.3 Operating principle of the electronic diagnostic output

A diagnostic output additionally indicates the switching condition of the safety switchgear. These signals can be used in a downstream control.

The short-circuit proof diagnostic output OUT can be used for central visualisation or control tasks, e.g. in a PLC.

The diagnostic output is not a safety-related output.

Error

Errors which no longer guarantee the function of the safety switchgear (internal errors) cause the safety outputs to be disabled within the duration of risk. After fault rectification, the error message is reset by opening and re-closing the corresponding safety guard.

A discrepancy time error is saved protected against power interruption and must be reset with an error acknowledgement.

Error warning

A fault that does not immediately endanger the safety function of the safety switchgear (e.g. too high ambient temperature, safety output at external potential, cross-circuit) leads to delayed shutdown. This signal combination, diagnostic output disabled and safety channels still enabled, can be used to stop the production process in a controlled manner.

An error warning is deleted when the cause of error is eliminated.

If the fault warning remains on for 30 minutes, the safety outputs are also switched off (red LED flashes).

Table 1: Examples of the diagnostic function of the safety-sensor with conventional diagnostic output

Sensor function		LED's			Diagnostic output	Safety outputs	Comments
		green	red	yellow			
I.	Supply voltage	On	Off	Off	0 V	0 V	Voltage on, no evaluation of the voltage quality
II.	Actuated	Off	Off	On	24 V	24 V	The yellow LED always signals the presence of an actuator within range.
III.	Actuated, actuator in limit area	Off	Off	Flashes	24 V (pulsed)	24 V	The sensor must be adjusted before the distance to the actuator increases and before the safety outputs are disabled, thus stopping the machine. flashing frequency 1 Hz
IV.	Internal error or in the event of simultaneous flashing, teach-in process	On	Off	Flashes	24 V	0 V	The sensor awaits a signal on the feedback circuit: F0: Closure of the feedback circuit F1: Falling edge on the feedback circuit Flashing frequency 5 Hz
V.	Actuated in limit area and feedback circuit open	On	Off	Flashes	24 V (pulsed)	0 V	LED indication combines the sensor functions III. and IV. flashing frequency: alternately (1 Hz/5 Hz)
VI.	Error warning, sensor actuated	Off	Flashes	On	0 V	24 V	After 30 minutes if the error is not rectified

VII.	Error	Off	Flashes	On	0 V	0 V	Refer to table with flash codes
VIII.	Teach actuator	Off	On	Flashes	0 V	0 V	Sensor in teaching mode
IX.	Protection time	Flashes	Off	Off	0 V	0 V	10 minutes pause after re-teaching
X.	Error in input circuit X1 and/or X2	Flashes (1Hz)	Off	Off	0 V	0 V	Example: door open; a door in the safety circuit upstream is also open.
XI.	Error in input circuit X1 and/or X2	Flashes (1Hz)	Off	On	24 V	0 V	Example: door closed, a door in the safety circuit upstream is open.

7.4 Safety-sensors with serial diagnostic function

Safety sensors with serial diagnostic cable have a serial input and output instead of the conventional diagnostic output. If RSS / CSS safety sensors are wired in series, the safety channels as well as the inputs and outputs of the diagnostic channels are wired in series.

Up to 31 safety switchgear devices can be connected in series with serial diagnostics. For the evaluation of the serial diagnostics line either the PROFIBUS-Gateway SD-I-DP-V0-2 or the Universal-Gateway SD-I-U... are used. This SD-Gateway is integrated as a slave in an existing field bus system. In this way, the diagnostic signals can be evaluated by means of a PLC. The necessary software for the integration of the SD-Gateway is available for download at products.schmersal.com.

The response data and the diagnostic data are automatically and permanently written in the assigned input byte of the PLC for each safety sensor in the series-wired chain.

The request data for each safety sensor are transmitted to the device through an output byte of the PLC.

In the event of a communication error between the SD-Gateway and the safety sensor, the switching condition of the safety output of the safety sensor is maintained.

Bit 0: safety outputs enabled

Bit 1: safety sensor actuated, actuator identified

Bit 3: feedback circuit open or reset button not actuated

Bit 4: both safety inputs live

Bit 5: safety sensor actuated in hysteresis area

Bit 6: error warning, switch-off delay activated

Bit 7: error, safety outputs switched off

Error

Errors which no longer guarantee the function of the safety switchgear (internal errors) cause the safety outputs to be disabled within the duration of risk. The fault is reset, when the cause is eliminated and bit 7 of the request byte changes from 1 to 0 or the safety guard is opened. Faults at the safety outputs are only deleted upon the next release,

as the fault rectification cannot be detected sooner.

Discrepancy error reset if bit 6 of the call byte changes from 1 to 0.

Error warning

A fault that does not immediately endanger the safety function of the safety switchgear (e.g. too high ambient temperature, safety output at external potential, cross-circuit) leads to delayed shutdown. This signal combination, diagnostic output disabled and safety channels still enabled, can be used to stop the production process in a controlled manner.

An error warning is deleted when the cause of error is eliminated.

If the fault warning remains on for 30 minutes, the safety outputs are also switched off (red LED flashes).

Diagnostic error (warning)

If an error (warning) is signalled in the response byte, detailed fault information can be read out.

Table 2: Function of the visual diagnostic LEDs, the serial status signals and the safety outputs by means of an example

System condition	LED's			Safety outputs Y1, Y2	Status signals serial diagnostic byte Bit n°							
	green	red	yellow		7	6	5	4	3	2	1	0
Non-actuated, inputs X1 and X2 enabled	On	Off	Off	0 V	0	0	0	1	0	0	0	0
Actuated, feedback circuit open / not actuated	On	Off	Flashes (5Hz)	0 V	0	0	0	1	1	0	1	0
Actuated, safety outputs enabled	Off	Off	On	24 V	0	0	0	1	0	0	1	1
Actuated in limit area	Off	Off	Flashes (1Hz)	24 V	0	0	1	1	0	0	1	1
Actuated, warning	Off	On/flash es	On	24 V	0	1	0	1	0	0	1	1
Actuated, fault	Off	On/flash es	On	0 V	1	1	0	1	0	0	1	0

The shown bit order of the diagnostic byte is an example. A different combination of the operational conditions will lead to a change of the bit order.

Table 3: Tabular overview of status signals, warnings or error messages
 (The described condition is reached, when Bit = 1)

Communication directions:	Request byte:	from the PLC to the local safety sensor		
	Response byte:	from the local safety sensor to the PLC		
	Warning/error byte:	from the local safety sensor to the PLC		
Bit n°	Request byte	Response byte	Diagnostic	
			Error warning	Error messages
Bit 0:	---	Safety output activated	Error output Y1	Error output Y1
Bit 1:	---	Actuator detected	Error output Y2	Error output Y2
Bit 2:	---	---	Cross-wire Y1/Y2	Cross-wire Y1/Y2
Bit 3:	---	---	Temperature too high	Temperature too high
Bit 4:	---	Input condition X1 and X2	---	Incorrect or defective actuator
Bit 5:	---	Actuated in limit area	Internal device error	Internal device error
Bit 6:	Error acknowledgement, Discrepancy time exceeded	Error warning	Communication error between the field bus Gateway and the safety switchgear	Error, discrepancy time exceeded at X1/X2
Bit 7:	Error reset	Error (enabling path switched off)	---	---

8 Set-up and maintenance

The safety function of the safety components must be tested. In the case of correct installation and adequate use, the safety switchgear features maintenance-free functionality. A regular visual inspection and functional test, including the following steps, is recommended:

1. Check fixation of the safety switch and the actuator.
2. Fitting and integrity of the cable connections.
3. The system is free of dirt and soiling (in particular metal chips).

Functional test after assembly and connection of the RSS260...-F0/-F1

All safety guards must be closed prior to the start of the functional test. The feedback circuit must be opened. ¹⁾

No.	Action to test the operation	Reaction RSS260 F0 version	Reaction RSS260 F1 version
1	Switch on the operating voltage	The yellow LED flashes at 5 Hz and the relays are disabled.	The yellow LED flashes at 5 Hz and the relays are disabled.
2	Close the feedback circuit: actuate the connected button ²⁾	The yellow LED is on and both connected relays are enabled	No change compared to 1
3	Only version F1: reset button actuation	No change compared to 2	The yellow LED is on and both connected relays are enabled

¹⁾ If no button is used, the feedback circuit must be opened by loosening the cable. To that effect, the voltage must be switched off.

²⁾ If no button is used, the feedback circuit must be closed by reconnecting the cable. To that effect, the voltage must be switched off.

With the F1 function, the button monitored on the falling edge must be actuated.

A non-monitored button integrated into the feedback circuit with function F0 is effective on closing.

An emergency-stop switching element integrated into series wiring can be monitored by the Q function in the last sensor of the chain. This monitors the simultaneous shutdown of its safety inputs and closes the safety outputs in the event of deviations greater than 500 ms. A malfunction in the chain detected in this way must be rectified immediately. Release is only then possible after the error has been acknowledged. The error will remain saved even in the event of a power interruption. Error acknowledgement must be effected via the negative edge of an acknowledge button connected to pin 8 or via the serial diagnosis line.

In addition, when emergency-stop switching elements are integrated, a reset button must be provided, as no automatic restart of the machine is permissible when an emergency-stop command is revoked.

As per the test interval referenced in the Maintenance chapter, the emergency-stop switching elements monitored in this way meet the requirements to PL e.



Adequate measures must be taken to ensure protection against tampering either to prevent tampering of the safety guard, for instance by means of replacement actuators.



EMERGENCY STOP switching elements integrated into a series circuit with Q monitoring must have their function checked manually on a regular basis. An annual inspection is sufficient for a typical Cat. 3/PLd application. A monthly inspection is required for a typical Cat. 4/PLe application.



Damaged or defective components must be replaced.

9 Disassembly and disposal

9.1 Disassembly

The safety switchgear must be disassembled in a de-energised condition only.

9.2 Disposal



The safety switchgear must be disposed of in an appropriate manner in accordance with the national prescriptions and legislations.