

# 取扱いおよび設置説明書

## 電磁ロック付きインターロック AZM201Z-ST-T-1P2PW-2965-2

### Table of Contents

- 1 この文書について
  - 1.1 機能
  - 1.2 対象：権限 資格のある人向け
  - 1.3 使用記号の説明
  - 1.4 適切な使用
  - 1.5 安全上のご注意
- 2 製品内容
  - 2.1 型番
  - 2.2 特殊仕様
  - 2.3 目的
  - 2.4 誤使用に関する警告
  - 2.5 免責事項
  - 2.6 技術データ
- 3 取り付け
  - 3.1 通常取り付け方法
  - 3.2 外形図
- 4 電気配線
  - 4.1 電気配線上的ご注意
  - 4.3 シリアル診断 -SD
  - 4.4 直列配線の配線例
- 5 アクチュエータのティーチング / アクチュエータ検出
- 6 動作原理と診断機能
  - 6.1 ソレノイド制御
  - 6.2 バージョン毎の安全出力の動作
  - 6.3 診断用LED
  - 6.4 診断出力・電磁ロック付きインターロック
  - 6.5 直列診断機能SD付き電磁ロック付きインターロック
- 7 セットアップとメンテナンス
- 8 取り外し・廃棄
  - 8.1 取り外し
  - 8.2 廃棄処分
- 9 付録 - 特殊仕様

## 1 この文書について

### 1.1 機能

本書は、本製品の安全な操作と解体のために、取付け、セットアップ、試運転に必要なすべての情報を提供します。取扱説明書は、完全な

### 1.2 対象：権限 資格のある人向け

この取扱説明書に記述された全ての操作は、使用者によって認められた専門技術者が行ってください。

この取扱説明書を熟読し、コンポーネントの据付及び運転の前に、労働安全及び事故予防のための適用可能な全規定に付いてご確認ください。

機械製造者は、準拠すべき整合規格や、部品の選択、取り付け、インテグレーションに関するその他の技術仕様を慎重に選択する必要があります。

仕様などの記載内容について予告なく変更する事があります。あらかじめご了承ください。

## 1.3 使用記号の説明



情報、助言、注釈：この表示は役立つ追加情報を示します。



注意：取り扱いを誤った場合に、故障、機能不良が想定される内容を示しています。

警告：取り扱いを誤った場合に、傷害を負う可能性が想定される内容、及び物的損害の発生が想定される内容を示しています。

## 1.4 適切な使用

シュメアザールが提供する製品は、個人消費者向けではありません。

本製品は、設備や機械の一部として安全関連機能を果たすために開発されたものです。  
機械や設備全体が正しく機能することを保証することは、機械や設備の製造者の責任です。

セーフティスイッチは下記に挙げられたバージョン、又は製造者によって許可されたアプリケーションに対してのみ使用しなければなりません。

## 1.5 安全上のご注意

ユーザーはこの取扱説明書に記載されている、安全上の説明、各国の設置基準、並びに全ての周知の安全規則や事故防止規則を遵守しなければなりません。



詳細な技術情報についてはSchmersalカタログ、又はインターネット（products.schmersal.com）上のオンラインカタログをご参照下さい。

# 2 製品内容

## 2.1 型番

製品タイプの説明：

AZM201 (1) - (2) - (3) - T - (4) - (5)

(1)

Z	インターロック監視
B	アクチュエーター監視

(2)

なし	標準コード化
I1	個別コード化
I2	個別コード化 複数のティーチング

(3)

SK	ネジ端子
CC	ケーシクランプ式
ST2	コネクタ-M12, 8芯

(4)	
1P2PW	PNPタイプ診断出力1回路、>PNPタイプ安全出力2回路(組み合わせされた診断信号: ガードシステム閉、インターロック起動)
SD2P	シリアル診断出力及び2 PNP安全出力

(5)	
なし	スプリングロック
A	マグネツトロック

アクチュエータ	以下に適用します
AZ/AZM201-B1-...	スライド式ガード
AZ/AZM201-B30-...	ヒンジ式ガード
AZ/AZM201-B40-...	折り重ね式ヒンジドア

## 2.2 特殊仕様

型式記号で挙げられていない特別仕様は一般使用に準じます。



特別な情報、または特別バージョンに関する標準から逸脱した情報は、最後の章「付録 - 特別バージョン」に記載されています。

## 2.3 目的

非接触式セーフティスイッチは、安全回路での用途向けに設計されており、可動ガードの位置やロック状態の監視に使用されます。



セーフティスイッチは、EN ISO 14119に基づきタイプ4のインターロック機器に分類されます。個別コード化の仕様ではコード化レベルHighに分類されます。

電磁ロック機能及びインターロック機能付きのセーフティスイッチとして種々のタイプを使用できます。



リスク分析の結果、監視されたインターロックの使用が必要とされる場合は、のシンボル付きで表示されるインターロック監視タイプの製品を使用してください。アクチュエータ監視機種 (B) は工程保護のためのインターロック機能を持つセーフティスイッチです。

安全機能により、ガードが開いていると安全出力はOFFとなり、ガードが開いている間はOFFの状態を維持します。



マグネツトロックタイプは、電源が故障したりメインスイッチが切れたりするとロックが解除されるため、事故の危険を十分に評価した後の特殊なケ...

### 直列接続

直列接続ができます。直列接続の場合、リスク時間は変わらず、反応時間は、技術データで指定された追加ユニットごとの入力への反応時間0.31のデバイスバリエーションを直列に配線できます。



使用者は、関連規格と要求される安全レベルに基づいてセーフティチェーンを評価し、設計しなければなりません。複数のセーフティセンサーがある場...



セーフティコンポーネントが組み込まれた制御システムの全体的な構想は、関連規格に対して妥当性を確認しなければなりません。

## 2.4 誤使用に関する警告



本製品の不十分、不適切な使用及び無効化の際は、人への危険、機械、設備への損害を負う可能性があります。取付、据付、操作及び保全に関する説

## 2.5 免責事項

誤った取り付けやこの取扱説明書を正しく理解していないために起こった損害、故障は、Schmersalの免責事項となります。また、製造者に安全上の理由から、デバイスに対する独自の変更や不適切な修理、部品の交換や改造は厳として認められず、それが理由で発生した故障や事

## 2.6 技術データ

### 認証

証明書	TÜV cULus FCC IC UKCA ANATEL
-----	---

### 一般データ

規格	EN ISO 13849-1 EN ISO 14119 EN IEC 60947-5-3 EN IEC 61508
一般情報	ユニバーサルコード化
Coding level according to EN ISO 14119	Low
アクティブ原理	RFID
周波数帯、RFID	125 kHz
送信機出力 RFID、最大	-6 dB/m
ハウジング 材質	グラスファイバー強化熱可塑性樹脂
リスク持続時間、最大	200 ms
アクチュエーターの応答時間、最大	100 ms
入力の応答時間、最大	1.5 ms
総重量	619 g

### 一般データ - 仕様

スプリングロック	Yes
ガードロック監視	Yes
手動解除	Yes
短絡検出	Yes
短絡監視	Yes
アイドル割り当て可能押しボタン	Yes
自由に割り当て可能なLED	Yes

安全機能	Yes
一体型システム診断、状態	Yes
安全接点数	2

## 安全性評価

規格	EN ISO 13849-1 EN IEC 61508
----	--------------------------------

### 安全性評価 - インターロック

Performance Level, up to	e
カテゴリ	4
PFH値	$1.90 \times 10^{-9}$ /h
PFD値	$1.60 \times 10^{-4}$
安全インテグリティレベル (SIL), 安全度水準に適合	3
Mission time	20 年

### 安全性評価 - ガードロック

Performance Level, up to	d
カテゴリ	2
PFH値	$1.00 \times 10^{-8}$ /h
PFD値	$8.90 \times 10^{-4}$
Safety Integrity Level (SIL), suitable for applications in	2
Mission time	20 年

## 機械的データ

機械的寿命、最小	1,000,000 操作
EN ISO 14119 に準拠したクロック時引抜強度	2,000 N
注意 (クランプ力 $F_{Zh}$ )	アクチュエーターAZ/AZM201-B30を使用した時1000 N、扉の内部に使用した時
ロック時引抜強度、最大	2,600 N
注意 (クランプ力 $F_{max}$ )	アクチュエーターAZ/AZM201-B30を使用した時1300 N、扉の内部に使用した時
ラッチ力	30 N
作動速度、最大	0.2 m/s
Type of the fixing screws	2x M6
Tightening torque of the fixing screws, maximum	8 Nm
ハウジングカバー用固定ネジの締め付けトルク、最小	0.7 Nm
ハウジングカバー用固定ネジの締め付けトルク、最大	1 Nm
注記	Torx T10

### 機械的データ - 電気機械式

センサーチェーンの長さ、最大	200 m
注意(センサーチェーンの長)	ケーブル長とケーブル径により、出力電流による電圧降下が変化します。

注意 (直列接続)

無制限のデバイス数, 外部ラインヒューズオーバーサーブ、シリアル診断SDの場合、最大

端子 コネクター

M23コネクター, 8+1芯

## 機械的データ - 寸法

センサー長	50 mm
センサーの幅	40 mm
センサーの高さ	220 mm

## 環境条件

保護等級	IP66 IP67
使用周囲温度	-25 ... +60 ° C
保管および輸送温度	-25 ... +85 ° C
相対湿度, 最大	93 %
Note (Relative humidity)	non-condensing non-icing
耐振動	10 ~ 150 Hz、振幅 0.35 mm
耐衝撃	30 g / 11 ms
Protection class	III
Permissible installation altitude above sea level, maximum	2,000 m

## 環境条件 - 絶縁値

定格絶縁電圧	32 VDC
定格インパルス耐電圧	0.8 kV
Overvoltage category	III
汚染度	3

## 電気的データ

動作電圧	24 VDC -15 % / +10 %
無負荷供給電流 $I_0$ , 典型的	50 mA
マグネットON時の消費電流 (平均)	200 mA
マグネットON時の消費電流、ピーク	700 mA / 100 ms
定格動作電圧	24 VDC
動作電流	1,200 mA
要求定格短絡電流	100 A
外部ワイヤとデバイスのヒューズ定格	3A gG
準備時間、最大	4,000 ms
開閉頻度、最大	1 Hz
電気的ヒューズ定格、最大	3 A

## 電気的データ - ソレノイド制御

Designation, Magnet control	IN
-----------------------------	----

マグネット入力のスイッチングの閾値	-3 V ... 5 V (Low) 15 V ... 30 V (High)
24Vの時のマグネット制御の消費電流	10 mA
マグネット起動時間	100 %
テストパルス幅、最大	5 ms
テストパルス間隔、最小	40 ms
Classification ZVEI CB24I, Sink	C0
Classification ZVEI CB24I, Source	C1 C2 C3

## Electrical data – Safety digital inputs

Designation, Safety inputs	X1 and X2
フェイルセーフ入力のスイッチングの閾値	-3 V ... 5 V (Low) 15 V ... 30 V (High)
24Vの時の安全入力の消費電流	5 mA
テストパルス幅、最大	1 ms
テストパルス間隔、最小	100 ms
Classification ZVEI CB24I, Sink	C1
Classification ZVEI CB24I, Source	C1 C2 C3

## Electrical data – Safety digital outputs

Designation, Safety outputs	Y1 and Y2
定格動作電流（安全出力）	250 mA
安全出力	short-circuit proof, p-type
Voltage drop $U_d$ , maximum	2 V
Leakage current $I_r$ , maximum	0.5 mA
Voltage, Utilisation category DC-13	24 VDC
Current, Utilisation category DC-13	0.25 A
テストパルス間隔、標準	1000 ms
テストパルス幅、最大	0.5 ms
Classification ZVEI CB24I, Source	C2
Classification ZVEI CB24I, Sink	C1 C2

## 電氣的データ – 診断出力

Designation, Diagnostic outputs	OUT
動作電流（診断出力）	50 mA
Design of control elements	short-circuit proof, p-type
Voltage drop $U_d$ , maximum	4 V
Voltage, Utilisation category DC-13	24 VDC
Current, Utilisation category DC-13	0.05 A

## 状態表示

Note (LED switching conditions display)

Operating condition: LED green  
Error / functional defect: LED red  
Supply voltage UB: LED green

## ピン配列

PIN 1	A1 Supply voltage UB
PIN 2	キーボタンは+24V-X1-X2へ
PIN 3	A2 GND
PIN 4	Y1 Safety output 1
PIN 5	OUT Diagnostic output
PIN 6	白色LED
PIN 7	Y2 Safety output 2
PIN 8	IN Solenoid control
PIN 9	Not used

## 安全分類について



ガードロック機能の分類は、監視対象の電磁ロック付きインターロックAZM201Z-----1P2PW----

の標準機に対してのみ適用されます(型式記号参照)。 シリアル診断“SD2P”  
付き機器のためのガードロック機能の安全分類は、SDゲートウェイからのロック/ロック解除信号が安全ではないため許可されていません。



特定のアプリケーションで、スプリングロックタイプの電磁ロック付きインターロックが使えない時は、同等のレベルを持つ追加の安全方策が実現出



ガードロック機能の安全性分析において、電磁ロック付きインターロックAZMを完全なシステムの一部として参照しています。  
障害を防止するための、安全な動作や安全な動作やケーブルの保護といった更なる方策は、ユーザー側で行わなければなりません。

ガードロックが解除されるという故障が発生した場合、これは電磁ロック付きインターロックにより検知され、安全ドアのY1/Y2がOFFします。この様



インターロックの作動は、外部へのOSSD出力信号と比較されなければなりません。意図しないロック解除が原因でシャットダウンが発生した場合、こ

## UL 規格

絶縁電源のみを使用してください。NFPA 79

アプリケーションでのみ使用します。フィールド配線の手段を提供するアダプターは、メーカーから入手出来ます。メーカーの情報をご参照

## FCC/IC - 注意

このデバイスは、FCC規則のパート15に準拠しており、またカナダのイノベーション科学経済開発省のライセンス免除RSSIに準拠するライセンス  
操作は、次の2つの条件の下で許可されます：

(1) 本装置は有害な干渉信号を発生させてはならない。

(2) 本装置は干渉信号を許容できなければならない。これらの条件には、本装置が不適切に機能する原因となる干渉信号も含まれます。

本装置は、100mm以上の距離で使用される場合、神経刺激制限 (ISED SPR-

002) に準拠します。K. A. が明示的に承認していない変更または修正。デバイスを使用するユーザの権限を無効にする可能性があります。

この機器に含まれる免許不要の送受信機は、免許不要の無線機器に適用されるカナダ革新 科学

経済開発 (ISED) 当局の「無線規格仕様」の要件を満たしています。この機器に含まれる免許不要の送受信機は、免許不要の無線機器に適用

科学 経済開発 (ISED) 当局の「無線規格仕様」の要件を満たしています。以下の2つの条件下で動作が許可されます：

(1) 妨害電波を発生させてはならない。

(2) 本装置は、その機能を損なう可能性がある場合であっても、受信した無線周波数の干渉を許容しなければならない。

本装置は、100mm以上の距離で使用する場合、神経刺激制限 (ISED CNR-102) に適合します。

Schmersal GmbH & Co. KG が明示的に承認していない変更または改造を行った場合、

ユーザーによるデバイスの使用許可は無効になる場合があります。



## 3 取り付け

### 3.1 通常の取り付け方法



規格ISO 12100、ISO 14119及びISO 14120の関連要求事項を遵守してください。

安全スイッチとアクチュエータを取り付けるために、ワッシャー付きM6ネジ用の2つの取り付け穴が用意されています（ワッシャーは同梱されています）。安全スイッチはストッパーとして使用しないでください。どの設置位置でも設置可能です。アクチュエータ挿入部にゴミやホコリが入らないようにしてください。

#### 2つの安全開閉装置間の最小距離

同じ周波数の他のシステムと同様に（125 kHz）：100 mm.

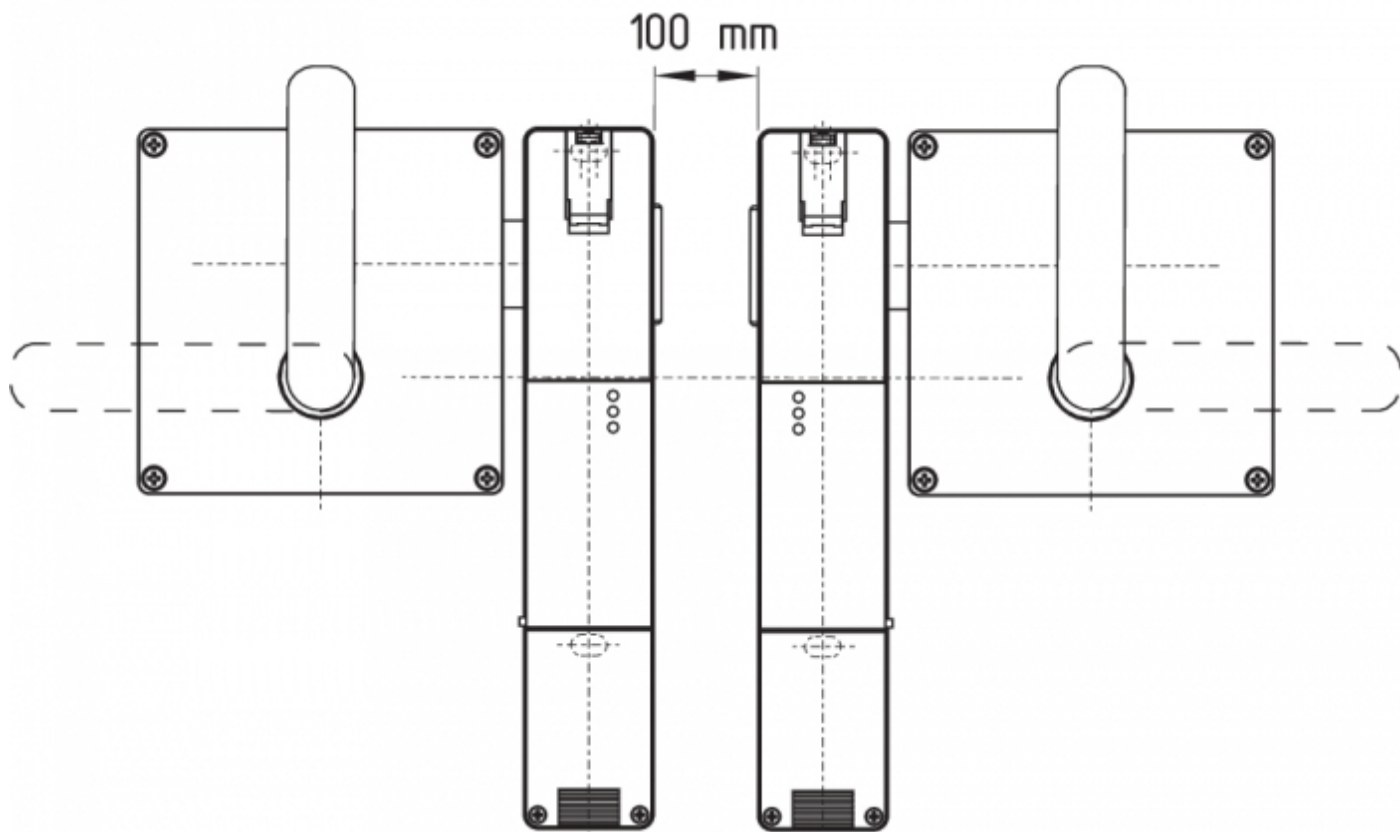

#### アクチュエータの取り付け

適合するアクチュエータの取扱説明書をご参照下さい。



アクチュエータはガードに確実に取り付け、適切な方法（無効化防止ネジ、接着、ネジヘッドをつぶすなど）により取り外しが出来ないようにしなければなりません。

#### マニュアルリリース

機械のセットアップ時に、本製品は非通電でロック解除出来ます。プラスチックのカバー“A”（外形寸法図参照）を開け、三角キーを時計回りに回します。ロック機能を復帰させるには、三角キーを元の位置に戻します。



注意：ラッチ位置を超えて回さないでください、最大トルク値：1.3 Nm.

ロック機能を復帰させたら、プラスチックカバー“A”を閉じ、付属のシールを張り付けてください。

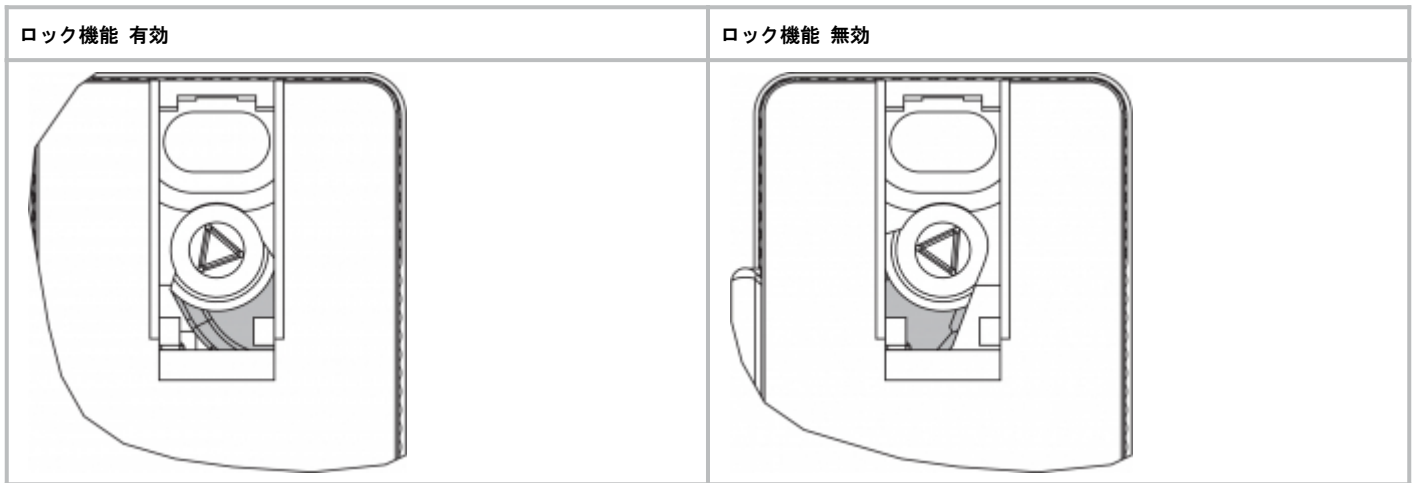

## 3.2 外形図

全ての寸法表記はmm

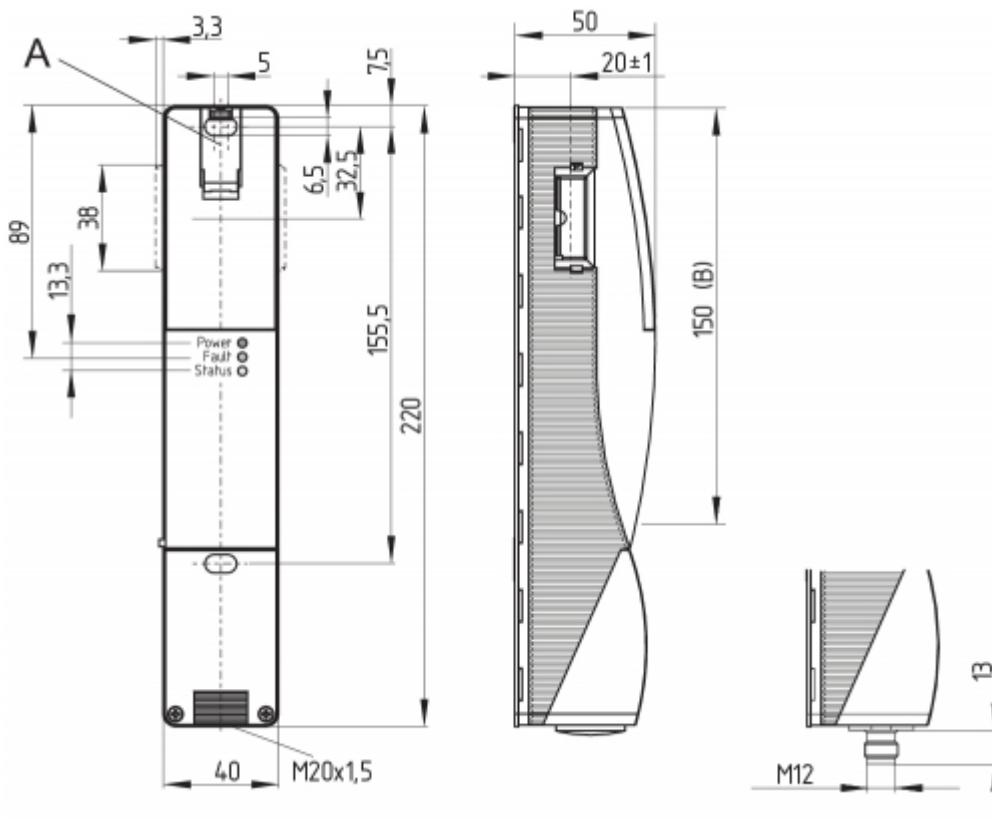

### 凡例

A: マニュアルリリース  
B: アクティブRFIDエリア



安全開閉装置およびアクチュエータの側面 RFID エリアの金属部品と磁場は、開閉距離に影響を与えたり、誤動作を引き起こす可能性があります。

## 手動解除/緊急脱出用改造キット

改造キットは、電磁ロック付きインターロックの後付けの機能拡張に使用します。

	型式	品番
緊急解除	RF-AZM200-N	103003543
緊急脱出	RF-AZM200-T	103004966

## 4 電気配線

### 4.1 電気配線上のご注意



電気配線は専門技術者が非通電の状態で行って下さい。

電源には永続的な過電圧に対する保護が必要です。EN 60204-1に基づく電源ユニットを推奨します。

必要なケーブルのヒューズ保護を設置時に統合する必要があります。

安全出力は制御システムの安全回路に接続出来ます。

#### 接続するセーフティリレーユニットの要求事項:

2チャンネル安全入力で2つのPNPタイプの半導体出力に適します。



#### セーフティコントローラの構成

安全開閉装置が電子安全監視モジュールに接続されている場合は、少なくとも 100 ミリ秒の不一致時間を設定することをお勧めします。安全監視モジュールの安全入力は、約 100 秒のテスト インパルスをブランキングできなければなりません。1ミリ秒安全監視モジュールはクロスワイヤショート監視機能を持つ必要はありませんが、必要に応じてクロスワイヤショート監視機能を無効にする必要があ



適切なセーフティリレーユニットの選択に関する情報は、Schmersalのカatalogか、インターネット (products.schmersal.com) 上にあるオンラインカタログをご覧ください。

#### ケーブル

ケーブル引込口には M20

のケーブルグランドを使用します。このケーブルグランドは、使用するケーブルに合わせてユーザーが寸法決めをしなければなりません。リリーフと適切な IP 保護等級を備えたケーブル グランドを使用する必要があります。

#### 導体長さxの設定:

- ネジ端子の場合 (SK): 8 mm
- タイプs、rまたはfのケージクランプ (CC) の場合: 7.5 mm

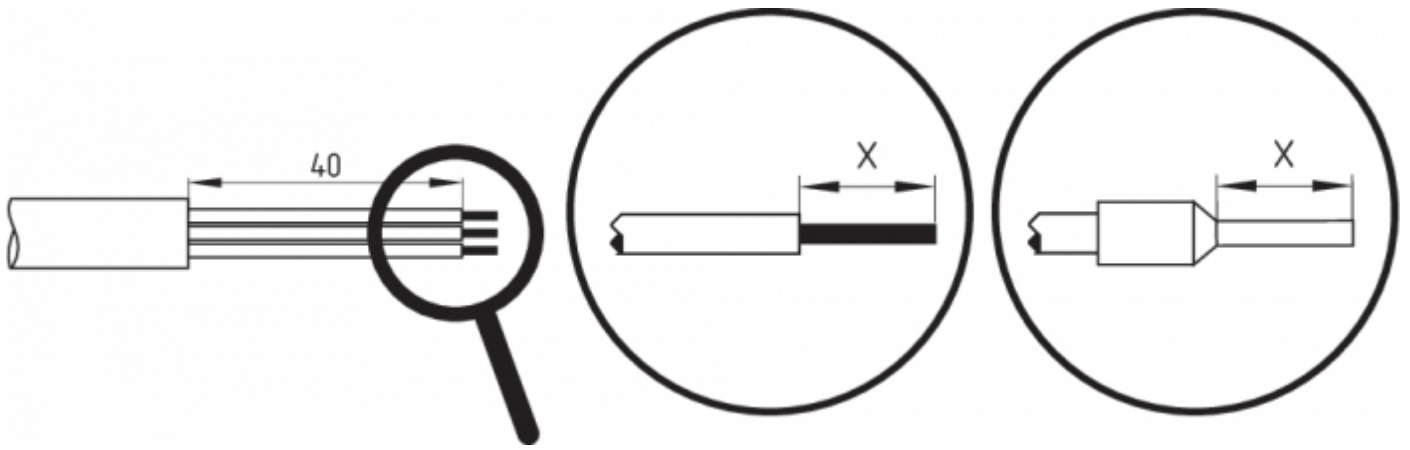

### 4.3 シリアル診断 -SD



24V用 X1, X2 のブリッジは-1P2PW 及び …-SD2Pでは出荷時にセットされています。



SD機器に配線する時には、ケーブルによる電圧降下や個々のコンポーネントの電流容量に配慮してください。



#### 直列接続のオプション

SDコンポーネントを便利に直列接続するために、追加のアクセサリとして、SD接続箱PFB-SD-4M12-SD（屋外用）とPDM-SD-4CC-SD（制御盤用）が用意されています。詳しくはインターネット（[products.schmersal.com](http://products.schmersal.com)）をご覧ください。

### 4.4 直列配線の配線例

直列配線が可能です。直列接続の場合、リスク時間は変わらず、反応時間は、技術データで指定された追加ユニットごとの入力への反応時間の合計です。… SDを直列診断付きで31個まで直列接続する事が可能です。

アプリケーション例を提示します。個々のアプリケーションに対して、スイッチ類やそのセットアップが適切かどうか、注意深くチェックしてください。

#### 配線例1：AZM201と従来の診断出力を直列配線します。

直列配線では、最後のコンポーネントまでのすべてのコンポーネントから 24V-X1-X2

ブリッジを削除する必要があります。電源は接続されたセーフティスイッチの最終（リレーユニットを基準として）で両方の安全入力にイン

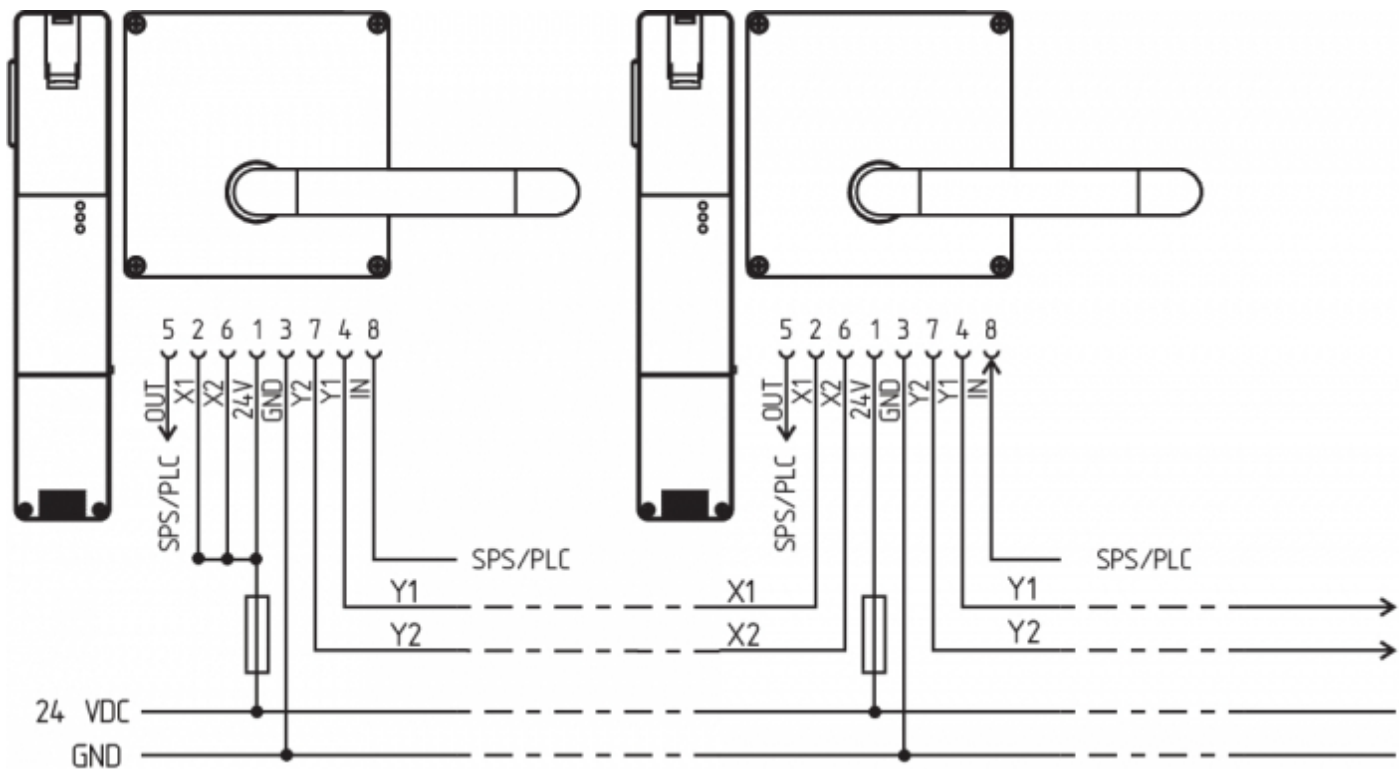

Y1 と Y2 = 安全出力 → 安全リレーユニット

**配線例2：シリアル診断機能付きAZM201の直列配線（最大31台直列）**

シリアル診断機能（順序接尾辞 -SD）を備えたデバイスでは、シリアル診断接続が直列に配線され、評価目的で SD ゲートウェイに接続されます。最初のセーフティコンポーネントの安全出力は、セーフティリレーユニットに接続されます。シリアル診断

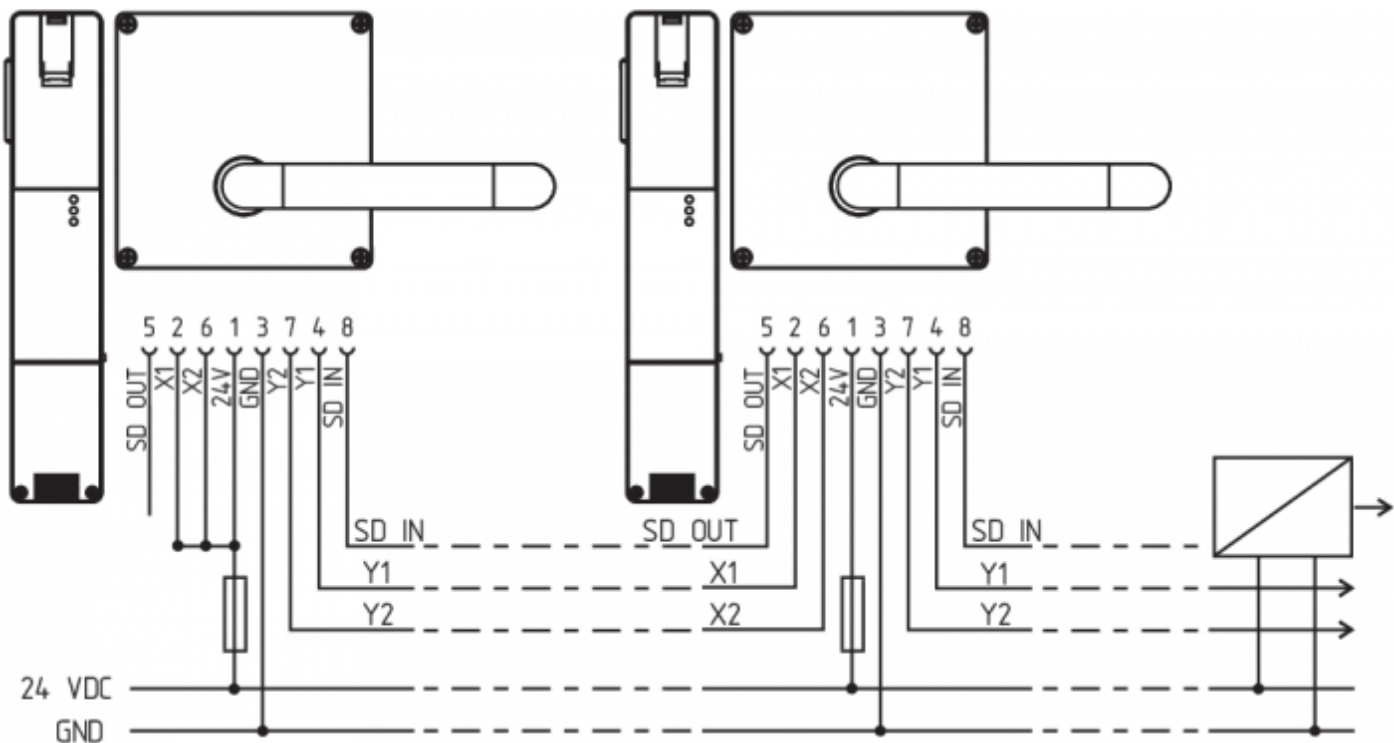

Y1 と Y2 = 安全出力 → 安全リレーユニット

SD-IN ゲートウェイ フィールドバス

接続・コネクタピン配列

セーフティスイッチの機能		ST2, M12, 8-極 コネクタのピン配 列	脱着式端子台の 構成	DIN 47100に基づくシュ メアザールコネク タのカラーコード	EN 60947-5- 21に基づく市販のコ ネクタのカラーコ ード	
	従来型診断機能付 き	シリアル診断機能 付き				
24V	Ue		1	1	白	茶
X1	安全入力 1		2	2	茶	白
GND	GND		3	5	緑	青
Y1	安全出力 1		4	7	黄	黒
OUT	診断出力	SD 出力	5	9	灰	灰
X2	安全入力 2		6	3	ピンク	ピンク
Y2	安全出力 2		7	8	青	紫
IN	ソレノイド制御	SD入力	8	4	赤	橙
	機能なし		-	6		

配列 注文用端子台 サフィックス -SK または -CC	配列取り外し可能な端子台付きバージョン																														
<table border="1"> <tr><td>24V</td><td>24V</td><td>X1</td><td>X2</td><td>IN</td></tr> <tr><td colspan="5">AZM201.-.-1P2PW-</td></tr> <tr><td>GND</td><td></td><td>Y1</td><td>Y2</td><td>OUT</td></tr> </table>	24V	24V	X1	X2	IN	AZM201.-.-1P2PW-					GND		Y1	Y2	OUT	<table border="1"> <tr><td>24V</td><td>24V</td><td>X1</td><td>X2</td><td>IN</td></tr> <tr><td colspan="5">AZM201.-.-SD2P-</td></tr> <tr><td>GND</td><td></td><td>Y1</td><td>Y2</td><td>OUT</td></tr> </table>	24V	24V	X1	X2	IN	AZM201.-.-SD2P-					GND		Y1	Y2	OUT
24V	24V	X1	X2	IN																											
AZM201.-.-1P2PW-																															
GND		Y1	Y2	OUT																											
24V	24V	X1	X2	IN																											
AZM201.-.-SD2P-																															
GND		Y1	Y2	OUT																											
	<table border="1"> <tr><td>1</td><td>2</td><td>3</td><td>4</td></tr> <tr><td colspan="4">AZM201.-.-1P2PW-</td></tr> <tr><td>5</td><td>6</td><td>7</td><td>8</td><td>9</td></tr> </table>	1	2	3	4	AZM201.-.-1P2PW-				5	6	7	8	9																	
1	2	3	4																												
AZM201.-.-1P2PW-																															
5	6	7	8	9																											

カップリング付き接続ケーブル (メス) IP67 / IP69、M12、8極 - 8 x 0.25 mm <sup>2</sup> 、DIN 47100	
ケーブル長	品番
2.5 m	103011415
5.0 m	103007358
10.0 m	103007359
15.0 m	103011414

## 5 アクチュエータのティーチング / アクチュエータ検出

標準コード化された電磁ロック付きインターロックは納入後直ぐに使用できます。

個別コード化された電磁ロック付きインターロックとアクチュエータは以下のティーチング工程が必要です。

1. 電磁ロック付きインターロックの電源供給を遮断し、再投入してください。
2. アクチュエータを検出領域に導きます。ティーチングの手順が電磁ロック付きインターロックのLED、緑OFF、赤ON、黄色点滅(1 Hz)で示されます。
3. 10秒後に黄色LEDが短い(3 Hz)点滅で、電磁ロック付きインターロックの動作電圧の遮断を要求します。(5分以内に遮断されない場合、電磁ロック付きインターロックの動作電圧が再投入された後、ティーチングされたコードを有効にするために、アクチュエータをもう一度検出する必要があります(製品型式I2にて、新規アクチュエータのティーチング時は下記を参照ください))

suffix -I1の要求により、セーフティスイッチとアクチュエータの組み合わせは変更する事は出来ません。

型式末尾が -

I2の場合、新しいアクチュエータでの「ティーチング」手順は制限なく繰り返す事が出来ます。新規アクチュエータのティーチング時に、

## 6 動作原理と診断機能

### 6.1 ソレノイド制御

AZM201のスプリングロックタイプにおいては、インターロックはIN信号(= 24V)がセットされた時に解除されます。AZM201のマグネットロックタイプにおいては、インターロックはIN信号(= 24V)がセットされた時にロックされます。

### 6.2 バージョン毎の安全出力の動作

標準のAZM201のバージョンでは、ロック解除で安全出力は無効になります。ロック解除されたガードは、アクチュエータがAZM201に挿入された時に安全出力も復帰します。ガードを開く必要はありません。

BバージョンAZM201Bの場合、セーフティガードが開くことで安全出力は無効になります。

### 6.3 診断用LED

電磁ロック付きインターロックの前面には3色のLEDが配され、動作状態やエラーを表示します。

緑 (電源)	動作電圧ON
黄 (状態)	動作状況
赤 (故障)	エラー (表参照2: エラーメッセージ / 赤色診断LEDの点滅コード)

### 6.4 診断出力・電磁ロック付きインターロック

短絡保護のある診断出力は、表示用又はPLCなどの非安全関連制御部に使用可能です。

診断出力は安全性に関連する出力ではありません。

#### エラー

セーフティ スイッチギアの機能を保証できなくなるエラー (内部エラー) により、リスク期間内に安全出力が無効になります。エラーを修復した後、関連するガードを一旦開けて再び閉じると、エラーメッセージが表示されます。



安全出力で複数のエラーが検出された場合、又はY1とY2の間で交差短絡が確認された場合、自動電子ロックが行われます。つまり通常のエラー確認は行われません。

#### エラー警告

安全開閉装置の安全機能を直ちに危険にさらさない障害 (周囲温度が高すぎる、外部電位での安全出力、交差回路など) は、シャットダウン (表参照2を参照)。診断出力が遮断し、安全チャンネルが有効と言うこの組み合わせは、制御された方法で生産プロセスを停止する事に使用されます。30 分間継続すると、安全出力もオフになります (赤色の LED が点滅、表 2 を参照)。

#### 診断出力 (...-IP2PW) の動作

(例: スプリングロックバージョン)

#### 入力信号ソレノイド制御

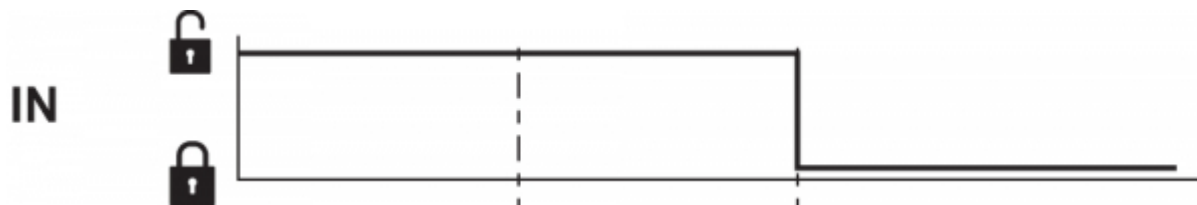

ドアロック時の通常シーケンス



ドアをロック出来ないか故障

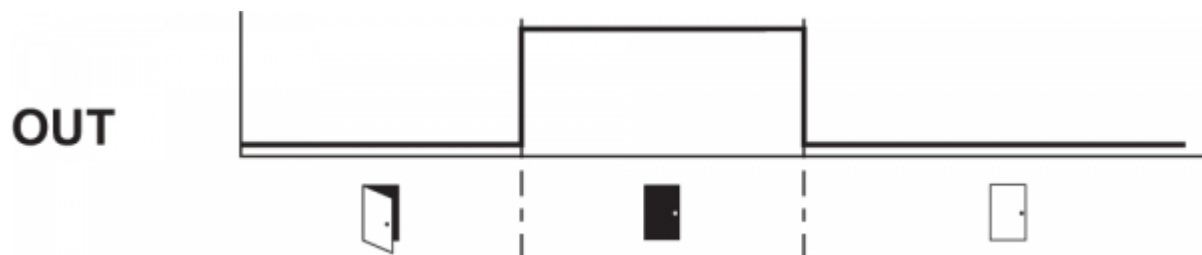

記号説明



ロック



ロック解除



ドアが開いた状態



ガード閉



ロック時間: 150 ... 250 ms, 通常 200 ms



ガードはロックされていないか故障



ガードロック

診断出力(...-1P2PW)の評価



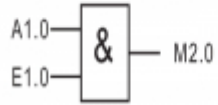
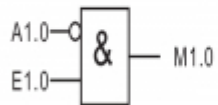
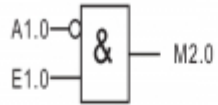
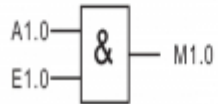
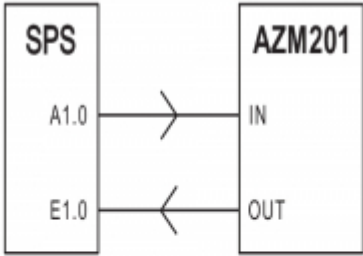

システム状況	ソレノイド制御 IN		LED			安全出力 Y1, Y2		診断出力OUT
	スプリングロック	マグネットロック	緑	赤	黄	AZM201Z	AZM201B	-1P2PW
ドアが開いた状態	24 V (0 V)	0 V (24 V)	0n	Off	Off	0 V	0 V	0 V
ドア閉、アクチュエーター未挿入	24 V	0 V	0n	Off	Off	0 V	0 V	0 V
ドア閉、アクチュエーター挿入、未ロック	24 V	0 V	0n	Off	点滅	0 V	24 V	24 V
ドアが閉じ、アクチュエーターが挿入され、インターロックがブロックされている	0 V	24 V	0n	Off	点滅	0 V	24 V	0 V
ドア閉、アクチュエーター挿入 (ロック)	0 V	24 V	0n	Off	0n	24 V	24 V	24 V
エラー警告 <sup>1)</sup> 電磁ロック付きインターロックのロック	0 V	24 V	0n	点滅 <sup>2)</sup>	0n	24 V <sup>1)</sup>	24 V <sup>1)</sup>	0 V
エラー	0 V (24 V)	24 V (0 V)	0n	点滅 <sup>2)</sup> /Off <sup>1)</sup>	Off	0 V	0 V	0 V
<b>仕様 I1/I2 での追加:</b>								
アクチュエーターの教示行程開始			Off	0n	点滅	0 V	0 V	0 V
I2のみ: アクチュエーターの教示プロセス (ブロック解除)			点滅	Off	Off	0 V	0 V	0 V
<sup>1)</sup> 30分後、安全出力遮断 <sup>2)</sup> 点滅コード参照								

点滅コード (赤)	表示	安全出力がOFFとなるまでの時間	エラーの原因
1回点滅	Y1出力のエラー (警告)	30分	出力遮断時の出力テスト又はY1の電圧異常
2回点滅	Y2出力のエラー (警告)	30分	出力遮断時の出力テスト又はY2の電圧異常
3回点滅	交差短絡エラー (警告)	30分	出力Y1、Y2の交差短絡または両方の出力エラー
4回点滅	温度超過エラー (警告)	30分	内部温度が高い
5回点滅	アクチュエーターのエラ	0分	誤った又は欠陥のあるアクチュエーター
6回点滅	アクチュエーターの組み合わせエラー	0分	誤ったアクチュエーターとの組み合わせ (ブロッキングボルトの検出又は無効化).
赤連続点灯	内部エラー / 過電圧又は低電圧エラー	0分	機器の故障 / 電圧が仕様の範囲にない

## 6.5 直列診断機能SD付き電磁ロック付きインターロック

シリアル診断ケーブル付き電磁ロック付きインターロックには、従来型の診断出力の代わりに、シリアル入出力ケーブルを有しています。

最大31個の電磁ロック付きインターロックが直列に接続出来ます。シリアル診断ラインの評価には PROFIBUSゲートウェイ SD-I-DP-V0-2 又はユニバーサルゲートウェイ SD-I-U-...を使用します。このシリアル診断用インターフェースはスレーブとして既存のフィールドバスシステムに組み込めます。この様にして、診断

SDゲートウェイの接続に関する必要なソフトウェアは、products.schmersal.comからダウンロード出来ます。

応答データと診断データは、直列に接続された個々の電磁ロック付きインターロック用に自動的・継続的にPLCの入力バイトに書き込まれます。

### エラー

セーフティ スイッチギアの機能を保証できなくなるエラー（内部エラー）により、リスク期間内に安全出力が無効になります。原因が排除され故障が発生すると、安全出力は遮断されます。故障からの復帰が直ち



安全出力で複数のエラーが検出された場合、又はY1とY2の間で交差短絡が確認された場合、自動電子ロックが行われます。つまり通常のエラー確認は

### エラー警告

セーフティ スイッチギアの安全機能を直ちに危険にさらさない障害（たとえば、周囲温度が高すぎる、外部電位での安全出力、交差回路）は、シャットダウンの遅延につながります。診断出力が遮断し、安全チャンネルが有効と言うこの組み合わせは、制御された方法で生産プロセスを停止させます。エラー警告は原因が排除された際にリセットされます。障害警告が 30 分間継続すると、安全出力もオフになります（赤色の LED が点滅）。

### 診断エラー（警告）

応答バイトにおいてエラー（警告）が発せられた場合、詳細な情報を読み出す事が出来ます。

表3: I/O データと診断データ  
(Bit = 1の時記述された状態になります)

ビット番号	要求バイト	応答バイト	診断エラー警告	診断エラー
ビット 0:	マグネットロック式、スプリングロック式に関わらず マグネットIN	安全出力動作	Y1出力のエラー	Y1出力のエラー
ビット 1:	---	アクチュエータ検出	Y2出力のエラー	Y2出力のエラー
ビット 2:	---	アクチュエータ検出及びロック	交差短絡	交差短絡
ビット 3:	---	---	温度超過	温度超過
ビット 4:	---	X1 と X2の入力状態	---	誤った又は欠陥のあるアクチュエータ
ビット 5:	---	ガード検出	内部機器エラー	内部機器エラー
ビット 6:	---	エラー警告 <sup>1)</sup>	フィールドバス・ゲートウェイとセーフティスイッチ間の通信エラー	---
ビット 7:	エラーリセット	エラー（安全出力OFF）	動作電圧低過ぎ	---

<sup>1)</sup> 30後 → エラー

## 7 セットアップとメンテナンス

セーフティコンポーネントの安全機能をテストする必要があります。正しく取り付けられ、適切に使用されていれば、セーフティスイッチ

1. セーフティスイッチとアクチュエーターの取り付けチェック
2. アクチュエーターとセーフティスイッチの最大軸ズレをチェック。
3. ケーブルコネクタが確実に取り付けられているか確認
4. ハウジングに損傷がないか確認
5. ゴミや汚れなどを取り除いてください



予備のアクチュエータを使うなどのセーフティガードの改ざんを防止し、無効化から保護するために、適切な方を講じなくてはなりません。



破損、故障の場合は交換してください。

## 8 取り外し・廃棄

### 8.1 取り外し

セーフティスイッチの取り外しは非通電状態で行わなければなりません。

### 8.2 廃棄処分



セーフティスイッチは国家規格や法規に従って、適切な措置により廃棄しなければなりません。

## 9 付録 □ 特殊仕様

スペシャルバージョン -2965-1

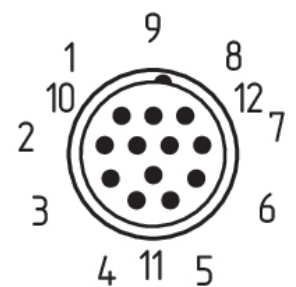
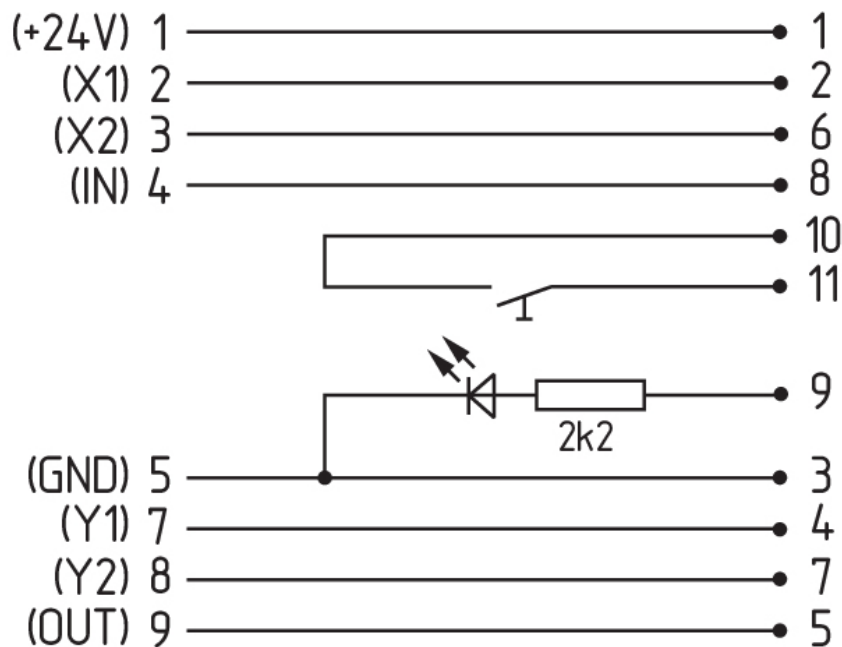

カップリング付き接続ケーブル (メス) IP67, M23, 12極 - 12 x 0.75 mm<sup>2</sup>

ケーブル長	品番
5.0 m	101208520
10.0 m	103007354
20.0 m	101214418

スペシャルバージョン -2965-2

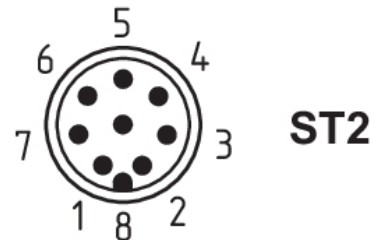
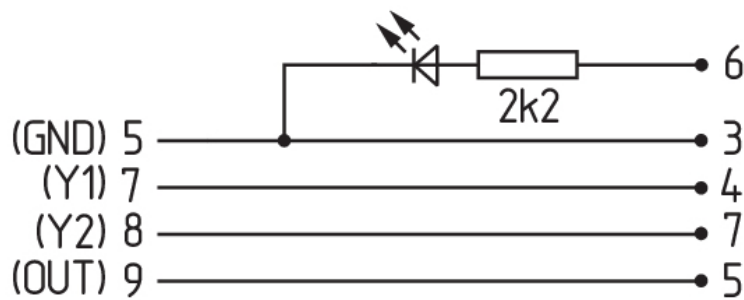
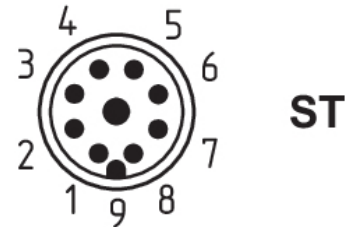
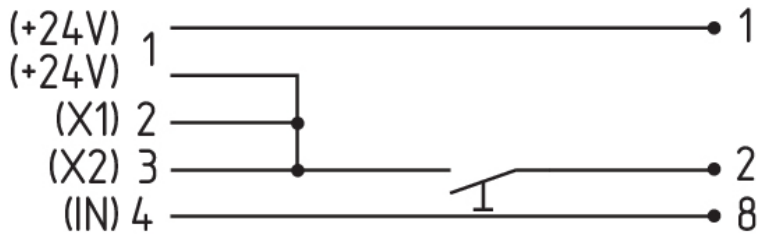

カップリング付き接続ケーブル (メス) IP67, M23, 8+1極 - 9 x 0.75 mm<sup>2</sup>

ケーブル長	品番
5.0 m	101209959
10.0 m	101209958
15.0 m	103001384

カップリング付き接続ケーブル (メス) IP67, M12, 8極 - 8 x 0.25 mm<sup>2</sup>

ケーブル長	品番
2.5 m	103011415
5.0 m	103007358
10.0 m	103007359

スペシャルバージョン -2965-3

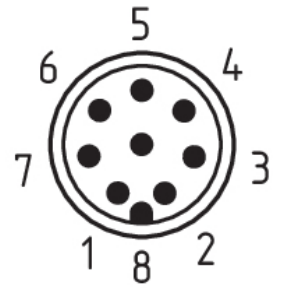
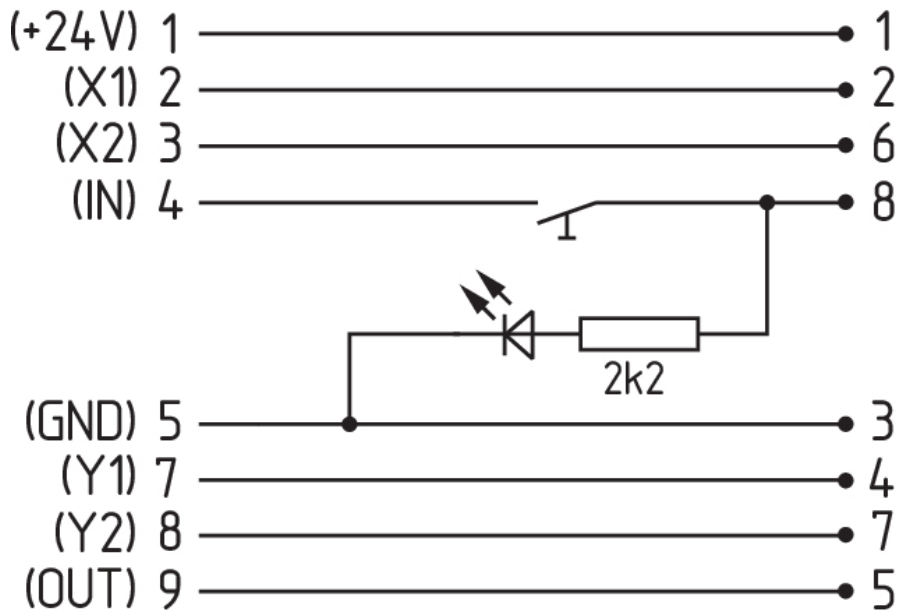

カップリング付き接続ケーブル (メス) IP67, M12, 8極 - 8 x 0.25 mm<sup>2</sup>

ケーブル長

品番

2.5 m

103011415

5.0 m

103007358

10.0 m

103007359