

INSTRUÇÕES DE OPERAÇÃO E MONTAGEM

Encravamento de segurança AZM400Z-ST2-I2-2P2P-E

Conteúdo

- 1 About this document
 - 1.1 Function
 - 1.2 Target group of the operating instructions: authorised qualified personnel
 - 1.3 Explanation of the symbols used
 - 1.4 Appropriate use
 - 1.5 General safety instructions
 - 1.6 Warning about misuse
 - 1.7 Exclusion of liability
- 2 Product description
 - 2.1 Ordering code
 - 2.2 Special versions
 - 2.3 Purpose
 - 2.4 Technical Data
- 3 Mounting
 - 3.1 General mounting instructions
 - 3.2 Manual release
 - 3.3 Electrical manual release - E (for -ST2)
 - 3.4 Emergency exit -T
 - 3.5 Assembly with mounting set
 - 3.6 Dimensions
 - 3.7 Actuator and accessories
- 4 Electrical connection
 - 4.1 General information for electrical connection
 - 4.2 Control options in the normal operating mode
 - 4.3 Requirements for the connected safety-monitoring module
 - 4.4 Wiring configuration and connector accessories
 - 4.5 Wiring examples
- 5 Actuator teaching / actuator detection
- 6 Active principle and diagnostic functions
 - 6.1 Mode of operation of the safety outputs
 - 6.2 Diagnostic-LEDs
 - 6.3 Diagnostic outputs
 - 6.4 Diagnostic information
- 7 Set-up and maintenance
 - 7.1 Functional testing
 - 7.2 Maintenance
- 8 Disassembly and disposal
 - 8.1 Disassembly
 - 8.2 Disposal

1 About this document

1.1 Function

This document provides all the information you need for the mounting, set-up and commissioning to ensure the safe operation and disassembly of the switchgear. The operating instructions enclosed with the device must always be kept in a legible condition and accessible.

1.2 Target group of the operating instructions: authorised qualified personnel

All operations described in the operating instructions manual must be carried out by trained specialist personnel, authorised by the plant operator only.

Please make sure that you have read and understood these operating instructions and that you know all applicable legislations regarding occupational safety and accident prevention prior to installation and putting the component into operation.

The machine builder must carefully select the harmonised standards to be complied with as well as other technical specifications for the selection, mounting and integration of the components.

1.3 Explanation of the symbols used



Information, hint, note: This symbol is used for identifying useful additional information.



Caution: Failure to comply with this warning notice could lead to failures or malfunctions.

Warning: Failure to comply with this warning notice could lead to physical injury and/or damage to the machine.

1.4 Appropriate use

The Schmersal range of products is not intended for private consumers.

The products described in these operating instructions are developed to execute safety-related functions as part of an entire plant or machine. It is the responsibility of the manufacturer of a machine or plant to ensure the correct functionality of the entire machine or plant.

The safety switchgear must be exclusively used in accordance with the versions listed below or for the applications authorised by the manufacturer. Detailed information regarding the range of applications can be found in the chapter "Product description".

1.5 General safety instructions

The user must observe the safety instructions in this operating instructions manual, the country specific installation standards as well as all prevailing safety regulations and accident prevention rules.



Further technical information can be found in the Schmersal catalogues or in the online catalogue on the Internet:
products.schmersal.com.

The information contained in this operating instructions manual is provided without liability and is subject to technical modifications.

There are no residual risks, provided that the safety instructions as well as the instructions regarding mounting, commissioning, operation and maintenance are observed.

1.6 Warning about misuse



In case of inadequate or improper use or manipulations of the component, personal hazards or damage to machinery or plant components cannot be excluded.

1.7 Exclusion of liability

We shall accept no liability for damages and malfunctions resulting from defective mounting or failure to comply with the operating instructions manual. The manufacturer shall accept no liability for damages resulting from the use of unauthorised spare parts or accessories.

For safety reasons, invasive work on the device as well as arbitrary repairs, conversions and modifications to the device are strictly forbidden, the manufacturer shall accept no liability for damages resulting from such invasive work, arbitrary repairs, conversions and/or modifications to the device.

2 Product description

2.1 Ordering code

Product type description:
AZM400Z-(1)-(2)-(3)-(4)-(5)

(1)

ST	1 Connector plug M12, 8-pin
ST2	2 Connector plug M12, 8-pin / 5-pin

(2)

without	Standard coding
I1	Individual coding
I2	Individual coding, multiple teaching

(3)

1P2P	1 serial diagnostic output and 2 p-type safety outputs (only for ST)
-------------	--

2P2P	2 serial diagnostic output and 2 p-type safety outputs (only for ST2)
-------------	---

(4)	
without	Manual release
T	Emergency exit
BOW	With securing holes for Bowden cable assembly

(5)	
without	without electronic manual release (Only for ST)
E	with electronic manual release (Only for ST2)

Actuator	AZM400-B1
-----------------	------------------



Versions AZM400Z-...-BOW may only be used in connection with Bowden cable release ACC-AZM400-BOW-.M-.M, which is available as accessory. Use without the Bowden cable release fitted is not permissible. Observe the additional notes in the operating instructions of the Bowden cable release.

2.2 Special versions

For special versions, which are not listed in the ordering code, these specifications apply accordingly, provided that they correspond to the standard version.

2.3 Purpose

The non-contact, electronic safety switchgear is designed for application in safety circuits and is used for monitoring the position and locking of movable safety guards.



The safety switchgears are classified according to EN ISO 14119 as type 4 interlocking devices. Designs with individual coding are classified as highly coded.

The first of the two safety functions is the safe shut-down of both safety outputs when unlocking or opening the guard system and making sure that the switched-off position is maintained when the guard system is open or unlocked (locking function). The second safety function (interlocking function) is the safe interlocking of a guard system which was locked only once. The locking of the guard system may only be switched off when there is no fault and a valid signal to unlock is present.

When the guard system is closed and there is a valid two-channel control signal applied by the user or through the controller, the locking bolt of the AZM400 can be driven out. As soon as the locking bolt have reached sufficient depth in the locking hole the guard system is considered to be safely locked.

The AZM400 solenoid interlock is a bi-stable system, which means the interlock remains in the last position if power is lost.



The user must evaluate and design the safety chain in accordance with the relevant standards and the required safety level. If multiple safety sensors are involved in the same safety function, the PFH values of the individual components must be added.



The entire concept of the control system, in which the safety component is integrated, must be validated to the relevant standards.

2.4 Technical Data

Homologações - Instruções

PNV_NORM_CERTIFICATION	TÜV cULus FCC IC UKCA ANATEL
------------------------	---

Propriedades globais

NORM_STANDARD	EN ISO 13849-1 EN ISO 14119 EN IEC 60947-5-3 EN IEC 61508
CODE_GENERAL_INFO	Codificação individual, aprendizagem múltipla
CODE_CODING_LEVEL_ISO14119	Alto
DESIGN_ACTIVE_PRINCIPLE	Campo magnético RFID
TIME_FREQ_BAND_RFID	125
PWR_TRANSMIT_RFID_MAX	-6
MAT_HOUSING	Metal leve fundido sob pressão
TIME_RESPONSE_ACT_MAX	100
SAP_WEIGHT_GROSS	692

Propriedades globais - Características

YN_INTLK_MONITORING	Sim
YN_ELEC_AUX_RELEASE	Sim
YN_AUX_RELEASE	Sim
YN_SHORT_CIRCUIT_DETECT	Sim
YN_CROSS_SHORT_DETECT	Sim
YN_FIT_FOR_SAFE_FUNC	Sim
YN_INTEGR_DISPLAY_STATUS	Sim
NUM_OF_DIAGN_SIGNAL	2

NUM_OF_SAFE_CONT	2
------------------	---

Classificação

SAFE_NORM_STANDARD	EN ISO 13849-1 EN IEC 61508
--------------------	--------------------------------

Classificação - função de solenóide adicional

SAFE_PERFORM_LEVEL_INTLK	e
SAFE_CAT_INTLK	4
SAFE_PFH_VALUE_INTLK	$1,00 \times 10^{-9}$
SAFE_PFD_VALUE_INTLK	$9,00 \times 10^{-5}$
SAFE_SIL_INTLK	3
SAFE_MISSION_TIME_INTLK	20

Classificação - função de bloqueio

SAFE_PERFORM_LEVEL_GRDLK	e
SAFE_CAT_GRDLK	4
SAFE_PFH_VALUE_GRDLK	$1,80 \times 10^{-9}$
SAFE_PFD_VALUE_GRDLK	$1,60 \times 10^{-4}$
SAFE_SIL_GRDLK	3
SAFE_MISSION_TIME_GRDLK	20

Dados mecânicos

DESIGN_LOCKING_MECHANISM	biestável
DESIGN_MECH_LIFETIME_SWITCH_MIN	1 000 000
NOTE_DESIGN_MECH_LIFETIME	Dos quais, com força transversal $F_{transv} = 100 \text{ N}$: 100.000 ciclos de comutação
DIM_DIST_INTLK_TO_ACT_MIN	1
DIM_DIST_INTLK_TO_ACT_MAX	7
DIM_ANGLE_OFFSET_INTLK_ACT_MAX	2
DIM_DIST_BETWEEN_DEV_MIN	30
FORCE_HOLDING_ISO14119	10 000
FORCE_HOLDING_MAX	13 000
FORCE_LATERAL_BOLT_RETURN_MAX	300
NOTE_FORCE_LATERAL_BOLT_RETURN	Não aplicável para desbloqueio-, Cabo Bowden- e desbloqueio auxiliar
DESIGN_MOUNTING_SCREW	2x M6
NOTE_DESIGN_MOUNTING_SCREW	Classe de resistência mín. 10.9

TRQ_TIGHTEN_SCREW	8
NOTE_TRQ_TIGHTEN_SCREW	O binário de aperto máximo do parafuso da tampa (tampa triangular) é de 0,55 Nm.

Dados mecânicos - Tecnologia conectiva

REVIEW_ELEC_WIRING_GENERAL	2 conectores M12, de 8 e 5 polos, ambos com codificação A
----------------------------	---

Dados mecânicos - dimensões

DIM_LENGTH_SENSOR	46,7
DIM_WIDTH_SENSOR	77,8
DIM_HEIGHT_SENSOR	156,7

Ambiente

DESIGN_IP_CLASS_GENERAL	IP66 IP67
TEMP_AMB_GPV	-20 ... +55 °C
TEMP_STORAGE_AND_TRANSPORT_GPV	-40 ... +85 °C
APP_REL_HUMIDITY_MAX	93
NOTE_REL_HUMIDITY	não condensado sem gelo
REVIEW_RESIST_VIBRAT_EN60068_2_6	10 ... 150 Hz, amplitude 0,35 mm
REVIEW_RESTIST_TO_SHOCK	30 g / 11 ms
DESIGN_PROTECT_CLASS_ROMAN	III
DIM_HEIGHT_OPERAT_ALTITUDE_MAX	2 000

Ambiente - Parâmetros de isolamento

VOLT_RATED_INSULAT	32 VDC
VOLT_RATED_IMPULSE_WITHSTAND	0,8
DESIGN_OVERVOLT_CAT_VDE100_ROMAN	III
DESIGN_DEG_OF_POLLUT_VDE100	3

Dados elétricos

VOLT_OPERAT_GPV	24 VDC -15 % / +10 % (fonte de alimentação PELV)
VOLT_OPERAT_AUX_UHE	24 VDC -15% / +10% (UPS / fonte de alimentação ininterrupta)
CURR_NO_LOAD_CURR	100
CURR_CONSUMPT_MOTOR_SWITCH_PEAK	600 mA / 100 ms
VOLT_RATED_OPERAT_DC	24

CURR_REQUIRED_RATED_SHORT_CIRCUIT	100
ELEC_EXT_WIRE_DEV_FUSE_RATING	2A gG
TIME_TO_READINESS_MAX	1 500
TIME_SWITCH_FREQ_MAX	0,3
TIME_OPEN_CLOSE_CYCLE_MIN	3
TIME_MEAN_ZYKLUS_MIN	20
ELEC_UTILISAT_CAT_DC12_DIAGN_OUT_GPV	24 VDC / 0,05 A
ELEC_FUSE_OPERAT_CURR_MAX	2

Dados elétricos - Entradas de comando Função de bloqueio

ELEC_DEV_PORT_GRDLK_IN	E1 e E2 (comutação p), E3 (comutação n)
ELEC_SWITCH_THRESHOLDS_GRDLK_IN	-3 V ... 5 V (Low) 15 V ... 30 V (High)
ELEC_CLASS_CB24I_SINK_GRDLK_IN	C0
ELEC_CLASS_CB24I_SOURCE_GRDLK_IN	C1 C2 C3
CURR_CONSUMPT_AT_24V_GRDLK_MIN	5
CURR_CONSUMPT_AT_24V_GRDLK_MAX	10
TIME_DISCREPANCY_GRDLK_IN_MAX	10
TIME_TEST_PULSE_INTVL_GRDLK_MAX	40
TIME_TEST_PULSE_DURAT_GRDLK_MAX	5
CURR_LEAKAGE_GRDLK_MAX	1,5

Dados elétricos - Saídas digitais seguras

ELEC_DEV_PORT_SOUT	Y1 e Y2
DESIGN_SWITCH_OUT_SAFE	À prova de curto-circuito, tipo p
VOLT_DROP_SDOOUT_MAX	2
CURR_LEAKAGE_SDOOUT_MAX	0,5
VOLT_UTILISAT_CAT_DC12_SDOOUT	24
CURR_UTILISAT_CAT_DC12_SDOOUT	0,25
VOLT_UTILISAT_CAT_DC13_SDOOUT	24
CURR_UTILISAT_CAT_DC13_SDOOUT	0,25
TIME_TEST_PULSE_INTERVAL_SDOOUT_TYP	1000
TIME_TEST_PULSE_DURAT_SDOOUT_MAX	0,5
ELEC_CLASS_CB24I_SOURCE_SDOOUT	C2
ELEC_CLASS_CB24I_SINK_SDOOUT	C1 C2

Dados elétricos - saída diagnóstico

ELEC_DEV_PORT_DIAGN_OUT	OUT1 / OUT2
DESIGN_SWITCH_DIAGN_OUT	À prova de curto-circuito, tipo p
VOLT_DROP_DIAGN_OUT_MAX	2
VOLT_UTILISAT_CAT_DC12_DIAGN_OUT	24
CURR_UTILISAT_CAT_DC12_DIAGN_OUT	0,05
VOLT_UTILISAT_CAT_DC13_DIAGN_OUT	24
CURR_UTILISAT_CAT_DC13_DIAGN_OUT	0,05
NOTE_ELEC_DIAGN_OUT	As saídas de diagnóstico não são saídas relevantes para a segurança!

Indicação de estado

NOTE_LED_STATUS_INDICAT	Estado operacional : LED amarelo Falha avaria funcional: LED vermelho Tensão de alimentação UB: LED verde indica
-------------------------	--

Descrição dos pinos

ELEC_CON_1_NOTE_PIN_ASSIGN	Connector 1
ELEC_CON_1_PIN_ASSIGN_1	OUT2 Saída para diagnóstico 2
ELEC_CON_1_PIN_ASSIGN_2	E1 1
ELEC_CON_1_PIN_ASSIGN_3	n.c.
ELEC_CON_1_PIN_ASSIGN_4	Y1 Saída de segurança 1
ELEC_CON_1_PIN_ASSIGN_5	OUT1 Saída para diagnóstico 1
ELEC_CON_1_PIN_ASSIGN_6	E3 3
ELEC_CON_1_PIN_ASSIGN_7	Y2 Saída de segurança 2
ELEC_CON_1_PIN_ASSIGN_8	E2 2
ELEC_CON_2_NOTE_PIN_ASSIGN	Connector 2
ELEC_CON_2_PIN_ASSIGN_1	A1 Tensão de alimentação UB
ELEC_CON_2_PIN_ASSIGN_2	H2 GND
ELEC_CON_2_PIN_ASSIGN_3	A2 GND
ELEC_CON_2_PIN_ASSIGN_4	H1 Tensão auxiliar Uhe
ELEC_CON_2_PIN_ASSIGN_5	FE (Terra funcional)

UL notice

For use in NFPA 79 Applications only.

Use Limited Voltage/Current power supply only.

Adapters providing field wiring means are available from the manufacturer. Refer to manufacturers information.

This device shall be powered with the use of a Listed (CYJV) cable/connector assembly rated 24Vdc, 0.6A minimum.

FCC/IC - Note

This device complies with Part 15 of the FCC Rules and contains licence-exempt transmitter/receivers that are compliant with ISED (Innovation, Science and Economic Development) Canada licence-exempt RSS standard(s).

Operation is subject to the following two conditions:

- (1) This device may not cause harmful interference signals, and
- (2) This device must be able to tolerate interference signals. These also include interference signals that could cause the device to function improperly.

This device complies with the nerve stimulation limits (ISED SPR-002) when operated at a minimum distance of 100 mm. Changes or modifications not expressly approved by K.A. Schmersal GmbH & Co. KG could void the user's authority to operate the equipment.

The licence-free transmitter/receiver contained in this device satisfies the requirements of the "Radio Standards Specification" of the Innovation, Science and Economic Development Canada (ISED) authority that apply to licence-free radio equipment. Operation is permissible under the following two conditions:

- (1) The device must not create disturbances.
- (2) The device must tolerate received radio frequency interference, even if this could impair its functionality.

This device complies with the nerve stimulation limits (ISED CNR-102) when operated at a minimum distance of 100 mm.

In the event of changes or modifications that have not been expressly approved by K.A. Schmersal GmbH & Co. KG, the user's authorisation to use the device may become ineffective.



Este equipamento não tem direito à proteção contra interferência prejudicial e não pode causar interferência em sistemas devidamente autorizados.

Para maiores informações consultar: www.gov.br/anatel

3 Mounting

3.1 General mounting instructions



Please observe the remarks of the standards EN ISO 12100, EN ISO 14119 and EN ISO 14120.

Any position is possible.



The accumulation of fine-grained dirt in the bolt area must be avoided.
In such a case it is therefore not advised to have vertical mounting, where the bolt goes upwards from below.

For the correct fixing of the solenoid interlock, the device is provided with two mounting holes for M6-screws.



The M6 screws should have at least the strength class 10.9. The tightening torque of the M6 screws is 8 Nm.



The actuator must be permanently fitted to the safety guards and protected against displacement by suitable measures (tamperproof screws, gluing, drilling of the screw heads).



Use in temperatures below freezing is permitted only with dry cold. The customer must take this into account when assembling the safety switch.

Actuating directions and switch distances

The AZM400 can be operated within the following tolerance limits:

X axis	± 4 mm
Y axis	± 4 mm
Z axis	Distance between actuator and solenoid interlock 1...7 mm with max. angle offset of 2°



The actuating curves show the typical detection range of the actuator depending on the actuating direction.

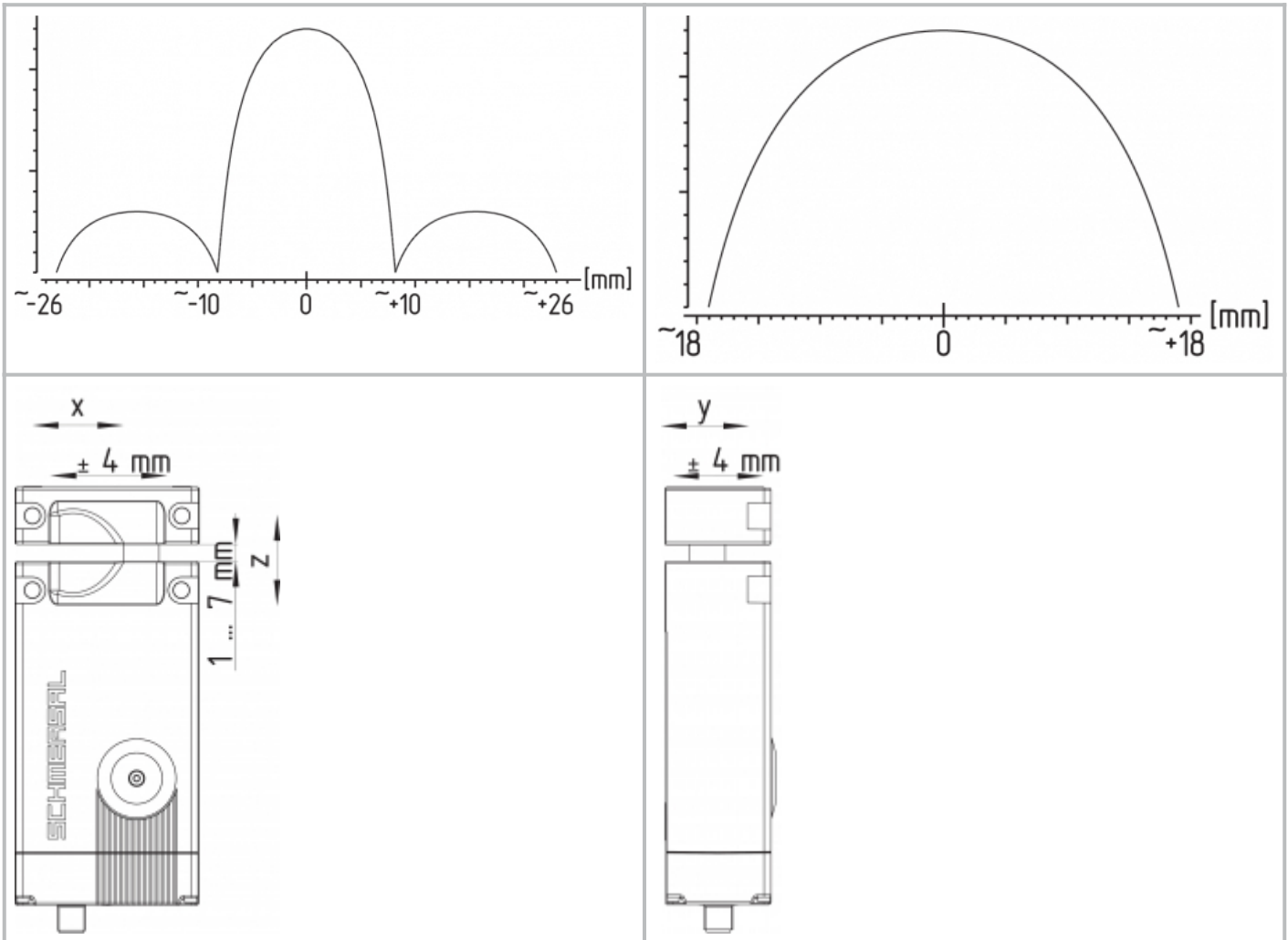

The approach direction must only be from the X and Y directions.



The maximum distance of 7 mm between the actuator and the solenoid interlock must be maintained so that the stipulated holding force and the safe clamping function is achieved according to SIL 3. The construction of the guard door is to be designed so that it is not possible to move the guard system with the actuator on the Z axis so far that the distance between the interlock and the actuator is greater than 7 mm.



The safety equipment must be designed so that there is no crushing hazard due to the movement of the bolt.

Mounting of the actuators

Refer to the mounting instructions manual for the corresponding actuator.

To avoid any interference inherent to this kind of system and any reduction of the switching distances, please observe the following guidelines:



- Metal parts and magnetic fields in the area of the solenoid interlock and the actuator can influence the switch distance or lead to malfunctions
- Keep away from metal chips

Minimum distance between two solenoid interlocks

as well as other systems with same frequency (125 kHz): 30 mm



3.2 Manual release

For the machine set-up, the solenoid interlock can be unlocked in a de-energised condition. Turning the triangle of the manual release using the triangular key to the  position releases the solenoid interlock. The normal locking function is only restored after the manual release has been returned to its original position .

Triangular key TK-M5 (101100887) available as accessory.



Structurally, after turning back the mechanical release a mechanical release that is still active can be indicated by the LEDs (all three LEDs flash). These will be reset after the control inputs are driven again.



Do not turn the manual release beyond the end stop.

After successful commissioning the attached cover is to be screwed onto the manual release and then secured with the appropriate seal. The maximum tightening torque of the cover screw is 0.55 Nm.

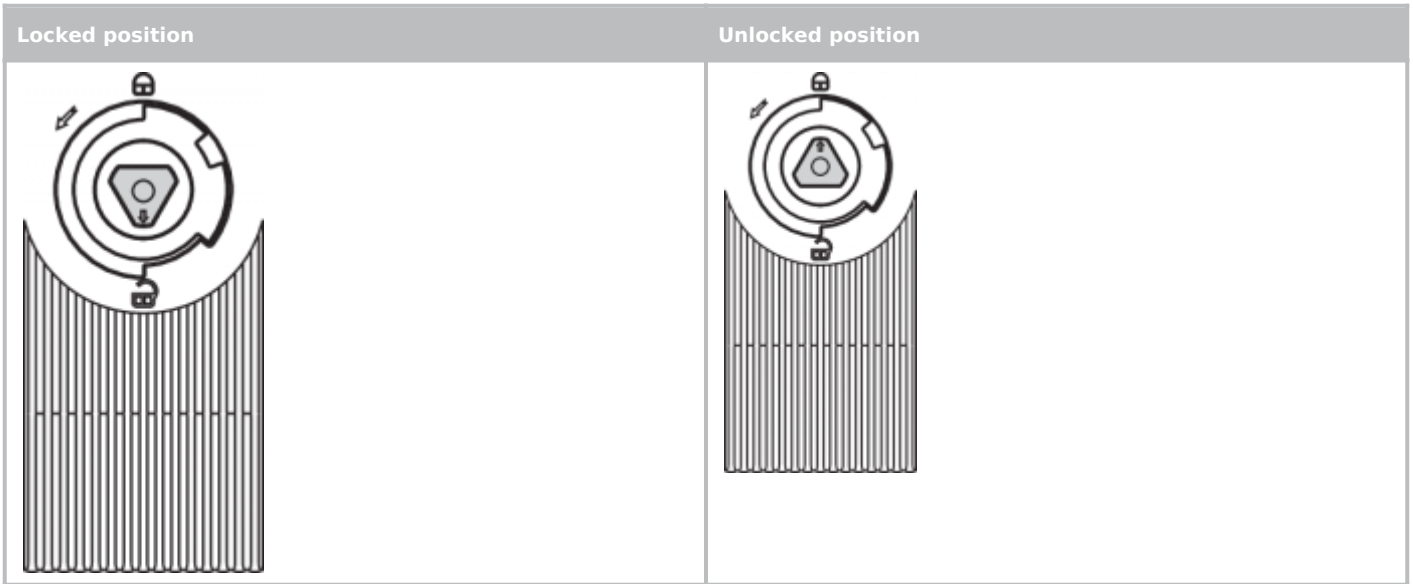

3.3 Electrical manual release - E (for -ST2)

The electrical manual release can be achieved with an additional auxiliary power supply. The auxiliary power supply unit H1 is for this purpose.

The AZM400 should only be supplied with the auxiliary power supply, this is so the locking bolt can be released independently of the control inputs.

Then no other actions are required, the safety and diagnostic units remain off.

System condition (only valid during the initialising phase):

Main supply	Auxiliary supply	System condition
0 V	0 V	Locking bolt remains in position (safety outputs switched off)
24 V	0 V	dependent on the control inputs
0 V	24 V	Locking bolt is retracted automatically (unlock)
24 V	24 V	Locking bolt remains in position (fault)



The wiring and actuation of the electrical manual release is to undergo a technical safety validation. The signal from the auxiliary power supply via UPS is then processed differently and internally so that short-circuits can be detected.

3.4 Emergency exit -T

Emergency exit for use within the hazardous area.

To activate the emergency exit, turn the red lever in the direction of the arrow to the end stop. The bolt moves due to spring force to the unlocked position so that the guard system can be opened in this position and the safety outputs switch off. In the unlocked position, the guard system is secured against unintentional locking.



Do not turn beyond the end stop.

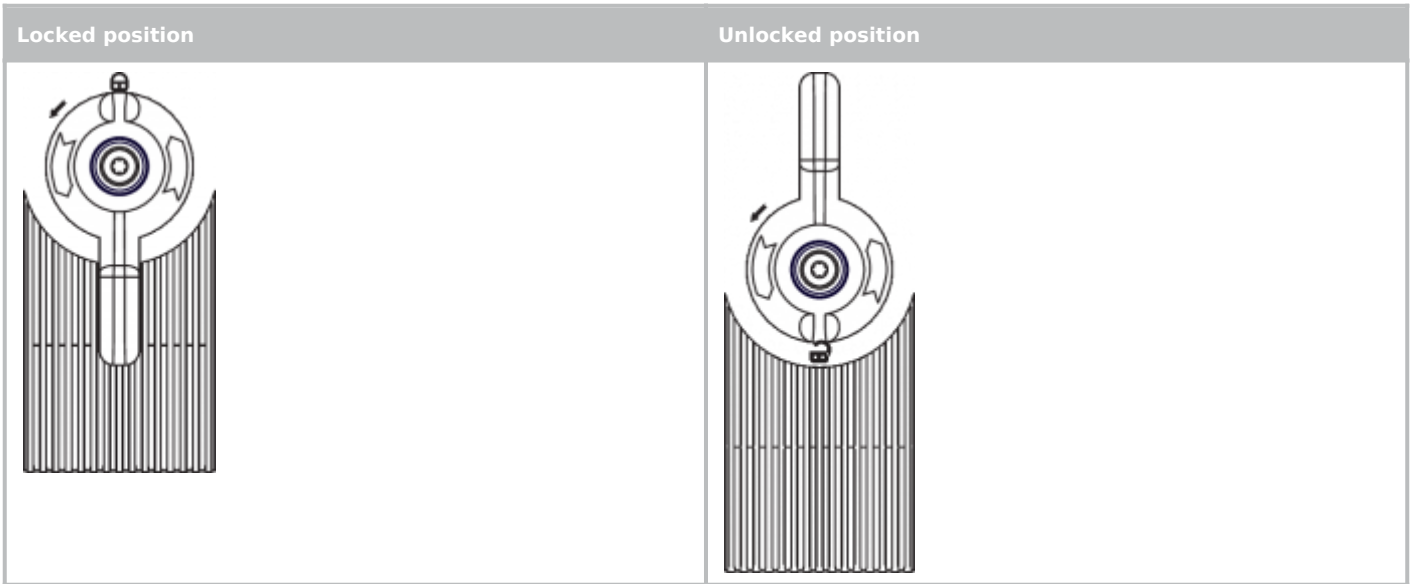

To ensure correct operation of emergency exit -T the safety door/guard must not be in a mechanically tensioned state.

3.5 Assembly with mounting set

When using 40 mm aluminium profile, the optimum mounting set MS-AZM400 can be used. This consists of two mounting plates including four bolt and four nuts.

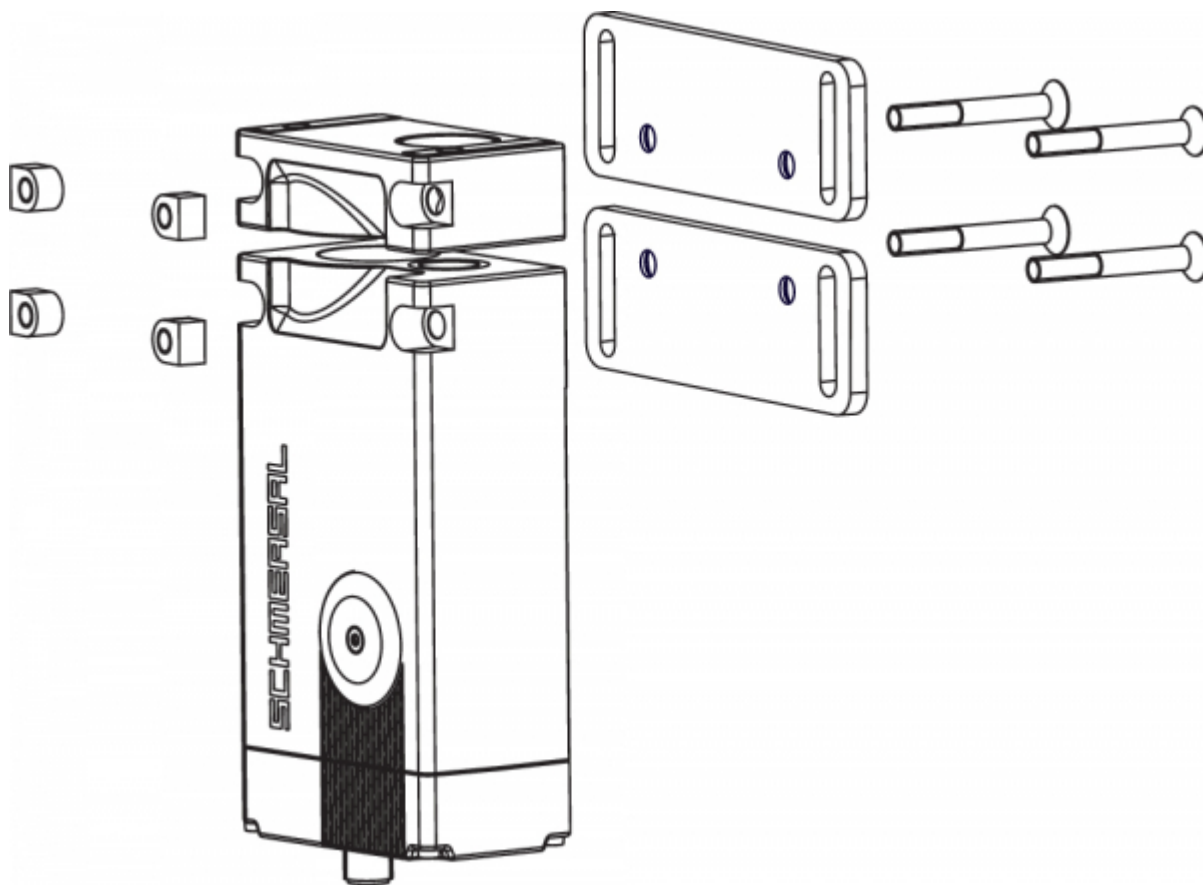

3.6 Dimensions

All measurements in mm.

AZM400Z-ST

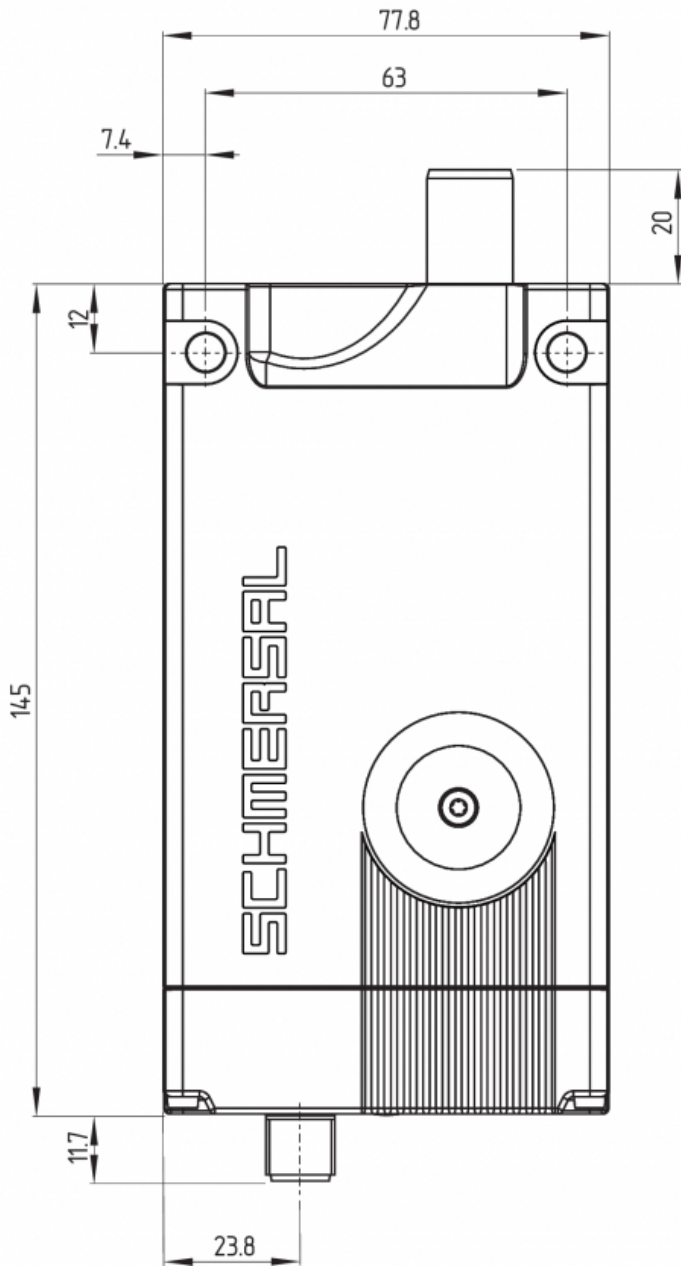

AZM400Z-ST2

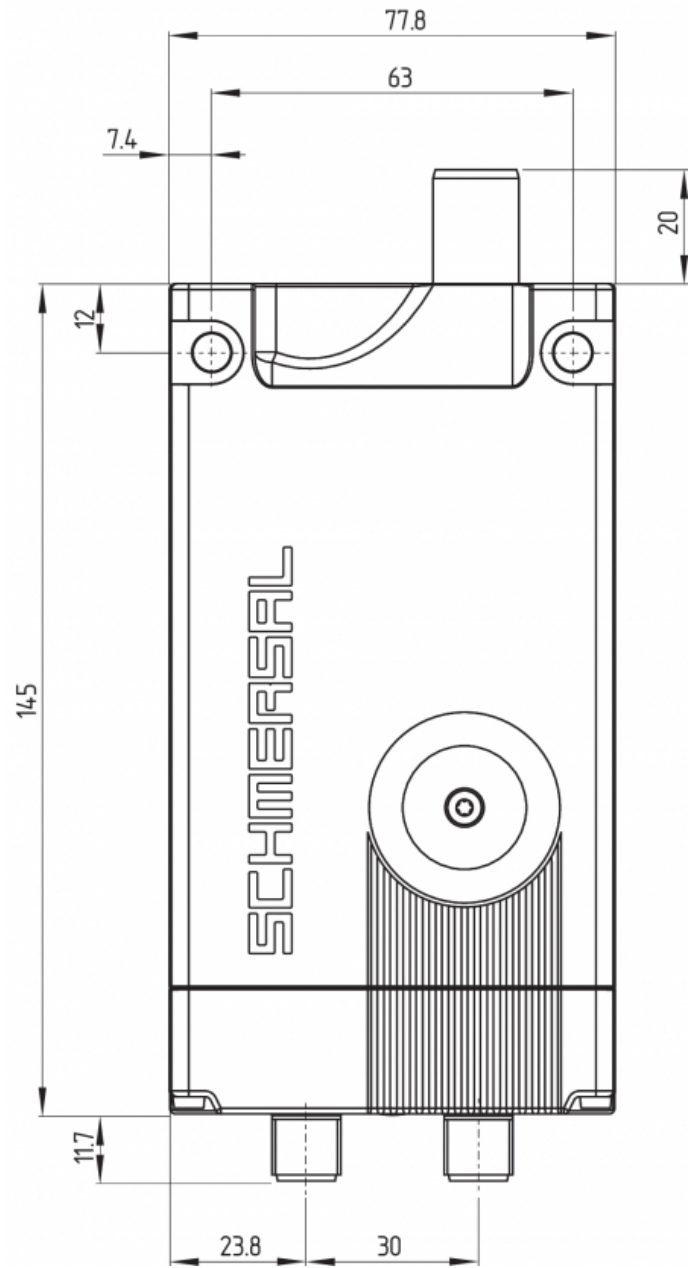



AZM400 with emergency exit



Key	
A1	Manual release with cover
A2	Emergency Exit
B	Locking bolt (extended)
C1	Connector plug M12, 8-pole
C2	Connector plug M12, 5-pole
D	RFID Sensor

3.7 Actuator and accessories

Actuator AZM400-B1 (not included in delivery)



Mounting plate, part of the mounting set MS-AZM400 (available as accessory)



Lockout tag SZ400
(available as accessory)

For detailed information and assembly instructions, see operating instructions SZ400



**Bowden cable release ACC-AZM400-BOW-.M-.M
(available as accessory)**

Observe the additional notes in the operating instructions of the Bowden cable release.



4 Electrical connection

4.1 General information for electrical connection



The electrical connection may only be carried out by authorised personnel in a de-energised condition.

The voltage inputs A1 (and H1 with the AZM400Z-ST2..), and the control inputs E1, E2 and E3 must have a permanent protection against over-voltage. The use of PELV supply units according to EN 60204-1 is recommended.

The safety outputs can be integrated into the safety circuit of the control system.

The required electrical cable fuse protection must be integrated in the installation.

4.2 Control options in the normal operating mode

Due to the control inputs E1, E2 and E3 for controlling the guard locking function it is possible to use different control options to be able to drive the AZM400 with a different safety controller. The function of the control inputs is the same for both ST and ST2 versions. Setting the operational control inputs according to the following table causes the interlock to unlock.

Input condition	Version P/P			Version P/N	
	E1	E2	E3	E1 = E2	E3
Lock	open	open	GND	open	open
Unlock	24 V	24 V	GND	24 V	GND

Use of safety outputs of the type P/P: safety controller

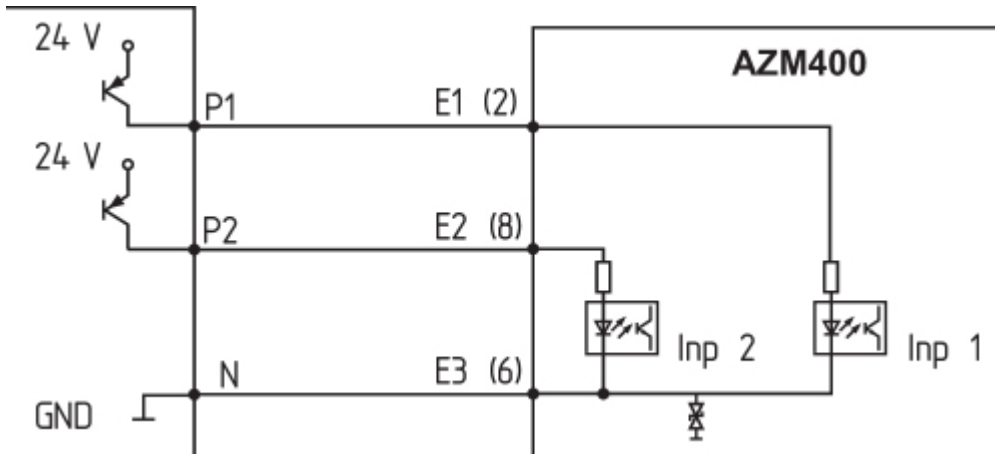

Use of safety controls of the type P/N: safety controller



The outputs used for the control must correspond to the Performance Level (PL) of the guard system. To achieve the PL e the control must have tested outputs as these are not tested by the AZM400.



Independent of the version used, the notes in the Operating Instructions of the used controller should be observed.

These could include:

- Shielded installed cable
- Minimum interval every 24 hours
- etc.

Block drive

If the locking bolt does not reach the "locked" condition with the first attempt, the AZM400 makes an autonomous attempt. If the second attempt also fails, the AZM400 signals a fault (comp. table 2).

After a malfunction, condition of the control inputs has to be changed to allow the locking bolt to be driven out again.

When the guard system closes slowly, a block drive can occur if the actuator that is opening is not in front of the bolt being driven out (see Chapter "Operating equipment and distances").

Unlocking after Power On

If after switching on, the AZM400 is already in the locked position, the device must first be unlocked and then locked again. This is to verify the causality of the drive signals and to check the sufficient depth of the locking bolt. The yellow LED flashes after power-on in the locked position.

4.3 Requirements for the connected safety-monitoring module

Dual-channel safety input, suitable for 2 p-type semi-conductor outputs (OSSD)

The solenoid interlock cyclically switch off the safety output to test them. The safety-monitoring module therefore does not need to be equipped with a cross-wire short detection. The test impulse time of ≤ 0.4 ms must be tolerated by the evaluation. The test impulse, the switch-off time of the solenoid interlock can be extended depending on the cable length and the capacity of the cable used.



Safety controller configuration

If the solenoid interlock is connected to electronic safety-monitoring modules, we recommend that you set a discrepancy time of 100 ms. The safety inputs of the safety-monitoring module must be able to blank a test impulse of < 1 ms.



4.4 Wiring configuration and connector accessories

Pin assignment of the version AZM400Z-ST-...

Function safety switchgear		Pin configuration of the connector M12, 8-pole	Colour codes of the Schmersal connector plugs to DIN 47100	Possible colour code of other commercially available connector plugs according to EN 60947-5-2
A1	U_B	1	WH	BN
E1	Control input 1	2	BN	WH
A2	GND	3	GN	BU
Y1	Safety output 1	4	YE	BK
OUT	Diagnostic output	5	GY	GY
E3	Control input 3	6	PK	PK
Y2	Safety output 2	7	BU	VT
E2	Control input 2	8	RD	OR

Pin assignment of the version AZM400Z-ST2-...

Function safety switchgear		Pin configuration of the connector M12, 8-pole	Colour codes of the Schmersal connector plugs to DIN 47100	Possible colour code of other commercially available connector plugs according to EN 60947-5-2
OUT2	Diagnostic output 2	1	WH	BN
E1	Control input 1	2	BN	WH
-	(Not connected)	3	GN	BU
Y1	Safety output 1	4	YE	BK
OUT1	Diagnostic output 1	5	GY	GY
E3	Control input 3	6	PK	PK
Y2	Safety output 2	7	BU	VT
E2	Control input 2	8	RD	OR

Function safety switchgear		Pin configuration of the connector M12, 5-pole	Colour codes of the Schmersal connector plugs to DIN 47100	Possible colour code of other commercially available connector plugs according to EN 60947-5-2
				
A1	U_B	1	BN	WH
H2	E	2	WH	BN
A2	GND	3	BU	GN
H1	U_{he}	4	BK	YE
FE	Functional earth connection 3	5	GY	GY

Accessories Pre-wired cables

Pre-wired cables with socket (female) M12, 8-pole - 8 x 0.25 mm ² , IP67 / IP69	
Cable length	Ordering code
2.5 m	103011415
5.0 m	103007358
10.0 m	103007359
15.0 m	103011414

Pre-wired cables with socket (female) M12, 5-pole - 5 x 0.34 mm ²	
Cable length	Ordering code
5.0 m	103010816
10.0 m	103010818

Further versions in other lengths and with angled cable exit are available upon request.

4.5 Wiring examples

The application examples shown are suggestions. They however do not release the user from carefully checking whether the switchgear and its set-up are suitable for the individual application. The application examples shown are suggestions.

Wiring example 1: AZM400Z-ST



Key, wiring

Connector plug M12, 8-pole

A1	U_B
A2	GND
E1	Control input 1
E2	Control input 1
E3	Control input 2
Y1	Safety output 1
Y2	Safety output 2
OUT	Diagnostic output

Wiring example 2: AZM400Z-ST2

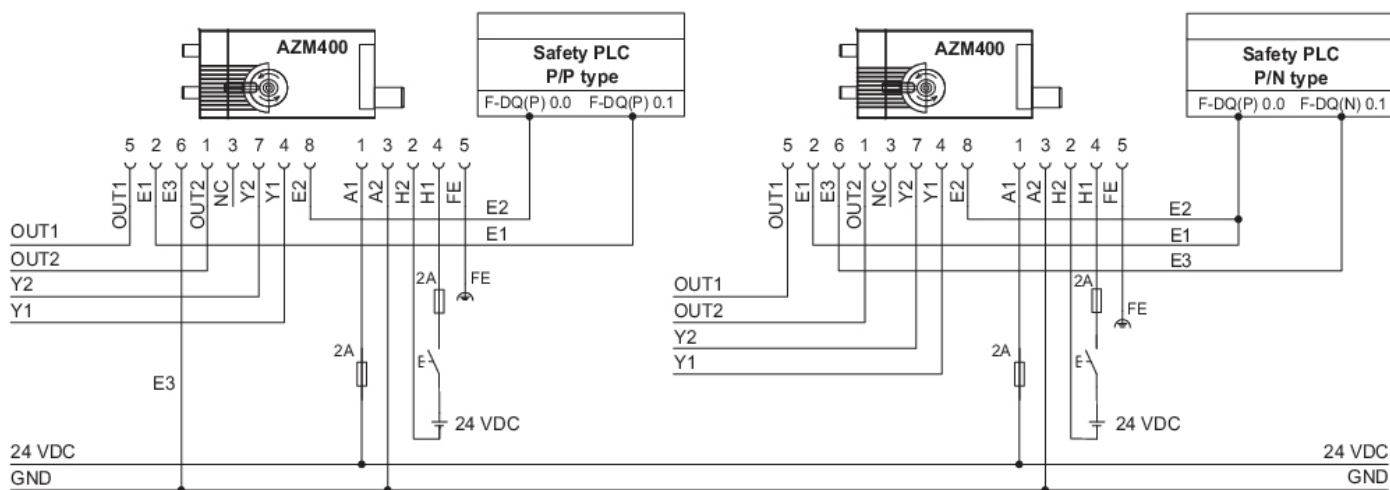

Key, wiring			
Connector plug M12, 8-pole		Connector plug M12, 5-pole	
E1	Control input 1	A1	U _B
E2	Control input 2	A2	GND
E3	Control input 3	H1	U _{he}
Y1	Safety output 1	H2	E
Y2	Safety output 2	FE	Functional earth connection
OUT1	Diagnostic output 1		
OUT2	Diagnostic output 2		

5 Actuator teaching / actuator detection

Solenoid interlocks with standard coding are ready to use upon delivery.

Individually coded solenoid interlocks and actuators will require the following "teach-in" procedure:

1. Switch the solenoid interlock's voltage supply off and back on.
2. Introduce the actuator in the detection range. The teach-in procedure is signalled at the solenoid interlock, green LED off, red LED on, yellow LED flashes (1 Hz).
3. After 10 seconds, brief yellow cyclic flashes (3 Hz) request the switch-off of the operating voltage of the solenoid interlock. (If the voltage is not switched off within 5 minutes, the solenoid interlock cancels the "teach-in" procedure and signals a false actuator by 5 red flashes.)
4. Once the operating voltage is switched back on, the actuator must be detected once more in order to activate the actuator code that has been taught in. In this way, the activated code is definitively saved!

For ordering suffix -I1, the executed allocation of safety switchgear and actuator is irreversible.

For ordering suffix -I2, the "teach-in" procedure for a new actuator can be repeated an unlimited number of times. When a new actuator is taught, the code, which was applicable until that moment, becomes invalid. Subsequent to that, an enabling inhibit will be active for ten minutes, thus providing for an increased protection against tampering. The green LED will flash until the expiration of the time of the enabling inhibit and the detection of the new actuator. In case of power failure during the lapse of time, the 10-minutes tampering protection time will restart.



Make organisational measures against possible manipulation with other actuators in case that a standard coded variant is used.

6 Active principle and diagnostic functions

6.1 Mode of operation of the safety outputs

With the solenoid interlock AZM400, the unlock signals immediately switch off the safety outputs. The unlocked guard system can be locked again as long as the actuator is within the detection range of the solenoid interlock. In that case, the safety outputs are re-enabled.

If the safety outputs are already enabled, any error that does not immediately affect the functionality of the solenoid interlock (e.g. too high an ambient temperature, interference potential at the safety outputs, cross-wire

short) will lead to a warning message, the disabling of the diagnostic output OUT of the ST version and OUT2 of the ST2 version and the delayed shutdown of the safety outputs. safety outputs are disabled if the error warning is active for 30 minutes. The signal combination, diagnostic output OUT of the ST version and OUT2 of the ST2 version disabled and safety channels still enabled, can be used to stop the production process in a controlled manner. After rectifying the fault, the fault message is acknowledged by opening and closing the associated safety door or by switching the operating voltage off and on again.

6.2 Diagnostic-LEDs

The solenoid interlock signals the operating condition, as well as errors through 3-colour LEDs.

green (Power)	Supply voltage on
yellow (Status)	Operating condition
red (Fault)	Error (see table 2: Error messages / flash codes red diagnostic LED)



6.3 Diagnostic outputs

The short-circuit proof diagnostic output OUT or OUT1 and OUT2 of the ST2 version can be used for central visualisation or control functions, e.g. in a PLC. It indicates the switching condition as shown in the table 1.

The diagnostic outputs OUT or OUT1 and OUT2 are not safety relevant outputs.

Error

Errors, which no longer guarantee the safe function of the solenoid interlock (internal errors) cause the safety outputs to be immediately disabled. Any error that does not immediately affect the safe functionality of the solenoid interlock (e.g. excess ambient temperature, safety output to external potential, short circuit) will lead to a delayed shut-down (refer to table 2). After the rectification of the error, the error message is reset by opening the corresponding safety guard.

Errors on the control inputs do not cause the shut-down of the safety outputs.

Error warning

A fault has occurred, which causes the safety outputs to be disabled after 30 minutes (LED "fault" flashes, see Table 2). The safety outputs initially remain enabled (max. 30 minutes). This enables the shutdown of the process in a controlled manner. An error warning is deleted when the cause of error is eliminated.

6.4 Diagnostic information

Table 1: Diagnostic information of the solenoid interlock AZM400

System condition	Control signals Guard locking function	LED			Safety outputs Y1, Y2	Diagnostic outputs		
		green	red	yellow		ST version OUT	ST2 version OUT1	ST2 version OUT2
Door open and unlocked (bolt retracted)	Unlock	On	Off	Off	0 V	0 V	0 V	0 V
Door closed and unlocked (bolt retracted)	Unlock	On	Off	Flashes	0 V	24 V	0 V	0 V
Door closed, lock action active (Bolt moving forwards)	Lock	On	Off	Flashes	0 V	0 V	0 V	24 V
Door closed and locked (Bolt extended)	Lock	On	Off	On	24 V	24 V	24 V	24 V
Door closed, unlocking action active (Bolt being retracted)	Unlock	On	Off	Flashes	0 V	0 V	24 V	24 V
Error states:								
Error warning ¹⁾	Without meaning	On	Flashes ²⁾	On	24 V	0 V	24 V	0 V
Error	Without meaning	On	Flashes ²⁾	Off	0 V	0 V	24 V	0 V
Mechanical auxiliary release, emergency release or Bowden cable release active	Without meaning	Flashes	Flashes	Flashes	0 V	24 V	0 V	24 V
Electronic manual release active	Without meaning	Flashes	Flashes	Flashes	0 V	-	0 V	0 V
Teaching the actuator at execution I1/I2:								
Teach-in procedure actuator started	Unlock	Off	On	Flashes slowly	0 V	0 V	0 V	0 V

Actuator teaching can be completed	Unlock	Off	On	Flashes quickly	0 V	0 V	0 V	0 V
Only I2: Actuator has been taught (Manipulation protection time is running)	Unlock	Flashes	Off	Off	0 V	24 V	0 V	24 V

1) after 30 min. disabling due to fault
2) see flash code

Table 2: Error messages / flash codes red diagnostic LED			
Flash codes (red)	Designation	Autonomous switch-off after	Error cause
1 flash pulse	Error (warning) at output Y1	30 min	Fault in output test or voltage at output Y1, although the output is disabled.
2 flash pulses	Error (warning) at output Y2	30 min	Fault in output test or voltage at output Y2, although the output is disabled.
3 flash pulses	Error (warning) cross-wire short	30 min	Cross-wire short between the output cables or fault at both outputs
4 flash pulses	Error (warning) temperature too high	30 min	The temperature measurement reveals an internal temperature that is too high
5 flash pulses	Actuator fault	0 min	Incorrect or defective actuator
6 flash pulses	Error control inputs / electronic manual release	-	Invalid input condition of the control inputs and/or of the electronic manual release
7 flash pulses	Fault with the actuator detection	0 min	Distance between the AZM400 and the actuator is too large; external magnetic fields prevent detection
8 flash pulses	Fault Block drive	0 min	Actuator not properly aligned for the solenoid interlock
9 flash pulses	Fault over/under voltage	0 min	Supply voltage outside specification
Continuous red	Internal error	0 min	Device defective

Table 2.1: Error messages / flash codes yellow LED			
Flash codes (yellow)	Designation	Autonomous switch-off after	Error cause
Fast yellow flashing (2 Hz)	Error control inputs	0 min	Frequency too high (> 0.3 Hz) at control inputs E1 and E2

7 Set-up and maintenance

7.1 Functional testing

The safety function of the safety components must be tested. The following conditions must be previously checked and met:

1. Check max. axial misalignment of actuator and solenoid interlock.
2. Check max. angle displacement.
3. Make sure that it is not possible to lift the actuator in the Z axis above the extended bolt.
4. • Check for a secure installation of the actuator and the solenoid interlock
5. Fitting and integrity of the cable connections.
6. Check the switch enclosure for damages
7. Remove particles of dust and soiling.
8. For versions with emergency exit, the following should also be considered:
It should be possible to open the guard system from within the hazardous area; it should not be possible to lock the safety guard from inside.

7.2 Maintenance

In the case of correct installation and intended use, the safety switchgear is maintenance-free. A regular visual inspection and functional test, including the following steps, is recommended:

1. • Check for a secure installation of the actuator and the solenoid interlock
2. Check max. axial misalignment of actuator and solenoid interlock.
3. Check max. angle displacement.
4. Make sure that it is not possible to lift the actuator in the Z axis above the extended bolt.
5. Fitting and integrity of the cable connections.
6. Check the switch enclosure for damages
7. Remove particles of dust and soiling.



Adequate measures must be taken to ensure protection against tampering either to prevent tampering of the safety guard, for instance by means of replacement actuators.



Damaged or defective components must be replaced.

8 Disassembly and disposal

8.1 Disassembly

The safety switchgear must be disassembled in a de-energised condition only.

8.2 Disposal



The safety switchgear must be disposed of in an appropriate manner in accordance with the national prescriptions and legislations.