



EN Operating instructions. pages 1 to 10
Translation of the original operating instructions

Content

1 About this document

1.1 Function 1

1.2 Target group: authorised qualified personnel. 1

1.3 Explanation of the symbols used 1

1.4 Appropriate use 1

1.5 General safety instructions 1

1.6 Warning about misuse 2

1.7 Exclusion of liability 2

2 Product description

2.1 Ordering code 2

2.2 Special versions. 2

2.3 Comprehensive quality insurance to 2006/42/EC 2

2.4 Destination and use 2

2.5 Technical data 2

2.6 Safety classification 3

3 Mounting

3.1 General mounting instructions 3

3.2 Dimensions 3

4 Electrical connection

4.1 General information for electrical connection. 4

5 Operating principles and latching force adjustment

5.1 Mode of operation of the safety outputs. 4

6 Diagnostic functions

6.1 Diagnostic LED's 4

6.2 Safety switch with conventional diagnostic output. 5

6.3 Safety switch with serial diagnostic function 6

7 Set-up and maintenance

7.1 Functional testing. 7

7.2 Maintenance 7

8 Disassembly and disposal

8.1 Disassembly. 7

8.2 Disposal 7

9 Appendix

9.1 Wiring examples 7

9.2 Wiring configuration and connector accessories 8

9.3 EC Declaration of conformity 9

1. About this document

1.1 Function

This operating instructions manual provides all the information you need for the mounting, set-up and commissioning to ensure the safe operation and disassembly of the safety switchgear. The operating instructions must be available in a legible condition and a complete version in the vicinity of the device.

1.2 Target group: authorised qualified personnel

All operations described in this operating instructions manual must be carried out by trained specialist personnel, authorised by the plant operator only.

Please make sure that you have read and understood these operating instructions and that you know all applicable legislations regarding occupational safety and accident prevention prior to installation and putting the component into operation.

The machine builder must carefully select the harmonised standards to be complied with as well as other technical specifications for the selection, mounting and integration of the components.

1.3 Explanation of the symbols used



Information, hint, note:

This symbol is used for identifying useful additional information.



Caution: Failure to comply with this warning notice could lead to failures or malfunctions.

Warning: Failure to comply with this warning notice could lead to physical injury and/or damage to the machine.

1.4 Appropriate use

The products described in these operating instructions are developed to execute safety-related functions as part of an entire plant or machine. It is the responsibility of the manufacturer of a machine or plant to ensure the correct functionality of the entire machinery or plant.

The safety switchgear must be exclusively used in accordance with the versions listed below or for the applications authorised by the manufacturer. Detailed information regarding the range of applications can be found in the chapter "Product description".

1.5 General safety instructions

The user must observe the safety instructions in this operating instructions manual, labelled with the caution or warning symbol above, the country-specific installation standards as well as all prevailing safety regulations and accident prevention rules.



Further technical information can be found in the Schmersal catalogues or in the online catalogue on the Internet: www.schmersal.net.

The information contained in this operating instructions manual is provided without liability and is subject to technical modifications.



The entire concept of the control system, in which the safety component is integrated, must be validated to EN ISO 13849-2.

There are no residual risks, provided that the safety instructions as well as the instructions regarding mounting, commissioning, operation and maintenance are observed.

1.6 Warning about misuse



In case of inadequate or improper use or manipulations of the safety switchgear, personal hazards or damage to machinery or plant components cannot be excluded. The relevant requirements of the standard EN 1088 must be observed.

1.7 Exclusion of liability

We shall accept no liability for damages and malfunctions resulting from defective mounting or failure to comply with this operating instructions manual. The manufacturer shall accept no liability for damages resulting from the use of unauthorised spare parts or accessories.

For safety reasons, invasive work on the device as well as arbitrary repairs, conversions and modifications to the device are strictly forbidden; the manufacturer shall accept no liability for damages resulting from such invasive work, arbitrary repairs, conversions and/or modifications to the device.

2. Product description

2.1 Ordering code

This operating instructions manual applies to the following types:

MZM 120 ① ST2-②RE-A

No.	Option	Description
①	B BM	Actuator monitored combined actuator detection and locking function
②	1P2PW2	1 p-type diagnostic output and 2 p-type safety outputs, combined diagnostic signal: safety guard is closed and can be locked
	SD2P	serial diagnostic output and 2 p-type safety outputs

MZM 120-B1.1 actuator



Only if the information described in this operating instructions manual are realised correctly, the safety function and therefore the compliance with the Machinery Directive is maintained.

2.2 Special versions

For special versions, which are not listed in the order code below 2.1, these specifications apply accordingly, provided that they correspond to the standard version.

2.3 Comprehensive quality insurance to 2006/42/EC

Schmersal is a certified company to appendix X of the Machinery Directive. As a result, Schmersal is entitled to autonomously conduct the conformity assessment procedure for the products listed in Appendix IV of the MD without involving a notified body. The EC prototype test certificates are available upon request or can be downloaded from the Internet at www.schmersal.com.

2.4 Destination and use

The MZM 120 is designed for application in safety circuits and is used for monitoring the position of movable separating safety guards. A door detection sensor monitors the closed condition of the safety guard. The latching force is activated by the detection of the actuator when the safety guard is closed.

The safety function consists of safely switching off the safety outputs when the safety guard is opened and maintaining the safe switched off condition of the safety outputs for as long as the safety guard is open. The opening of the safety guard is detected by the safety sensors. The magnetic force monitoring detects when the latching force drops below a defined latching force.

The MZM 120 distinguishes between a low holding force, which prevents the safety guard from inadvertently bursting open and a latching force F , which prevent inadvertent interventions in the machine.

Series-wiring

Series-wiring can be set up. The response and risk times are not altered by wiring in series. The number of components is only limited by the external cable protection according to the technical data and the line loss. Up to 31 components can be wired in series.

In devices with serial diagnostics function (ordering suffix -SD), the serial diagnostics connections are wired in series and connected to a SD-Gateway for evaluation purposes.

Wiring examples for series-wiring, refer to appendix



The user must evaluate and design the safety chain in accordance with the relevant standards and the required safety level. If multiple safety switchgear are involved in the same safety function, the PFH values of the individual components must be added.

2.5 Technical data

Standards:	IEC 60947-5-3, EN ISO 13849-1, IEC 61508
Material of the housings:	Plastic, glass-fibre reinforced thermoplastic, self-extinguishing
Working principle:	inductive
Recommended actuator:	MZM 120-B1.1
Switching distances to IEC 60947-5-3:	
- assured switching distance s_{ao} :	0 mm
- assured switch-off distance s_{ar} :	1 mm
Protection class:	II \square
Switch-on time ED:	100 %
Response time:	< 150 ms
Duration of risk:	< 150 ms
Time to readiness:	< 4000 ms
Series-wiring:	up to 31 devices
Length of the sensor chain:	max. 200 m
	Cable length and cable section alter the voltage drop depending on the output current

Mechanical data:

Execution of the electrical connection:	M12 connector plug, 8 poles
Mechanical life:	$\geq 1.000.000$ operations
Notice - Mechanical life:	for safety guards ≤ 5 kg; actuating speed ≤ 0.5 m/s
Resistance to shock:	30 g / 11 ms
Resistance to vibration:	10 ... 150 Hz, amplitude 0,35 mm / 5 g
Electrically adjustable latching force (RE):	30 N ... 80 N
Holding force F_{max} :	500 N
Holding force $F_{guaranteed}$:	300 N
Tightening torque for device fixing:	8 N

Ambient conditions:

Ambient temperature:	-25 °C ... +55 °C
Storage and transport temperature:	-25 °C ... +85 °C
Relative humidity:	30% ... 95%
- no condensation	
- non-icing	
Protection class:	IP67 / IP69K
- Rated impulse withstand voltage U_{imp} :	0,8 kV
- Overvoltage category:	III
- Degree of pollution:	3

Electrical data:

Supply voltage U_b (stabilised PELV units):	20,4 V DC... 26,4 V DC
Operating current:	max. 0.6 A
- Note	plus current through the safety outputs
Switching frequency:	1 Hz
Rated operating voltage U_e :	24 VDC
Rated insulation voltage U_i :	32 VDC
Rated operating current I_e :	1 A
No-load current I_o :	max. 0.6 A
Required short-circuit current:	100 A
Device fuse rating:	2 A

Electrical data - Safety inputs:

Safety inputs:	X1 and X2 (PELV unit)
Voltage range:	-3 V ... 5 V (Low) 15 V ... 30 V (High), typically 4 mA at 24 V

Electrical data - Safety outputs:

Safety outputs:	Y1 and Y2, NO function, dual-channel
Fuse rating:	short-circuit proof, p-type
Voltage drop:	1 V
Leakage current I_l :	≤ 0.5 mA
Operating current I_{e1} :	max. 0.25 A
Minimum operating current I_m :	0.5 mA
Utilisation category:	DC-13

Electrical data - Diagnostic output:

Fuse rating:	short-circuit proof, p-type
Voltage drop:	< 4 V
Operating current I_{e2} :	max. 0.05 A
Utilisation category:	DC-13
Wiring capacitance for serial diagnostics:	max. 50 nF

Electrical data - Magnet control IN:

	(PELV unit)
Voltage range:	-3 V ... 5 V (Low) 15 V ... 30 V (High); typically 4 mA bei 24 V, dynamic 20 mA

LED switching conditions display:

- Supply voltage U_B :	green LED
- Operating condition:	Yellow LED
Error / functional defect:	red LED's

Dimensions: 40 x 179 x 40 mm



Use isolated power supply only. If the cable and connector assembly is not listed for Type 12 or higher, then the device shall be used in a Type 1 environment only.

2.6 Safety classification

Standards:	EN ISO 13849-1, IEC 61508, IEC 60947-5-3
PL:	up to e
Control category:	up to 4
PFH value:	$4.3 \times 10^{-9} / h$
SIL:	suitable for SIL 3 applications
Service life:	20 years
Classification:	PDF-M

3. Mounting

3.1 General mounting instructions

For fitting the MZM 120 safety switch and the actuator, two mounting holes for M6 screws with washers (washers included in delivery) are provided.



The safety switch must be used as end stop.

For a safe operation of the system, the angle between the safety switch and the actuator compulsory must be ≤ 2°. After fitting, the unused fixing holes must be covered by means of the provided blanking plugs. To remove these plugs, if required, exert pressure on the topmost extremity (when the connector is fitted downwards) or press on the right-hand side of the plugs on the anchorage plate of the actuator. When fitting the actuator when the safety switch is used for the protection of man, refer to the "Safety instructions".



Safety sensor and actuator must be permanently fitted to the safety guards and protected against displacement by suitable measures (tamperproof screws, gluing, drilling, pinning).



At an ambient temperature of ≥ 50 °C, the MZM 120 must be fitted so that it is protected against unintentional contact with persons. Please observe the remarks of the standards EN ISO 12100, EN 953 and EN 1088.



The safety component must be operated in the operating direction of the latching force (refer to image).

Axial misalignment and operating direction of the latching force

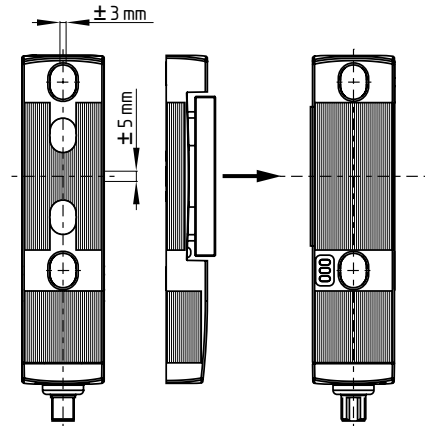

3.2 Dimensions

All measurements in mm.

Safety switch

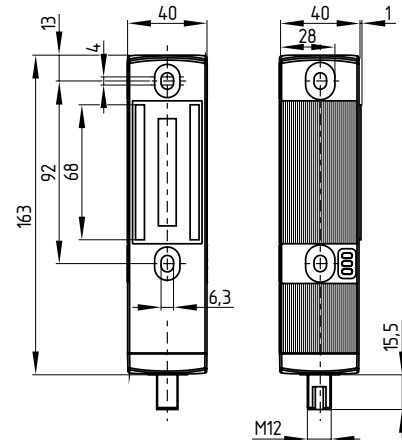

Actuator

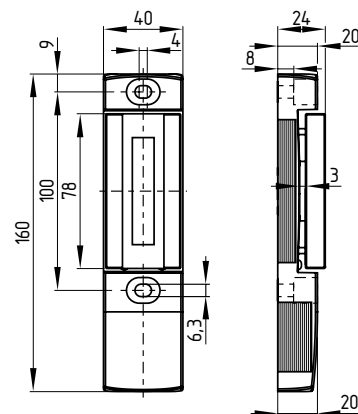

4. Electrical connection

4.1 General information for electrical connection



The electrical connection may only be carried out by authorised personnel in a de-energised condition.

The voltage inputs A1, X1, X2 and IN must have a protection against permanent overvoltage. Therefore, the use of PELV supply units according to IEC 60204-1 is recommended.

The safety outputs can be integrated in the safety circuit of the control system. For applications of PL e / control category 4 to EN ISO 13849-1, the safety outputs of the safety switchgear or the chain of components must be connected to a safety-monitoring module of the same category. (see wiring examples)

Requirements for the connected safety-monitoring module:

- Dual-channel safety input, suitable for 2 p-type semi-conductor outputs
- **Test function**

The safety-monitoring module must tolerate internal functional tests of the sensors with cyclic switch-off of the sensor outputs for max. 2 ms (typically < 1 ms). The switch-off stage of the test cycle is temporarily reduced by an active ohmic discharge of the cable. The safety-monitoring module does not need to have a cross-wire short monitoring function, if necessary, the cross-wire short monitoring function must be disabled.



Information for the selection of suitable safety-monitoring modules can be found in the Schmersal catalogues or in the online catalogue on the Internet: www.schmersal.net.

If the safety component is wired to relays or to non-safety relevant control components, a new risk analysis must be carried out.



When wiring SD devices, please observe the voltage drop on the cables and the current carrying capacity of the individual components.

5. Operating principles and latching force adjustment

5.1 Mode of operation of the safety outputs

MZM 120 B

Due to the permanent monitoring of the closed magnetic circuit, the safety outputs Y1/Y2 are only enabled during the latching, when the magnetic circuit is properly closed and the latching force F can also be obtained when activated. If the metal surfaces are soiled or damaged, the enabling signal is not transmitted.

The unlocking of the MZM 120 safety switch with interlocking function does not lead to a switch-off.

MZM 120 BM

The safety outputs are enabled when the actuator is present on the safety switch and the magnet control is activated. The unlocking of the safety switch causes the safety outputs to be disabled within the duration of risk. As long as the actuator is inserted into the safety switch, the unlocked safety switch with interlocking function can be relocked. In this case, the safety outputs are re-enabled.

The latching force F is permanently measured and checked. In this way, soiling of the solenoid interlock can be detected. If the latching force drops below 300 N, the release signal for the safety outputs Y1 and Y2 is not given.

Description of the MZM 120 latching force adjustment

The latching force of the MZM 120 can be set in 8 steps each within a range of approx. 30 N to approx. 80 N. To this end, the adjustment target MZM 100 TARGET is used directly on the fitted MZM 120.

Adjustment of the latching force

- 1.) Open the safety guard and isolate the MZM 120 from the voltage supply. Either switch off the voltage supply or pull out the connector.
- 2.) Put the adjustment target with the active side on the identification plate of the MZM 120.
- 3.) Switch the voltage supply of the MZM 120 back on and wait at least 10 seconds before removing the adjustment target. The component searches for the adjustment target. When the adjustment mode is active, the safety outputs remain disabled.
- 4.) Remove the adjustment target again from the component. The yellow LED of the MZM 120 will repeatedly flash briefly to show the currently set latching force level (e.g. 4 flashes = 4th latching force level approx. 51 N).
- 5.) Put the adjustment target approx. 1 second back on the solenoid interlock with the safety guard open to gradually increase the latching force by each time one step. The number of flashes will increase accordingly.

The modified latching force can be checked directly on the safety guard. If necessary, the latching force can be increased by another step. When latching force level 8 is reached, level 1 will be activated when the adjustment target is placed back on the component.

- 6.) Switch off the voltage supply of the MZM 120 once more to permanently save the chosen latching force.

When the component is switched off, the adjustment mode is quit. After the voltage supply is switched back on, the MZM 120 is ready for operation.

Latching force indication

If the voltage supply of the MZM 120 is switched on when the safety guard is open, the yellow LED will show the set latching force for 10 seconds by means of repeated brief flashes (e.g. 4 flashes = 4th latching force level approx. 50 N).

Description of the latching force adjustment for the MZM 120-...-SD with serial diagnostic function

The latching force can be set through the latching force bits 1-3 of the request bytes in 8 steps within a range of approx. 30 - 80 N.

Latching force bit	3	2	1	Latching force RE
0	0	0	0	30 N
0	0	1	0	37 N
0	1	0	0	44 N
0	1	1	0	51 N
1	0	0	0	58 N
1	0	1	0	65 N
1	1	0	0	72 N
1	1	1	0	80 N

6. Diagnostic functions

6.1 Diagnostic LED's

The safety switch signals the operational state as well as errors through three coloured LED's installed at the front side of the device.

- green** Supply voltage on
- red** Fault (s. Table: flash codes of the red diagnostic LED)
- yellow** Operating condition

6.2 Safety switch with conventional diagnostic output

The short-circuit proof diagnostic output OUT can be used for central visualisation or control functions, e.g. in a PLC. This is not a safety-relevant output!

Error

Errors, which no longer guarantee the function of the safety switch with interlocking function (internal errors) cause the safety outputs to be disabled within the risk time. Any error that does not immediately affect the safe functionality of the safety switch with interlocking function (e.g. the ambient temperature too high, interference potential at a safety output, cross-wire short) will lead to a delayed shut-down (refer to table 2).

Behaviour of the diagnostic outputs of the W variant

Input signal magnet control

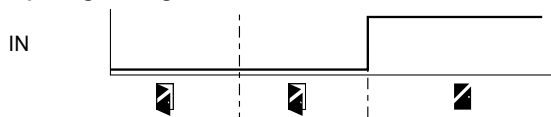

Normal sequence, door was locked



Door could not be locked or fault



Legend

- Safety guard open
- Safety guard closed
- unlock guard
- Safety guard locked
- Locking time
- Guard not locked or fault

After fault rectification, the sensor can be reset by opening the relevant guard door.



If more than one fault is detected at the safety outputs, the component will be electronically locked and a normal fault reset will no longer be possible.

To reset this type of interlocking, the component must be isolated from the power supply after elimination of the error causes.

Error warning

A fault has occurred, which causes the safety outputs to be disabled after 30 minutes. The safety outputs initially remain enabled. This enables the shutdown of the process in a controlled manner. An error warning is deleted when the error cause is eliminated.

Evaluation of the diagnostic outputs

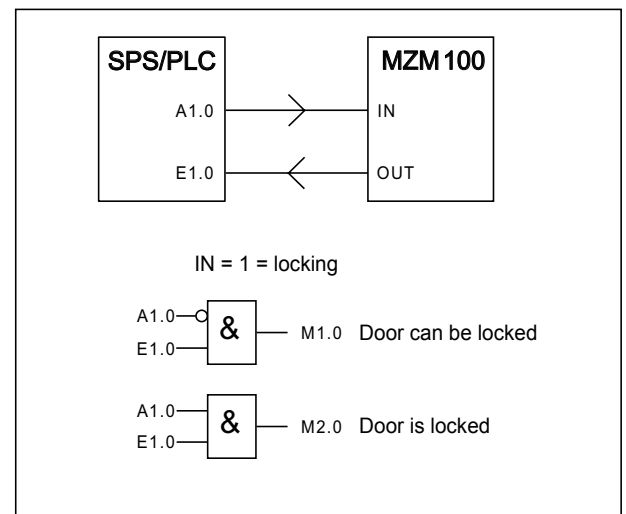

Table 1: the diagnostic function of the MZM 120 safety switch with additional interlocking function

The diagnostic output OUT signals faults before the safety outputs are disabled, thus enabling a controlled shutdown.

System condition	Solenoid control IN	LED green	LED red	LED yellow	Safety outputs Y1, Y2	Diagnostic output OUT
Safety guard open	0 V	On	Off	Off	0 V	0 V
Safety guard closed, actuator in, safety guard can be locked	0 V	On	Off	Flashes	24 V	24 V
Safety guard closed and locked	24 V	On	Off	On	24 V	24 V
Solenoid interlock cannot be locked, safety guard not correctly closed or solenoid soiled	24 V	On	Off	Off	0 V	0 V
Error warning ¹⁾ , actuator in	0 V / 24 V	On	flashes ²⁾	flashes/on	24 V	0 V
Error	0 V / 24 V	On	flashes ²⁾	Off	0 V	0 V

¹⁾ after 30 min -> fault

²⁾ refer to flash code

Table 2: flash codes red LED

Flash codes (red)	Designation	Autonomous switch-off after	Error cause
1 flash pulse	Error (warning) at output Y1	30 min	Fault in output test or voltage at output Y1, although the output is disabled.
2 flash pulses	Error (warning) at output Y2	30 min	Fault in output test or voltage at output Y2, although the output is disabled.
3 flash pulses	Error (warning) cross-wire short	30 min	Cross-wire short between the output cables or fault at both outputs. After 30 minutes, voltage switch-off/on required
5 flash pulses	Actuator fault	0 min	incorrect or defective actuator
6 flash pulses	Latching force fault	0 min	Latching force has dropped below 300 N (e.g. actuator misalignment)
10 flash pulses	Magnet temperature too high	0 min	The magnet is too hot: $T > 70\text{ °C}$.
continuous red signal	internal error	0 min	

6.3 Safety switch with serial diagnostic function

Safety switches with serial diagnostic cable have a serial input and output cable instead of the conventional diagnostic output.

Max. 31 safety switchgear with serial diagnostics can be wired in series. For the evaluation of the serial diagnostics line either the PROFIBUS-Gateway SD-I-DP-V0-2 or the Universal-Gateway SD-I-U-... are used. This SD-Gateway is integrated as slave in an existing field bus system. In this way, the diagnostic signals can be evaluated by means of a PLC. The necessary integration for the integration of the SD-Gateway is available for download at www.schmersal.net.

The response data and the diagnostic data are automatically and permanently written in an input byte of the PLC for each safety switch in the series-wired chain. The request data for each safety switch are transmitted to the component through an output byte of the PLC.

In case of a communication error between the field bus gateway and the safety switch, the switching condition of the interlocking device is maintained.

Error

A fault has occurred, which causes the safety outputs to be disabled. The fault is reset, when the cause is eliminated and bit 7 of the request byte changes from 1 to 0 or the safety guard is opened. Faults at the safety outputs are only deleted upon the next release, as the fault rectification cannot be detected sooner.



If more than one fault is detected at the safety outputs, the component will be electronically locked and a normal fault reset will no longer be possible.

To reset this type of interlocking, the component must be isolated from the power supply after elimination of the error causes.

Error warning

A fault has occurred, which causes the safety outputs to be disabled after 30 minutes. The safety outputs initially remain enabled.

Diagnostic error (warning)

If an error (warning) is signalled in the response byte, detailed fault information can be read out.



Detailed information about the use of the serial diagnostics can be found in the operating instructions of the PROFIBUS-Gateway SD-I-DP-V0-2 and the Universal-Gateway SD-I-U-....

Accessories for the series-wiring

To provide for a comfortable wiring and series-wiring of SD components, the connectors and the SD-2V-F-SK SD junction boxes (variant for the field in closed enclosure) and SD-2V-S-SK (variant for DIN rail mounting in the control cabinet) are available as accessory.

Table 3: I/O data and diagnostic data

Bit n°	Request byte	Response byte	Diagnostic error warning	Diagnostic error
Bit 0:	Magnet in, error reset	Safety output activated	Error output Y1	Error output Y1
Bit 1:	Latching force bit	Actuator detected	Error output Y2	Error output Y2
Bit 2:	Latching force bit	Solenoid interlock locked	Cross-wire short	Cross-wire short
Bit 3:	Latching force bit	---	Magnet temperature too high	Magnet temperature too high
Bit 4:	---	Input condition X1 and X2	Locking blocked or $F < 300\text{ N}$	incorrect or defective actuator
Bit 5:	---	---	Internal device error	Internal device error
Bit 6:	---	Error warning	Communication error between the field bus Gateway and the solenoid interlock	---
Bit 7:	Error reset	Error (enabling path switched off)	Operating voltage too low	Operating voltage too low

The described condition is reached, when Bit = 1

Table 4: Function of the visual diagnostic LED`s, the serial status signals and the safety outputs by means of an example

System condition	LED			Safety outputs Y1, Y2	Response byte bit n°:							
	green	red	yellow		7	6	5	4	3	2	1	0
Safety guard open	On	Off	Off	0 V	0	0	0	X	0	0	0	0
Safety guard closed, actuator in, safety guard can be locked	On	Off	Flashes	24 V	0	0	0	1	0	0	1	0
Safety guard closed and locked	On	Off	On	24 V	0	0	0	1	0	1	1	1
Solenoid interlock cannot be locked, safety guard not correctly closed or solenoid soiled	On	Off	Flashes	0 V	0	0	0	1	0	0	0	0
Error warning ¹⁾ , actuator in	On	flashes ²⁾	On	24 V	0	1	0	1	0	X	1	1
Error	On	flashes ²⁾	Off	0 V	1	0	0	X	0	X	X	0

¹⁾ after 30 min -> fault

²⁾ refer to flash code

7. Set-up and maintenance

7.1 Functional testing

The safety function of the safety components must be tested. The following conditions must be previously checked and met:

1. Check max. axial misalignment of actuator and safety switch
2. Check max. angular misalignment (see "Mounting" part)
3. Check the integrity of the cable entry and connections
4. Check the switch enclosure for damage
5. Remove particles of dust and soiling

7.2 Maintenance

In the case of correct installation and adequate use, the safety component features maintenance-free functionality. We recommend a regular visual inspection and functional test, including the following steps:

- Check the fixing of the safety switch and the actuator
- Check max. axial misalignment of actuator and safety switch
- Check max. angular misalignment (see "Mounting" part)
- Check the integrity of the cable entry and connections
- Check the switch enclosure for damages
- Remove soiling

Damaged or defective components must be replaced.

8. Disassembly and disposal

8.1 Disassembly

The safety switchgear must be disassembled in a de-energised condition only.

8.2 Disposal

The safety switchgear must be disposed of in an appropriate manner in accordance with the national prescriptions and legislations.

9. Appendix

9.1 Wiring examples

The application examples shown are suggestions. They however do not release the user from carefully checking whether the switchgear and its set-up are suitable for the individual application

Wiring example 1: Series-wiring of the MZM 120 safety switch with diagnostic output

The voltage is supplied at both safety inputs of the terminal safety component of the chain (considered from the safety-monitoring module). The safety outputs of the first safety component are wired to the safety-monitoring module.

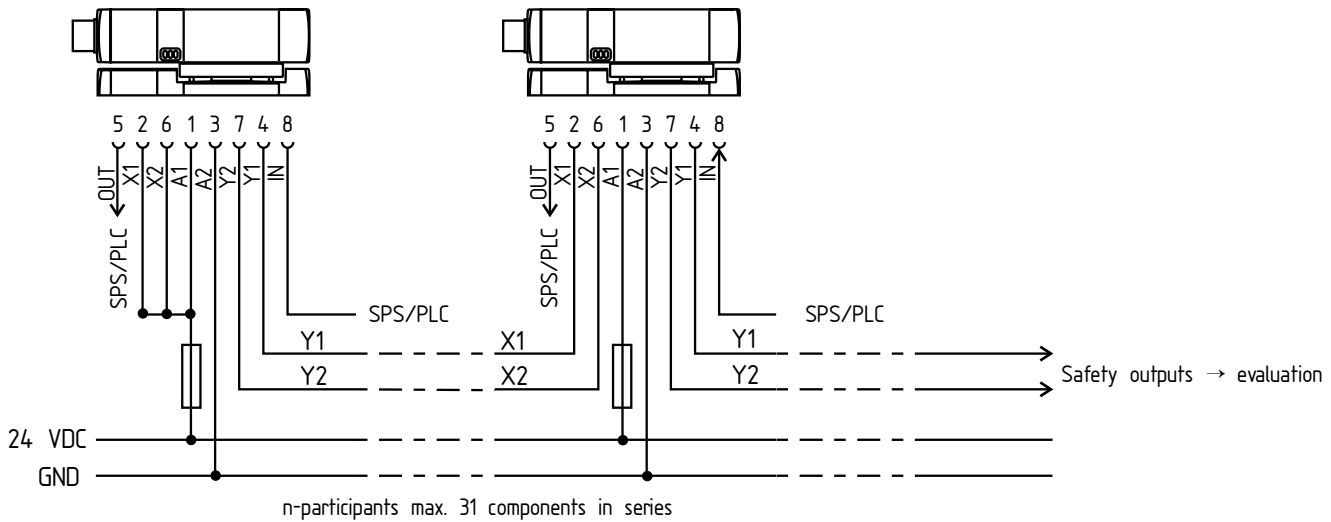

Wiring example 2: Series-wiring of the MZM 120 safety switch with serial diagnostic function

The safety outputs of the first safety component are wired to the safety-monitoring module. The serial Diagnostic Gateway is connected to the serial diagnostic input of the first safety component.

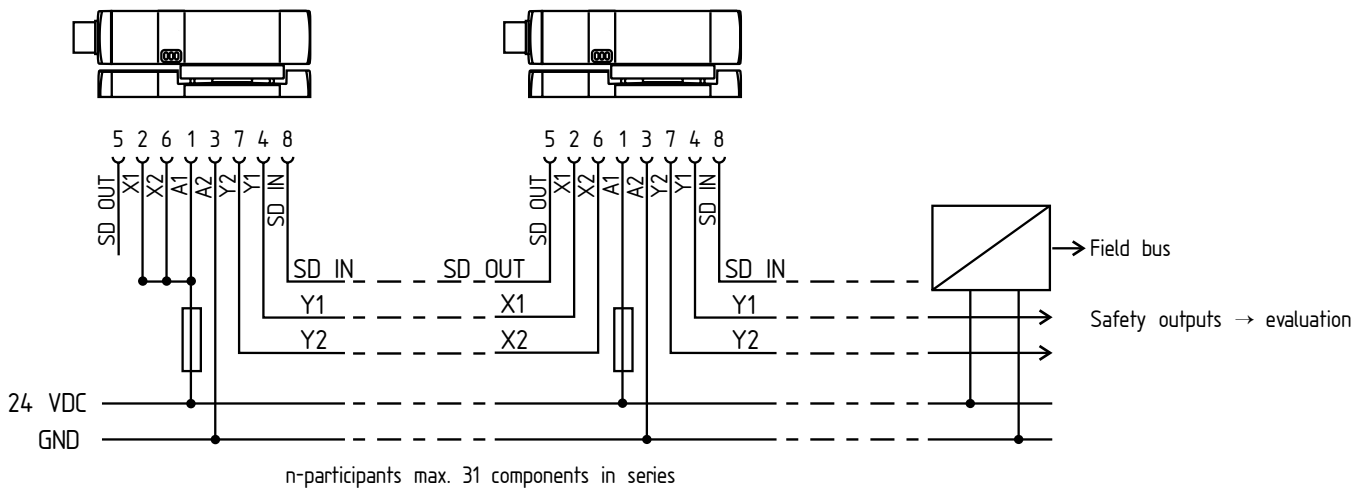

9.2 Wiring configuration and connector accessories

Function safety switchgear		Pin configuration of the connector	Colour code or conductor numbering of the below-mentioned Schmersal connectors		Possible colour code of other commercially available connectors		
with conventional diagnostic output	with serial diagnostic function				to EN 60947-5-2: 2007	DIN 47100	
A1	U _e		1	BN	1	BN	WH
X1	Safety input 1		2	WH	2	WH	BN
A2	GND		3	BU	3	BU	gn
Y1	Safety output 1		4	BK	4	BK	YE
OUT	Diagnostic output	SD output	5	GY	5	GY	GY
X2	Safety input 2		6	VT	6	PK	PK
Y2	Safety output 2		7	RD	7	VT	BU
IN	Solenoid control	SD input	8	PK	8	OR	RD

Connector plug ST2 M12, 8-pole	Connecting cables with female connector IP67, M12, 8-pole - 8 x 0.23 mm ²		Connecting cables with female connector IP69K, M12, 8-pole - 8 x 0.21 mm ²	
	Cable length	Part number	Cable length	Part number
	2.5 m	101209963	5.0 m	101210560
	5.0 m	101209964	5.0 m	101210561 (angled)
	10.0 m	101209960		

9.3 EC Declaration of conformity

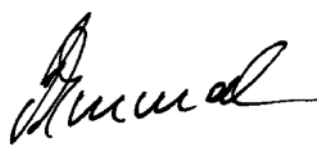
	
<h2>EC Declaration of conformity</h2>	
Translation of the original declaration of conformity	K.A. Schmersal GmbH Industrielle Sicherheitssysteme Mödinghofe 30, 42279 Wuppertal Germany Internet: www.schmersal.com
We hereby certify that the hereafter described safety components both in its basic design and construction conform to the applicable European Directives.	
Name of the safety component:	MZM 120
Type:	Refer to ordering code
Description of the safety component:	Safety switch with interlocking function
Harmonised EC-Directives:	2006/42/EC - EC-Machinery Directive 2004/108/EC - EMC-Directive
Person authorized for the compilation of the technical documentation:	Ulrich Loss Mödinghofe 30 42279 Wuppertal
Notified body, which approved the full quality assurance system, referred to in Appendix X, 2006/42/EC:	TÜV Rheinland Industrie Service GmbH Alboinstr. 56 12103 Berlin ID n°: 0035
Place and date of issue:	Wuppertal, November 29, 2011
MZM 120-A-EN	
	Authorised signature Philip Schmersal Managing Director



The currently valid declaration of conformity can be downloaded from the internet at www.schmersal.net.



K. A. Schmersal GmbH
Industrielle Sicherheitssysteme
Möddinghofe 30, D - 42279 Wuppertal
Postfach 24 02 63, D - 42232 Wuppertal

Phone: +49 - (0)2 02 - 64 74 - 0
Telefax +49 - (0)2 02 - 64 74 - 1 00
E-Mail: info@schmersal.com
Internet: <http://www.schmersal.com>