



EN Operating instructions.pages 1 to 4
Original

Content

1 About this document

1.1 Function 1

1.2 Target group: authorised qualified personnel. 1

1.3 Explanation of the symbols used 1

1.4 Appropriate use 1

1.5 General safety instructions 1

1.6 Warning about misuse 2

1.7 Exclusion of liability 2

2 Product description

2.1 Ordering code 2

2.2 Special versions. 2

2.3 Purpose 2

2.4 Technical data 2

2.5 Safety classification 2

3 Mounting

3.1 General mounting instructions 2

3.2 Dimensions 3

4 Rear side Electrical connection

4.1 General information for electrical connection. 3

4.2 Contact variants. 3

5 Set-up and maintenance

5.1 Functional testing. 3

5.2 Maintenance 3

6 Disassembly and disposal

6.1 Disassembly. 3

6.2 Disposal. 3

7 EU Declaration of conformity

1. About this document

1.1 Function

This operating instructions manual provides all the information you need for the mounting, set-up and commissioning to ensure the safe operation and disassembly of the safety switchgear. The operating instructions must be available in a legible condition and a complete version in the vicinity of the device.

1.2 Target group: authorised qualified personnel

All operations described in this operating instructions manual must be carried out by trained specialist personnel, authorised by the plant operator only.

Please make sure that you have read and understood these operating instructions and that you know all applicable legislations regarding occupational safety and accident prevention prior to installation and putting the component into operation.

The machine builder must carefully select the harmonised standards to be complied with as well as other technical specifications for the selection, mounting and integration of the components.

1.3 Explanation of the symbols used



Information, hint, note:

This symbol is used for identifying useful additional information.



Caution: Failure to comply with this warning notice could lead to failures or malfunctions.

Warning: Failure to comply with this warning notice could lead to physical injury and/or damage to the machine.

1.4 Appropriate use

The products described in these operating instructions are developed to execute safety-related functions as part of an entire plant or machine. It is the responsibility of the manufacturer of a machine or plant to ensure the correct functionality of the entire machine or plant.

The safety switchgear must be exclusively used in accordance with the versions listed below or for the applications authorised by the manufacturer. Detailed information regarding the range of applications can be found in the chapter "Product description".

1.5 General safety instructions

The user must observe the safety instructions in this operating instructions manual, the country specific installation standards as well as all prevailing safety regulations and accident prevention rules.



Further technical information can be found in the Schmersal catalogues or in the online catalogue on the Internet: www.schmersal.net.

The information contained in this operating instructions manual is provided without liability and is subject to technical modifications.



If multiple safety components are wired in series, the Performance Level to EN ISO 13849-1 will be reduced due to the restricted error detection under certain circumstances. The entire concept of the control system, in which the safety component is integrated, must be validated to EN ISO 13849-2.

There are no residual risks, provided that the safety instructions as well as the instructions regarding mounting, commissioning, operation and maintenance are observed.

1.6 Warning about misuse



In case of improper use or manipulation of the safety switchgear, personal hazards or damages to machinery or plant components cannot be excluded. The relevant requirements of the standard ISO 14119 must be observed.

1.7 Exclusion of liability

We shall accept no liability for damages and malfunctions resulting from defective mounting or failure to comply with this operating instructions manual. The manufacturer shall accept no liability for damages resulting from the use of unauthorised spare parts or accessories.

For safety reasons, invasive work on the device as well as arbitrary repairs, conversions and modifications to the device are strictly forbidden; the manufacturer shall accept no liability for damages resulting from such invasive work, arbitrary repairs, conversions and/or modifications to the device.

2. Product description

2.1 Ordering code

This operating instructions manual applies to the following types:

TZG ①②/③

No.	Option	Description
①	P	Slow action Snap action only 1 NC / 1 NO contact
②	01	Head positioned to the front
	02	Head positioned to the left
	03	Head positioned to the right
	04	Head positioned to the rear
③	103	1 NC contact / 1 NO contact
	110	2 NC contacts
	1103	2 NC contact / 1 NO contact
	3330	3 NC

Not all component variants, which are possible according to this order code, are available.



Only if the information described in this operating instructions manual are realised correctly, the safety function and therefore the compliance with the Machinery Directive is maintained.

2.2 Special versions

For special versions, which are not listed in the order code below 2.1, these specifications apply accordingly, provided that they correspond to the standard version.

2.3 Purpose

The safety switch has been designed to prevent, in conjunction with the control part of a machine, movable safety guards from being opened before hazardous conditions have been eliminated. They are also suitable for fitting on profile sections and existing equipment.



Safety switches can only be used for applications, in which the hazardous situation is terminated without delay (e.g. run-on movements) when the safety guard is opened.

When the safety guard is opened, the NC contacts are positively opened and the NO contacts are closed. The user must evaluate and design the safety chain in accordance with the relevant standards and on the required safety level.

2.4 Technical data

Standards:	IEC 60947-5-1; EN ISO 13849-1; ISO 14119; BG-GS-ET-15
Enclosure:	glass-fibre reinforced thermoplastic, self-extinguishing
Actuator:	steel
Contact material:	Silver
Protection class:	IP67
Contact type:	change-over with double break Zb, or 2 NC contacts, or 3 NC contacts, galvanically separated contact bridges
Switching system:	⊖ IEC 60947-5-1; slow action, NC contact with positive break
Connection:	screw terminals
Cable type:	solid wire
Cable section:	0,5 ... 2,5 mm ²
Cable type:	stranded wire
Cable section:	0,5 ... 1,5 mm ² , with conductor ferrules,
Cable entry:	M20 × 1,5
Actuating speed:	0.2 m/s
Actuating frequency:	max. 1200 operations/h
Mechanical life:	> 1 million operations
Ambient temperature:	-25 °C ... +70 °C
Utilisation category:	AC-15, DC-13
I _e /U _e :	8 A / 230 VAC; 5 A / 24 VDC only TZGP: 6 A / 230 VAC; 4 A / 24 VDC
U _i :	400 V only TZGP 250V
U _{imp} :	2.5 kV
I _{the} :	10 A
U _s :	24 VAC/DC 110/230 VAC
Max. fuse rating:	10 A gG D-fuse

2.5 Safety classification

Standards:	EN ISO 13849-1
B _{10d} (NC contact):	2.000.000
B _{10d} (NO contact) at 10% ohmic contact load:	1.000.000
Service life:	20 years

$$MTTF_D = \frac{B_{10D}}{0,1 \times n_{op}} \quad n_{op} = \frac{d_{op} \times h_{op} \times 3600 \text{ s/h}}{t_{cycle}}$$

3. Mounting

3.1 General mounting instructions

3/2 mounting holes are provided for fixing the switch. The safety switch must not be used as end stop. Any mounting position. The mounting position however must be chosen so that the components are protected against soiling and damage. In case of painting activities, the components must be covered. The supplied fixing material must be used. If another actuating direction is desired, the four screws of the actuating head must be loosened. Turn the actuating head in the desired direction and retighten the screws (tightening torque 0.5 Nm). The default screws installed in the actuating head can be replaced with the supplied tamperproof screws.

Mounting of the actuators: See mounting instructions actuators.



Please observe the remarks of the standards EN ISO 12100, EN 953 and ISO 14119.



The 3-pole variants can only be connected to 2 screw points. For stability reasons, at least the hatched area shown on the image must be provided as full contact surface.

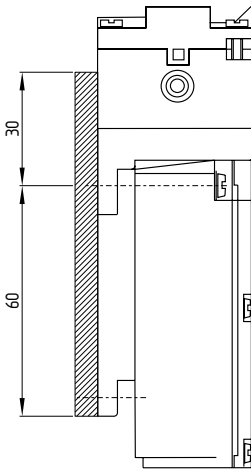

3.2 Dimensions

All measurements in mm.

TZG 2-pole / TZGP

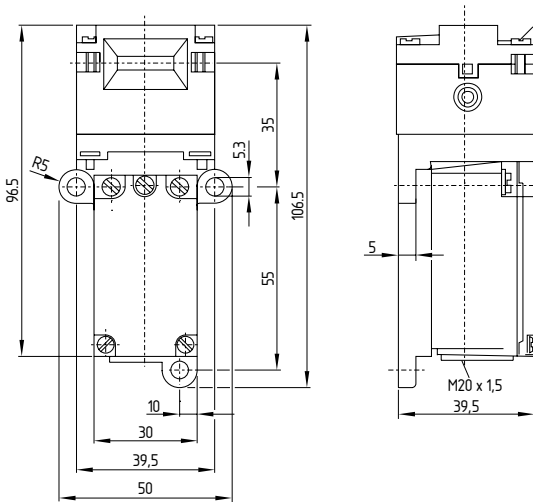

TZG 3-pole

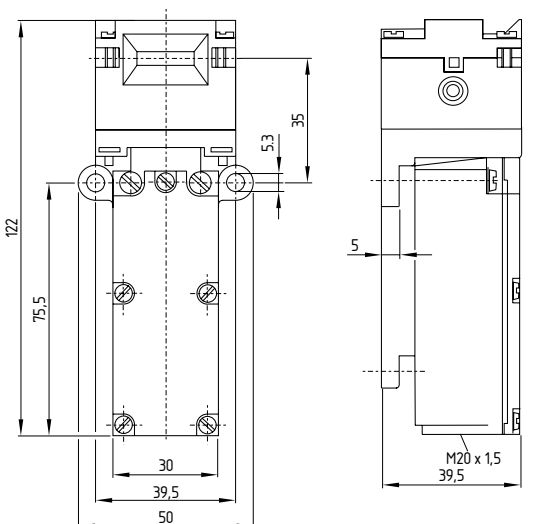

4. Rear side Electrical connection

4.1 General information for electrical connection



The electrical connection may only be carried out by authorised personnel in a de-energised condition.

The contact labelling can be found in the wiring compartment of the switch. For the cable entry, only suitable plastic cable glands with an appropriate degree of protection must be used. After wiring, dust and soiling must be removed from the wiring compartment. The safety switch is double insulated. The use of a protective ground connector therefore is not authorised.

4.2 Contact variants

Contacts are shown with safety guard closed.

TZG../103 / TZGP

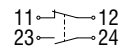

TZG../110

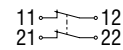

TZG../1103

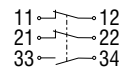

TZG../3330

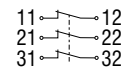

5. Set-up and maintenance

5.1 Functional testing

The safety function of the safety components must be tested. The following conditions must be previously checked and met:

1. Check the free movement of the actuating element.
2. Check the integrity of the cable entry and connections.
3. Check the switch enclosure for damage.

5.2 Maintenance

A regular visual inspection and functional test, including the following steps, is recommended:

1. Check the free movement of the actuating element.
2. Remove particles of dust and soiling.
3. Check cable entry and connections.

Damaged or defective components must be replaced.

6. Disassembly and disposal

6.1 Disassembly

The safety switchgear must be disassembled in a de-energised condition only.

6.2 Disposal

The safety switchgear must be disposed of in an appropriate manner in accordance with the national prescriptions and legislations.

7. EU Declaration of conformity

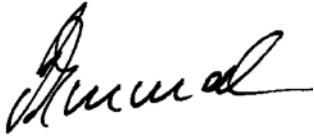
EU Declaration of conformity		
Original	K.A. Schmersal GmbH & Co. KG Möddinghofe 30 42279 Wuppertal Germany Internet: www.schmersal.com	
We hereby certify that the hereafter described components both in their basic design and construction conform to the applicable European Directives.		
Name of the component:	TZG	
Type:	See ordering code	
Description of the component:	Positive break position switch with separate actuator for safety functions	
Relevant Directives:	Machinery Directive RoHS-Directive	2006/42/EC 2011/65/EU
Applied standards:	DIN EN 60947-5-1:2010, DIN EN ISO 14119:2014	
Person authorised for the compilation of the technical documentation:	Oliver Wacker Möddinghofe 30 42279 Wuppertal	
Place and date of issue:	Wuppertal, November 6, 2017	
		
	Authorised signature Philip Schmersal Managing Director	

TZG-E-EN



The currently valid declaration of conformity can be downloaded from the internet at www.schmersal.net.



K. A. Schmersal GmbH & Co. KG
Möddinghofe 30, D - 42279 Wuppertal
Postfach 24 02 63, D - 42232 Wuppertal

Phone: +49 - (0)2 02 - 64 74 - 0
Telefax: +49 - (0)2 02 - 64 74 - 1 00
E-Mail: info@schmersal.com
Internet: <http://www.schmersal.com>

Operating instructions

Safety switch

System components

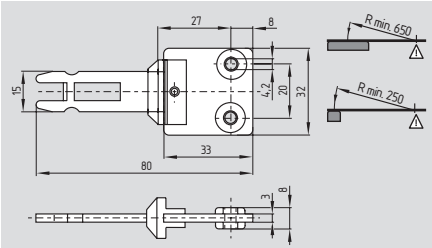

Straight actuator TZ/CO

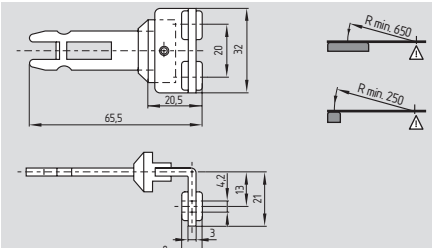

Angled actuator TZ/CW

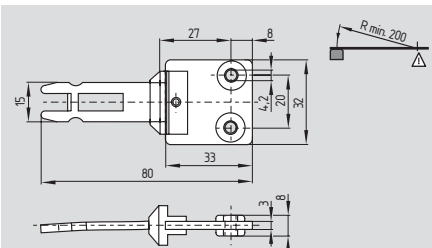

Straight radius actuator TZ/COR

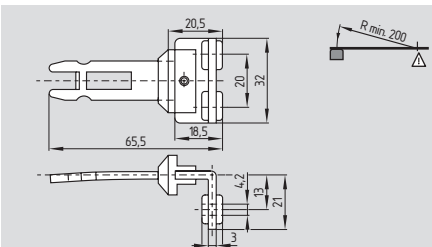

Angled radius actuator TZ/CWR

System components

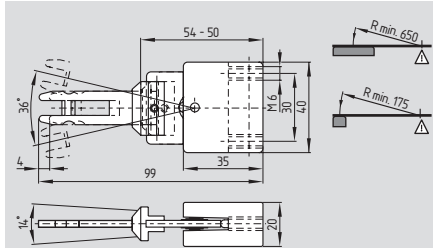

Flexible actuator TZ/COF/HIS.1

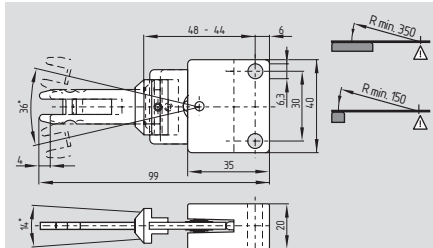

Flexible actuator TZ/COF/HIS.2

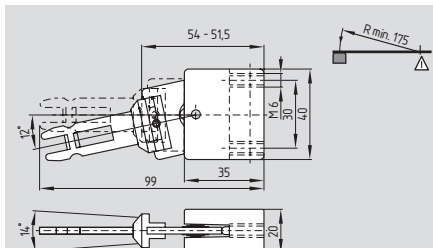

Flexible actuator TZ/CORF/HIS.1

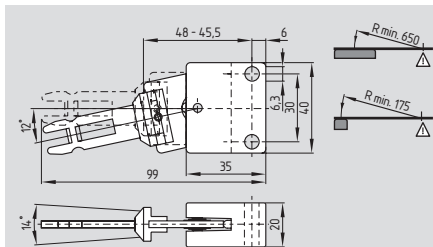

Flexible actuator TZ/CORF/HIS.2

System components

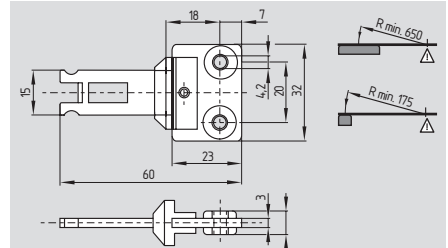

Shortened straight actuator TZ/CK

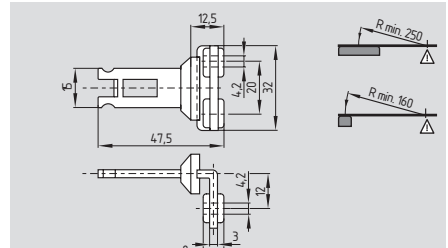

Shortened angled actuator TZ/CWK

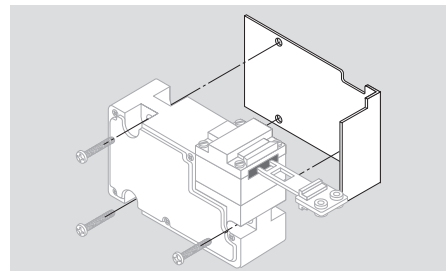

Mounting plate TZ-44

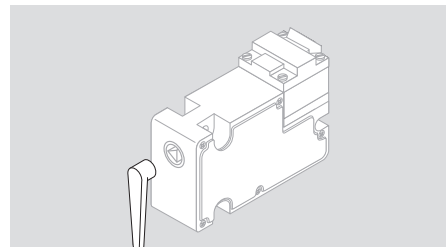

Angled triangular key TZ-75

Ordering details

Straight actuator **TZ/CO**
 Angled actuator **TZ/CW**
 Straight radius actuator **TZ/COR**
 Angled radius actuator **TZ/CWR**

Ordering details

Flexible actuator **TZ/COF/HIS.1**
 Flexible actuator **TZ/COF/HIS.2**
 Flexible actuator **TZ/CORF/HIS.1**
 Flexible actuator **TZ/CORF/HIS.2**

Ordering details

Shortened straight actuator **TZ/CK**
 Shortened angled actuator **TZ/CWK**
 Mounting plate **TZ-44**
 Triangular key **TZ-75**
 (TZ-69 triangular key is included in delivery for S and N executions)