



**EN** Operating instructions . . . . . pages 1 bis 6  
Original

Content	
<b>1</b>	<b>About this document</b>
1.1	Function . . . . . 1
1.2	Target group: authorised qualified personnel. . . . . 1
1.3	Explanation of the symbols used . . . . . 1
1.4	Appropriate use . . . . . 1
1.5	General safety instructions . . . . . 1
1.6	Warning about misuse . . . . . 1
1.7	Exclusion of liability . . . . . 2
<b>2</b>	<b>Product description</b>
2.1	Ordering code . . . . . 2
2.2	Special versions. . . . . 2
2.3	Purpose . . . . . 2
2.4	Technical data . . . . . 2
2.5	Safety classification of the safety function . . . . . 3
<b>3</b>	<b>Mounting</b>
3.1	General mounting instructions . . . . . 3
3.2	Dimensions . . . . . 3
3.3	Mounting of the control panel. . . . . 3
3.4	Inscription plates . . . . . 3
3.5	Mounting of the pushbutton and illuminated pushbutton caps for option -2875. . . . . 4
<b>4</b>	<b>Electrical connection</b>
4.1	General information for electrical connection. . . . . 4
<b>5</b>	<b>Functions and configuration</b>
5.1	Positions of the actuating elements . . . . . 4
5.2	Safety function . . . . . 4
5.3	Configuration of the safety monitor . . . . . 4
5.4	Function of the command and signalling devices . . . . . 5
5.5	Programming the slave address . . . . . 5
5.6	Status signal "safety release" . . . . . 5
<b>6</b>	<b>Set-up and maintenance</b>
6.1	Functional testing. . . . . 5
6.2	Maintenance . . . . . 5
<b>7</b>	<b>Disassembly and disposal</b>
7.1	Disassembly. . . . . 5
7.2	Disposal . . . . . 5
<b>8</b>	<b>EU Declaration of conformity</b>

**1. About this document**

**1.1 Function**  
This operating instructions manual provides all the information you need for the mounting, set-up and commissioning to ensure the safe operation and disassembly of the switchgear. The operating instructions must be available in a legible condition and a complete version in the vicinity of the device.

**1.2 Target group: authorised qualified personnel**  
All operations described in this operating instructions manual must be carried out by trained specialist personnel, authorised by the plant operator only.

Please make sure that you have read and understood these operating instructions and that you know all applicable legislations regarding occupational safety and accident prevention prior to installation and putting the component into operation.

The machine builder must carefully select the harmonised standards to be complied with as well as other technical specifications for the selection, mounting and integration of the components.

**1.3 Explanation of the symbols used**

 **Information, hint, note:**  
This symbol indicates useful additional information.

 **Caution:** Failure to comply with this warning notice could lead to failures or malfunctions.  
**Warning:** Failure to comply with this warning notice could lead to physical injury and/or damage to the machine.

**1.4 Appropriate use**  
The Schmersal range of products is not intended for private consumers.

The products described in these operating instructions are developed to execute safety-related functions as part of an entire plant or machine. It is the responsibility of the manufacturer of a machine or plant to ensure the correct functionality of the entire machine or plant.

The safety switchgear must be exclusively used in accordance with the versions listed below or for the applications authorised by the manufacturer. Detailed information regarding the range of applications can be found in the chapter "Product description".

**1.5 General safety instructions**  
The user must observe the safety instructions in this operating instructions manual, the country specific installation standards as well as all prevailing safety regulations and accident prevention rules.

 Further technical information can be found in the Schmersal catalogues or in the online catalogue on the Internet: [products.schmersal.com](https://products.schmersal.com).

The information contained in this operating instructions manual is provided without liability and is subject to technical modifications.

There are no residual risks, provided that the safety instructions as well as the instructions regarding mounting, commissioning, operation and maintenance are observed.

**1.6 Warning about misuse**

 In case of improper use or manipulation of the safety switchgear, personal hazards or damages to machinery or plant components cannot be excluded.

x.000 / 08.2024 / v.A. - 101214289 / F / 2024-08-05 / AE-Nr.: 18238

### 1.7 Exclusion of liability

We shall accept no liability for damages or malfunctions resulting from defective mounting or failure to comply with this operating instructions manual. We shall accept no liability for damages or malfunctions resulting from defective mounting or failure to comply with this operating instructions manual.

For safety reasons, invasive work on the device as well as arbitrary repairs, conversions and modifications to the device are strictly forbidden, the manufacturer shall accept no liability for damages resulting from such invasive work, arbitrary repairs, conversions and/or modifications to the device.

## 2. Product description

### 2.1 Ordering code

This operating instructions manual applies to the following types:

**BDF200** ①-AS ②-③-④-⑤-⑥-⑦

No.	Option	Description
①	ST1	Connector plug M12, bottom
	ST2	Connector plug M12, top (not for option G24)
②	<b>Pos. 1</b>	<b>Command device</b>
	NH	Emergency stop without protective collar
③	NHK	Emergency stop latching pushbutton with protective collar
	DT..	Push buttons
	PT..	Mushroom push button
	B	Blanking plug
	<b>Pos. 2</b>	<b>Command and signalling device:</b>
	WS 2 / 3..	Maintained selector switch, 2 or 3 positions
	WT. 2 / 3..	Maintained spring-return rotary selector switch, 2 or 3 positions
	SWS / SWT 20	Key-operated selector switch 2 positions
	LT..	Illuminated pushbutton
	LM..	Indicator lights
④	DT..	Push buttons
	PT..	Mushroom push button
	B	Blanking plug
	<b>Pos. 3</b>	<b>Command and signalling device:</b>
	LT..	Illuminated pushbutton
	LM..	Indicator lights
	DT..	Push buttons
	PT..	Mushroom push button
	B	Blanking plug
	⑤	<b>Pos. 4</b>
LT..		Illuminated pushbutton
LM..		Indicator lights
DT..		Push buttons
PT..		Mushroom push button
⑥	B	Blanking plug
		Without indicator lamp
	G24	Indicator lamp G24, red/green
	G24R/B	Indicator lamp G24, red/blue
⑦	G24Y	Indicator lamp G24, yellow
	2875	Pushbutton caps for pushbuttons and illuminated pushbuttons included in the kit



The unused positions 1 - 4 are labelled "B" and are sealed with a blanking plug in factory. The operating elements can only be retrofitted at the factory.



Only if the information described in this operating instructions manual are followed correctly, the safety function and therefore the compliance with the Machinery Directive is maintained.

### 2.2 Special versions

For special versions, which are not listed in the ordering code below 2.1, these specifications apply accordingly, provided that they correspond to the standard version.

### 2.3 Purpose

The modular BDF200AS control panel is installed on the safety guard of a machine or plant. It enables the operator to activate for instance the emergency stop, start/stop and reset functions.

The emergency stop command device is used on machinery and plants as a safe command device to generate a safe signal initiating the shutdown of a hazardous movement when actuated.

The emergency stop command device must only be used in combination with the AS-i safety monitor.

The integrated AS-i safety module is used to detect safety-relevant switching conditions of mechanical contacts.

An AS-Interface Safety at Work component functions on the basis of an individual code generator (8 x 4 bit). This safety code is cyclically transmitted over the AS-i network and monitored by the safety monitor.



The user must evaluate and design the safety chain in accordance with the relevant standards and the required safety level.



**Maintenance:** Please observe that the safety function must be triggered at least once a year to test the system!

### 2.4 Technical data

Standards:	EN 60947-5-1, EN 60947-5-5, EN ISO 13850, EN 62026-2 EN ISO 13849-1, EN 61508
Enclosure:	glass-fibre reinforced thermoplastic, self-extinguishing
Mechanical life:	command devices: 1 million operations Rotary switch: 30,000 operations Emergency stop: 100,000 operations
Response time:	< 100 ms
Connection:	Connector plug M12, 4-pole,
Lamp socket:	BA5S, only LED, max. length 17 mm
LED change:	from front
<b>Electrical data - AS-Interface:</b>	
AS-i supply voltage:	18,0 ... 31,6 VDC through AS-Interface, reverse polarity-proof (stabilised PELV units)
AS-I power consumption:	≤ 150 mA
AS-i Device insulation:	internal short-circuit proof
<b>AS-i specification Safety-Slave:</b>	
Version:	V 3.0
Profile:	S--7.B.F.F
IO-Code:	0x7
ID-Code:	0xB
ID-Code 1:	0xF
ID-Code 2:	0xF
AS-interface inputs:	
Channel 1:	DI 0 / DI 1 = dynamic code transmission
Channel 2:	DI 2 / DI 3 = dynamic code transmission
AS-interface outputs:	
DO 0	Indicator lamp G24 red (yellow for G24Y)
DO 1	Indicator lamp G24 green (blue for G24R/B)
DO 2 ... DO 3	not used
AS-Interface parameter port:	P0 ... P3: not used
<b>AS-i specification A/B-Slave:</b>	
Version:	V 3.0
Profile:	S-7.A.7.E
IO-Code:	0x7
ID-Code:	0xA
ID-Code 1:	0x7
ID-Code 2:	0xE

### AS-interface inputs:

DI 0	button Pos. 4
DI 1	button Pos. 3
DI 2	button / switch Pos. 2
DI 3	button / switch Pos. 2

### AS-interface outputs:

DO 0	light element Pos. 4
DO 1	light element Pos. 3
DO 2	light element Pos. 2
DO 3	not used

AS-Interface parameter port: P0 ... P3: not used  
 Input module address: 0,  
 preset to address 0,  
 can be changed through AS-interface bus master  
 or hand-held programming device

### Ambient conditions:

Ambient temperature:	-25 °C ... +65 °C
Storage and transport temperature:	-25 °C ... +85 °C
Climatic resistance:	to EN 60068 part 2 - 30
Degree of protection:	IP65
Protection class:	II □
Resistance to vibration:	10 ... 150 Hz (0.35 mm / 5 g)
Resistance to shock:	15 g / 11 ms
Overvoltage category:	III
Degree of pollution:	3
Rated impulse withstand voltage $U_{imp}$ :	800 V
Rated insulation voltage $U_i$ :	32 VDC



Only for use in Pollution Degree 2 Environment.  
 For use in NFPA 79 Applications only.  
 Adapters providing field wiring means are available  
 from the manufacturer.  
 Refer to manufacturer's information.

### 2.5 Safety classification of the safety function

Standards:	EN ISO 13849-1, EN 61508
PL:	up to e
Category:	4
PFH:	$\leq 1,4 \times 10^{-8}$ / h up to max. 5.000 switching cycles/year
SIL:	up to 3
Mission time:	20 years

## 3. Mounting

### 3.1 General mounting instructions

For the correct fixing of the BDF200AS control panel, the device is provided with two mounting holes for M5 screws which are provided. Any position is possible.



The relevant requirements of the standard EN ISO 12100 must be observed.

### 3.2 Dimensions

All measurements in mm.

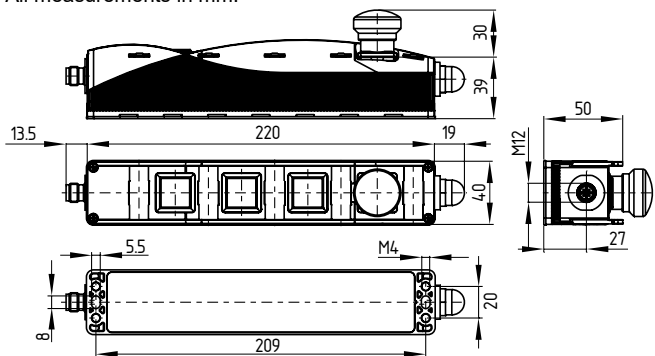

### 3.3 Mounting of the control panel

Remove the cover of the enclosure a and b (screws: Torx 10).



When opening the enclosure cover, please avoid damage to the connecting cables.



**Caution!**  
 Electrostatically sensitive components.  
 Do not touch the printed circuit board.

Use 2 x M5 cylindrical screws ISO 4762 (DIN 912) for the assembly.



When closing the enclosure cover, please observe that the individual cables are not caught between the command device and the contact element.

After fitting, the cover screws must be tightened with a tightening torque of 0.7 ... 0.8 Nm.

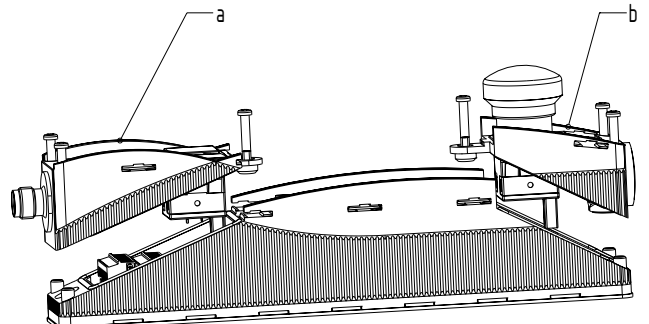

When closing the enclosure cover, ensure that the emergency stop module is flush with the bottom section and that the cover screws are screwed in as far as they will go. The emergency stop safety function must be checked by an appointed safety technician / safety representative once successfully installed.

### 3.4 Inscription plates

The marking on the inscription plates (included in delivery) is carried out by colour change by laser. The effects of heat may change the colour of the surface.

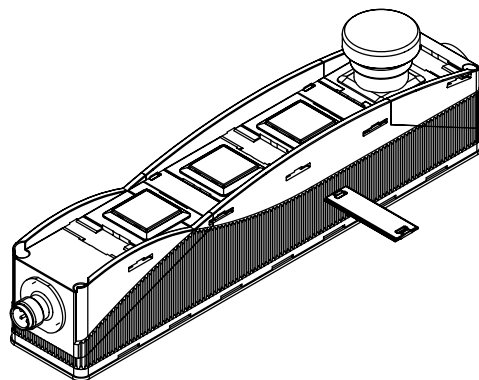

It must be ensured that the top is inscribed.

### 3.5 Mounting of the pushbutton and illuminated pushbutton caps for option -2875



The caps for the pushbuttons and illuminated pushbuttons are only suitable for a one-time mounting. Disassembly of the caps could cause damages to the component. The caps must be mounted immediately after unpacking the control panel, in order to avoid soiling of the inner pushbutton compartment by gross dirt particles / dust.

The caps for the pushbuttons and illuminated pushbuttons are mounted in the following manner:

1. Take the pushbutton or illuminated pushbutton cap as well as the rubber disk out of the kit
2. Take the control panel out of the protective packaging
3. Place the rubber disk on the pushbutton surface
4. Install the pushbutton or illuminated pushbutton cap onto that
5. Fix the cap



The cap "clicks" when it is engaged

6. Check the smooth actuation of the pushbutton
7. Repeat this procedure for all other pushbuttons



After the pushbutton or illuminated pushbutton cap is mounted, the proper fitting and the smooth actuation of the pushbutton must be checked. The button must return autonomously from the actuated to the non-actuated state and the cap must be at the same height as the component edging.

## 4. Electrical connection

### 4.1 General information for electrical connection



The electrical connection may only be carried out by authorised personnel in a de-energised condition.

The AS-i Safety Slave with safety function and the AS-i A/B Slave with the functions of the command and signalling devices are supplied by the AS-Interface cable.

The connection to the AS-Interface system is realised through an M12 connector. The connector is A-coded, the wiring configuration is determined as follows (to EN 62026-2).

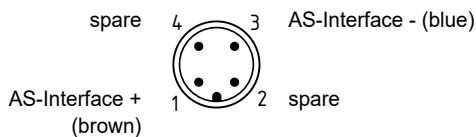

## 5. Functions and configuration

### 5.1 Positions of the actuating elements

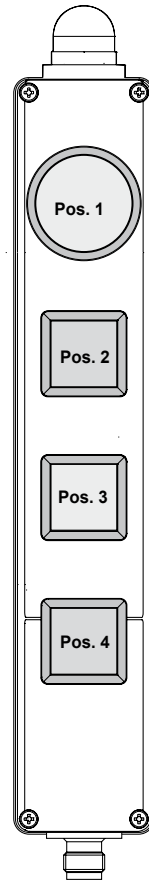

#### optional:

- G24 indicator lamp red / green
- G24 indicator lamp red / blue
- G24 indicator lamp yellow

#### Position 1:

- NH, emergency stop impact button
- NHK, Emergency stop with protective collar
- Pushbutton DT
- Mushroom push button PT

#### Position 2:

- Illuminated pushbutton LT
- Illuminated signal LM
- Pushbutton DT
- Mushroom push button PT
- WS2./ WT2., selector switch / button, 2 positions
- WS3./ WT3., selector switch / button, 3 positions
- SWS / SWT 20 Key switch/button, 2 switch positions

#### Position 3 and position 4:

- Illuminated pushbutton LT
- Illuminated signal LM
- Pushbutton DT
- Mushroom push button PT

### 5.2 Safety function

#### Position 1: Safety function and indicator lamp

NH, NHK, DT, PT, G24

- |                   |               |                           |
|-------------------|---------------|---------------------------|
| • Emergency stop  | DI 0 ... DI 3 | dynamic code transmission |
| • Safety function | DI 0 ... DI 3 | dynamic code transmission |
| • Indicator lamp  | DO 0          | G24 red LED               |
|                   |               | G24R/B red LED            |
|                   |               | G24Y LED yellow           |
| • Indicator lamp  | DO 1          | G24 LED green             |
|                   |               | G24R/B LED blue           |

### 5.3 Configuration of the safety monitor

The safety function of the BDF200AS can be configured in the ASIMON configuration software with the following monitoring devices. (also refer to the ASIMON manual)

#### Double channel forced

- Optionally with startup test
- Optional with local acknowledge



The configuration of the safety monitor must be tested and confirmed by a qualified and authorised safety expert/safety engineer.

### 5.4 Function of the command and signalling devices

#### Position 2: AS-i A/B-Slave

Maintained selector switch / spring-return selector switch, 2 positions:

WS20, WT20, SWS20, SWT20

- Position 0 ---
- Position 1 DI 2 and DI 3



Maintained selector switch / spring-return selector switch, 3 positions:

WS30, WT30, WTS30

- Position 1 DI 3
- Position 0 ---
- Position 2 DI 2

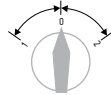

WTS30: position 1 = latching; position 2 = pushbutton function

Illuminated pushbutton, pushbutton, indicator light and mushroom pushbutton:

LT., DT., LM., PT..

- Pushbutton function DI 2 and DI 3
- Indicator lights DO 2



#### Position 3: AS-i A/B-Slave

Illuminated pushbutton, pushbutton, indicator light and mushroom pushbutton:

LT., DT., LM., PT..

- Pushbutton function DI 1
- Indicator lights DO 1



#### Position 4: AS-i A/B-Slave

Illuminated pushbutton, pushbutton, indicator light and mushroom pushbutton:

LT., DT., LM., PT..

- Pushbutton function DI 0
- Indicator lights DO 0



### 5.5 Programming the slave address

The slave addresses for both integrated AS-i slaves are programmed through the M12 connector.

To that effect the lower enclosure cover must be opened. By means of the there-located DIP switches, both AS-i slaves can be individually separated from or connected to the AS-i connection.

- DIP-SW 1 AS-i A/B-Slave
- DIP-SW 2 AS-i Safety-Slave

For the AS-i Safety-Slave an address from 1 to 31 and for the AS-i A/B slave an address from 1A to 31B can be set by means of an AS-i bus master or a hand-held programming device.

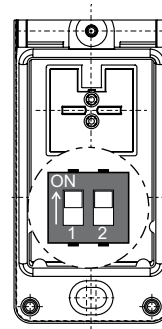

DIP-SW 1: AS-i A/B-Slave

DIP-SW 2: AS-i Safety-Slave



#### Caution!

Electrostatically sensitive components.  
Do not touch the printed circuit board.

### 5.6 Status signal "safety release"

The "safety release" status signal from a Safety at Work slave can be cyclically queried by the control system through the AS-i master. To this effect, the 4 input bits with the varying SaW code of a Safety at Work slave are evaluated through an OR operation with 4 inputs in the control system.

## 6. Set-up and maintenance

### 6.1 Functional testing

The safety function of the safety components must be tested.

The following conditions must be checked and met:

- Correct fixing of the fitted component
- Check the integrity of the cables and connections
- Check the command and signalling devices for damage
- For the types with extension ...-2875, the proper fitting and the smooth operation of the pushbuttons must be checked after the installation of the pushbutton and illuminated pushbutton caps

### 6.2 Maintenance

The function of the emergency stop button must be tested in regular intervals.



**Maintenance:** Please observe that the safety function must be triggered at least once a year to test the system!

In case of correct installation in accordance with the instructions described above, the component requires little maintenance. Under extreme conditions, we recommend routine maintenance as follows:

- Check the correct fixing of the control panel
- Remove particles of dust and soiling.
- Check the integrity of the cables and connections
- For the types with extension ...-2875, the smooth operation of the pushbuttons and the illuminated pushbuttons must be checked.

**Damaged or defective components must be replaced.**

## 7. Disassembly and disposal

### 7.1 Disassembly

The safety switchgear must be disassembled in a de-energised condition only.

### 7.2 Disposal

The safety switchgear must be disposed of in an appropriate manner in accordance with the national prescriptions and legislations.

8. EU Declaration of conformity

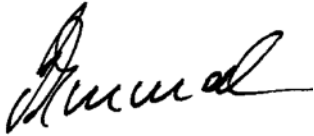
<b>EU Declaration of conformity</b>		
Original	K.A. Schmersal GmbH & Co. KG Möddinghofe 30 42279 Wuppertal Germany Internet: www.schmersal.com	
We hereby certify that the hereafter described components both in their basic design and construction conform to the applicable European Directives.		
<b>Name of the component:</b>	BDF200AS	
<b>Type:</b>	see ordering code	
<b>Description of the component:</b>	Control panel with or without safety function and integrated AS interface	
<b>Relevant Directives:</b>	Machinery Directive <sup>1)</sup> Low Voltage Directive EMC-Directive RoHS-Directive <sup>1)</sup> for device versions with safety function	2006/42/EC 2014/35/EU 2014/30/EU 2011/65/EU
<b>Applied standards:</b>	EN 60947-5-1:2017 + AC:2020 <sup>1)</sup> EN 60947-5-5:1997 + A1:2005 + A11:2013 + A2:2017 <sup>1)</sup> EN ISO 13849-1:2023 <sup>1)</sup> EN 61508-1:2010	
<b><sup>1)</sup> Notified body for Type Examination:</b>	TÜV Rheinland Industrie Service GmbH Am Grauen Stein 51105 Köln ID n°: 0035	
<b><sup>1)</sup> EC-Type Examination Certificate:</b>	01/205/5613.01/24	
<b>Person authorised for the compilation of the technical documentation:</b>	Oliver Wacker Möddinghofe 30 42279 Wuppertal	
<b>Place and date of issue:</b>	Wuppertal, 24. June 2024	
BDF200AS-E-EN		
	Authorised signature <b>Philip Schmersal</b> Managing Director	



The currently valid declaration of conformity can be downloaded from the internet at [products.schmersal.com](http://products.schmersal.com).

