

Product information

OPTOELECTRONIC SAFETY GUARDS



SCHMERSAL
THE DNA OF SAFETY

INTRODUCTION



Heinz and Philip Schmersal,
Managing Directors of the Schmersal Group

New solutions to improve production efficiency and machine safety

Safety in system – Protection for man and machine

Often, it is unavoidable that people have to intervene with the workings of a machine. When this is done, the safety of the operator is imperative. This demands the responsibility of the machine operator, which is also required by the world's standards and guidelines for machine safety.

The Schmersal Group has concentrated for many years on safety at work with our products and solutions; today we can offer the industry the world's largest range of safety switchgear and systems for the protection of man and machine.

Under the guiding principle "Safety with system – protection for man and machine" we develop and produce products that carry the system concept and can be optimally integrated into the work processes. Because we are convinced that safety does not contradict higher productivity.

In our fields of activity we have a leading position due to our expertise, our innovative power and our comprehensive range of products. With this we follow a central theme: Together with you, we want to make the world safer.

Talk to us – we look forward to working with you.

Introduction _____	Page 2
Description _____	Page 4
Modes of operation and functions _____	Page 6
Safety distance _____	Page 8
Overview _____	Page 9
Safety light barriers _____	Page 10
Overview _____	Page 10
Preferred types and accessories _____	Page 12
Safety light grids / light curtains Type 2 _____	Page 14
Series SLC/SLG 240 _____	Page 14
Safety light grids / light curtains Type 4 _____	Page 16
Series SLC/SLG 440COM/440/445 _____	Page 16
Overview _____	Page 16
Preferred types _____	Page 18
EX Safety light grids / light curtains Type 4 _____	Page 20
Overview _____	Page 20
Preferred types _____	Page 21
Safety monitoring modules _____	Page 22
Accessories _____	Page 24
tec.nicum _____	Page 28

Web shop



Already familiar with our new web shop?
Here you will find all details and data
on our products which you can order
directly online:

products.schmersal.com

OPTOELECTRONIC SAFETY DEVICES

DESCRIPTION

USAGE / SELECTION OF AOPD

In order to choose the appropriate active optoelectronic protective device (AOPD) such as light barriers or light curtains/grids to use them correctly, both the requirements of the standards (EN ISO 13849-1, EN ISO 13855, C standards etc.) and product-specific features (detection sensitivity, range, etc.) must be taken into account.

AOPD's can be used, provided that:

- The dangerous movement can be stopped at all times and that it is ensured that the dangerous area can only be reached after the movement has come to standstill.
- The stopping time for the machine and all safety components used are known.
- No objects (work pieces, liquids, etc.) can be ejected.
- The AOPD meet the requirements of Type 2 or Type 4 acc. to EN 61496.
- The dangerous area can only be reached by passing through the protected field of the AOPD.
- Reaching over, under or through the protected field is impossible.
- The start or restart command devices are fitted in such a way that the entire hazardous area is completely visible from the outside and it cannot be activated from within the hazardous area.
- The safety distance is calculated and constructively applied in accordance with EN ISO 13855.

The effectiveness of the protection equipment is only as good as the risk analysis carried out when designing the system, which took into consideration all the marginal conditions such as surroundings, machine and functional sequences.

SAFETY LIGHT GRIDS / LIGHT CURTAINS

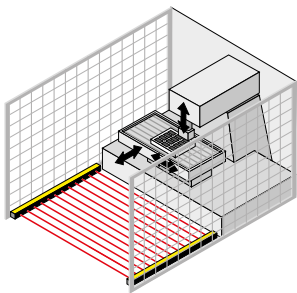

The safety light curtains and safety light grids of the SLC and SLG range meet the requirements of Category type 2 and type 4 according to EN 61496. Typical applications for safety light barriers are on robots, automatic-processing plants, transfer lines, rack storage and pallet loaders. If the light beam is interrupted by an object or a person, a stop signal is emitted to bring the machine to a standstill.

The protection field is defined by the height and width of the protection field. The protected height is the range between the first and last infrared light beam of a light curtain. The protected width or operating range is the distance between the emitter and receiver unit. If the light beam is interrupted, a signal is emitted to bring the dangerous movement of the machine to a standstill.

For the detection of body parts, a distinction is made between finger, hand and body protection. EN ISO 13855 sets the biometric data for finger protection to 14 mm, for hand detection to 30 mm, for leg detection up to 70 mm and for body detection to over 70 mm. Safety light grids are generally used to detect the penetration of the entire human body.

The safety light grids and light curtains can be smoothly connected through a M12 connector plug; they are equipped with a diagnostic interface as well as an LED for status indication. The safety light curtains or light grids feature an integrated safety-monitoring module with start/restart interlock and contactor control. Additional functions such as blanking, muting and a synchronisation function for the light curtains are also available. Today with Bluetooth® LE an innovative communication interface is available for the diagnosis and inspection of AOPD. The current AOPD data of the SLC440 and SLC440COM series are displayed in real time.



SAFETY LIGHT CURTAINS WITH BLUETOOTH® INTERFACE BLE

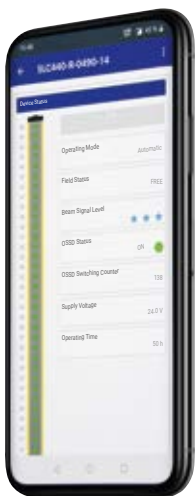

"SLC Assist" for iOS



"SLC Assist" for Android



The App "SLC Assist"

The App gives information about

- Operating mode
- Beam signal level
- OSSD status
- Status of the protective field
- Number of OSSD switches
- Supply voltage
- Operating time

Beam signal level:

★★★ = perfect alignment

☆☆☆ = optimisation required

You will define the service cycles for the safety relay module via the OSSD switching counter. The information of the total operating time is the basis for planning the periodic inspection.

Innovative Technology

The light curtain with Bluetooth® interface and the SCHMERSAL App gives optimal support for

- Condition monitoring
- Optimal alignment
- Preventive maintenance
- Documentation according to industrial safety regulations

The SCHMERSAL App "SLC Assist" is available for Android and iOS devices.

More information can be found in the product video.

Product video:



OPTOELECTRONIC SAFETY DEVICES

MODES OF OPERATION AND FUNCTIONS

SAFETY LIGHT BARRIERS

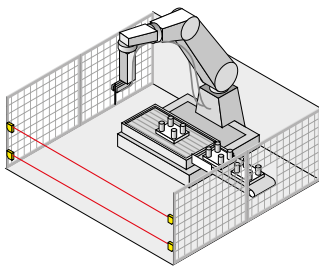

All SLB photoelectric barriers have fail-safe integrated semi-conductor outputs (2 x PNP) and can be incorporated directly in the safety circuit without external safety monitoring. The new product family meets the requirements of all type 2 or type 4 applications in accordance with EN 61496. The safety photoelectric barriers are distinguished by extremely small dimensions which means that they can be well placed in the surrounding structure and can also be mounted easily and quickly even in tight spaces. Both models have a range of 15 metres. The SLB 440...-H model features a range of up to 75 metres and, as an option, has integrated heating for use in minus temperatures.

Single beam photoelectric barriers are particularly suitable for safeguarding smaller hazardous areas – such as machines with small openings or slots.

With this set of features, the new photoelectric barriers can be deployed in numerous ways – for example in work areas where assembly and material handling technology is used as well as in the wood, paper and print industry. Other areas of application are (semi) automated shelving and commissioning systems, high shelf warehouses and packaging machines as well as for confining work areas of man and machine. It can also be used in outside areas, for example in the wood and cement industry, in gravel pits or in harbours/ports.

OPERATING MODES



Double reset

The operating modes of an AOPD must be defined according to the risk analysis of a machine.

Automatic / Protective mode

The protective mode switches the AOPD outputs to an ON state (protection field not interrupted), without external release of a switching device. This mode of operation creates an automatic machine restart if the protection field is not interrupted and should only be selected with the restart interlock of the machine.

Restart interlock (manual reset)

The restart interlock (manual reset) prevents an automatic enabling of the outputs (OSSD's ON state) after switch-on of the operating voltage or an interruption of the protection field. The system switches the outputs only to an ON state, when an external command device generates an enabling signal at the restart input (receiver).

Restart interlock with double acknowledgement/reset

In applications with access monitoring, a complete overview of the hazardous areas is often not possible; despite that, a reset of the command device for the restart interlock outside of the hazardous area by third parties is enabled at all times. This hazardous situation of an unexpected start-up can be avoided by means of a double reset, i.e. integration of one command device inside and one outside the hazardous area.

Setting mode

Before commissioning an AOPD, the best possible alignment of the sensors should be determined. The set-up mode visualises the set-up quality during the installation of the sensors. Visualisation is via a 7-segment display, a status display or optionally via a smartphone with the "SLC Assist" app.



OBJECT BLANKING

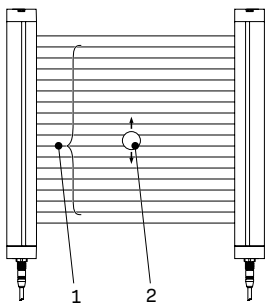

- 1 Object blanking area
- 2 Movable object

For safe production, object blanking can be used to blank just part of the protection field. This makes it possible to add objects, e.g. workpieces, or position a conveyor belt with a fixed position in the protection field.

With integrated movable object blanking (floating blanking) of the SLC440/445 light curtains, up to 2 light beams of the light curtain can be blanked flexibly. This function is required if there is a need to be able to interrupt light beams in the protection field at a position that is not specifically defined.

Different blanking functions are available. The distinguishing feature of the different modes is the number of light beams that can be interrupted by an object. In addition to that, it can be defined whether the object may be in the protection field permanently or only temporarily. The interrupted light beams can be at any position in the protection field.

MUTING

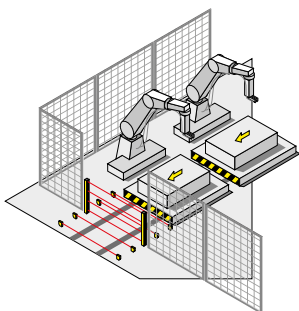

If goods or objects need to be transported in or out of the hazardous area without stopping the machine, the safety light curtain must be automatically and temporarily suspended. Two or four muting signals are used to detect whether a person is approaching the hazardous area or a transport system is entering or leaving the hazardous area. Suitable muting inputs are light barriers, proximity switches or position switches.

The integrated safety-muting controller of the safety light curtain or light grid monitors and controls the muting process. The safety outputs are not disabled. Depending on the application, different light barriers with integrated muting functions are available.

OPTOELECTRONIC SAFETY DEVICES

SAFETY DISTANCE

SAFETY DISTANCE

The stopping time for the complete system and the resolution capacity of the AOPD essentially determines the required safety distance of the AOPD to the dangerous area. The safety light grid or light curtain must be sized and installed so that a stop signal would be transmitted and the hazard ceased prior to a person or a body part accessing the danger zone.

The standard EN ISO 13855 provides the user with detailed information about the calculation of the minimum safety distances. These include the following important influencing factors:

- Stopping time of the entire system, taking the different reaction times of the individual systems into account (e.g. machine, safety relay module, AOPD etc.)
- Detection capability of the AOPD to detect body parts (finger, hand and whole body)
- Arrangement of each protection device in the normal position (vertical mounting), parallel orientation (horizontal mounting) or at any angle in front of the guard system
- Approach speed to the protection field

For the calculation of the minimum safety distance **s** to the hazardous area, EN ISO 13855 presents the following general formula:

$$S = K \times T + C$$

Key:

S the safety distance to the hazardous area (mm)

K the approach speed of the body or the body part (mm/s)

T total reaction time of the system (s)
(inc. machine run-on time, reaction time of the safety guard and the safety relay module, etc.)

C additional distance (mm) before the safety guard

If access to the hazardous area (by passing across the protection field) cannot be excluded by using vertically mounted contactless protective equipment such as a light grid, an additional minimum distance CRO should be considered.

This distance is dependent on the protection field height above the ground and the position of the hazardous area (EN ISO 13855).

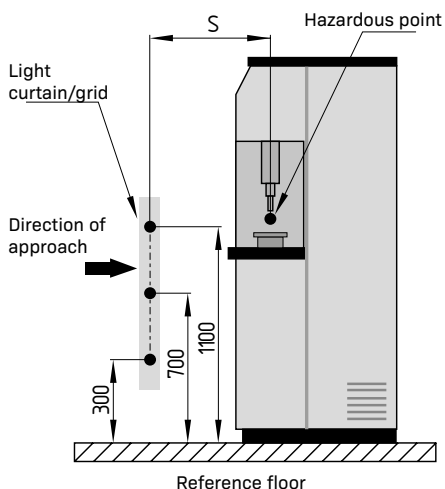

OPTOELECTRONIC SAFETY DEVICES OVERVIEW

Selection	Type to EN 61496	Special features	Series	refer to
Safety light barriers SLB	Type 2	Range to 15 m	SLB240	Page 10
	Type 4	Range to 15 m	SLB440	
		Range to 75 m	SLB440 IP69	
			SLB440-H SLB440-H IP69	
Safety light curtains SLC	Type 2	Compact	SLC240COM	Page 14
	Type 4	Compact	SLC440COM	Page 16
		High degree of protection	SLC440COM – PH enclosure	
		Included in standard version	SLC440	
		High degree of protection	SLC440 – SH/PH enclosure	
		Multifunctional	SLC445	
Ex-Zone 1 and 21	EX-SLC440	Page 20		
Safety light grids SLG	Type 2	Compact	SLG240COM	Page 14
	Type 4	Compact	SLG440COM	Page 16
		High degree of protection	SLG440COM – PH enclosure	
		Included in standard version	SLG440	
		High degree of protection	SLG440 – SH/PH enclosure	
		Multifunctional	SLG445	
Ex-Zone 1 and 21	EX-SLG440	Page 20		

SAFETY LIGHT BARRIERS

RANGE SLB – OVERVIEW



■ SLB240



■ SLB440

Key Features

- Safety light barrier type 2
- 4-stage coding
- Integrated evaluation

- Safety light barrier type 4
- 4-stage coding
- Integrated evaluation

Technical features

Range of the protection field	15 m	15 m
Min. object size	Ø 10 mm	Ø 10 mm
Wave length of the sensors	880 nm	880 nm
Electrical characteristics		
Response time	7 ... 22 ms	7 ... 22 ms
Automatic/restart interlock	■	■
Rated operating voltage U_e	24 VDC ± 10%	24 VDC ± 10%
Safety outputs	2 x OSSD	2 x OSSD
Mechanical data		
Material of the housings	Aluminium	Aluminium
Termination	ST: Connector plug M12 LST: 20 cm Cable with connector M12	ST: Connector plug M12 LST: 20 cm Cable with connector M12
Connector plug (transmitter/receiver)	4-pole / 5-pole	4-pole / 5-pole
Cable length	Max. 100 m	Max. 100 m
Dimensions (H x W x L)	ST: 28 x 91 x 33 mm LST: 28 x 72 x 33 mm	ST: 28 x 91 x 33 mm LST: 28 x 72 x 33 mm
Ambient conditions		
Ambient temperature	-30 °C ... +50 °C	-30 °C ... +50 °C
Degree of protection	IP67	IP67
Recommended safety-monitoring module for the series wiring	SRB-E-204ST	SRB-E-204ST

Safety classification

Standards	EN ISO 13849-1 EN 62061	EN ISO 13849-1 EN 62061
PL/SIL	c/2	e/3
Control category	2	4
PFH	$1.5 \times 10^{-8} / h$	$1.5 \times 10^{-8} / h$
Certificates	TÜV, UL	TÜV, UL



To get detailed information about the products and certificates, visit products.schmersal.com.



■ SLB440-H



■ SLB440(-H) IP69

- Safety light barrier type 4
- 4-stage coding
- Integrated evaluation
- Optional heater





- Safety light barrier type 4
- Hygiene-compliant protective enclosure
- 4-stage coding
- Integrated evaluation

75 m	15 / 75 m
Ø 70 mm	Ø 10 / 70 mm
880 nm	880 nm
7 ... 22 ms	7 ... 22 ms
■	■
24 VDC ± 10%	24 VDC ± 10%
2 x OSSD	2 x OSSD
Aluminium	Polycarbonate / Stainless steel
ST: Connector plug M12 LST: 20 cm Cable with connector M12	LST: 20 cm Cable with connector M12
4-pole / 5-pole	4-pole / 5-pole
Max. 100 m	Max. 100 m
ST: 28 x 131 x 33 mm LST: 28 x 111 x 33 mm	62 x 115 mm 62 x 155 mm (-H)
-30 °C ... +50 °C	-30 °C ... +50 °C
IP67	IP69
SRB-E-204ST	SRB-E-204ST



EN ISO 13849-1 EN 62061	EN ISO 13849-1 EN 62061
e/3	e/3
4	4
1.5 x 10 ⁻⁸ /h	1.5 x 10 ⁻⁸ /h
TÜV, UL	TÜV, UL

SAFETY LIGHT BARRIERS

RANGE SLB – PREFERRED TYPES AND ACCESSORIES

Type	Range	Type	Termination	Type	Material number	
Safety light barriers	SLB240		Coding 1*	Connector plug	SLB240-ER-1-ST	103013801
				Cable with connector	SLB240-ER-1-LST	103013529
	SLB440		Coding 1*	Connector plug	SLB440-ER-1-ST	103019521
				Cable with connector	SLB440-ER-1-LST	103013525
	SLB440-H		Coding 1*	Connector plug	SLB440-ER-1-ST-H	103015483
				Cable with connector	SLB440-ER-1-LST-H	103015487
				Connector plug	SLB440-ER-1-ST-H-EH	103015491
				Cable with connector	SLB440-ER-1-LST-H-EH	103015497
	SLB440(-H) IP69		Coding 1*	Cable with connector	SLB440-ER-1-LST-1047	103041245
				Cable with connector	SLB440-ER-1-LST-H-1047	103041248

*Other coding available.

Connector plug	Parametrisation cable KA-0977 103013625	Mounting kits MS-...
 <ul style="list-style-type: none"> Connector plug M12, straight, 4 pole <ul style="list-style-type: none"> 5 m KA-0804 10 m KA-0805 20 m KA-0808 Connector plug M12, straight, 5 pole <ul style="list-style-type: none"> 5 m A-K5P-M12-S-G-5M-BK-2-X-A-4-69 10 m A-K5P-M12-S-G-10M-BK-2-X-A-4-69 15 m A-K5P-M12-S-G-15M-BK-2-X-A-4-69 	 <ul style="list-style-type: none"> Parametrisation cable for SLB series Y-splitter, M12, 5-pole with P-button 	 <ul style="list-style-type: none"> Assembly sets for SLB series <ul style="list-style-type: none"> For SLB240 / SLB440 (qty. 2 brackets, qty. 4 screws) MS-1101 For SLB440-H (qty. 4 brackets, qty. 8 screws) MS-1100

Detailed information for the selection of accessories can be found at products.schmersal.com.

UP-TO-DATE WITHOUT FAIL ONLINE PRODUCT CATALOGUE



FOR DETAILED INFORMATION, CHECK OUT
[PRODUCTS.SCHMERSAL.COM](https://products.schmersal.com)

SAFETY LIGHT GRIDS AND CURTAINS

TYPE 2 – RANGE 240COM – OVERVIEW



■ SLC240COM



■ SLG240COM

Key Features

- Safety light curtain
- Compact

- Safety light grid
- Compact

Technical features

Resolution	14, 30, 35 mm	300, 400 or 500 mm
Protection heights	330 mm ... 1930 mm	500, 800 or 900 mm
Number of beams	11 ... 192	2, 3 or 4 beams
Range of the protection field	0.3 ... 12 m	0.3 ... 12 m
Operating modes		
- Protective mode / Automatic	■	■
- Restart interlock (manual reset)	■	■
- Parameter setting	KA-0896	KA-0896
Functions integrated		
- Contactor control	-	-
- Blanking of objects	■	■
- Muting	-	-
- Cyclic function	-	-
- Further functions (see key)	DM, RS	DM, RS
Electrical characteristics		
Operating voltage	24 VDC ± 10%	24 VDC ± 10%
Safety output OSSD, 24 VDC	2 x PNP (timing)	2 x PNP (timing)
Response time OSSD	10 ... 28 ms	10 ms
Switching capacity OSSD	500 mA	500 mA
LED status display, 7-segment display	Status display	Status display
Mechanical data		
Execution of the electrical connection	Connector plug	Connector plug
Connector plug (transmitter/receiver)	4-pole / 5-pole	4-pole / 5-pole
Dimensions ¹⁾	27.8 x 33 mm	27.8 x 33 mm
Ambient conditions		
Ambient temperature	-10 °C ... +50 °C	-10 °C ... +50 °C
Degree of protection	IP67	IP67

Safety classification

Standards	EN ISO 13849-1, EN 62061	EN ISO 13849-1, EN 62061
PL/SIL	c/1	c/1
Control category	2	2
PFH	8.05 x 10 ⁻⁹ /h	8.05 x 10 ⁻⁹ /h
Certificates	TÜV, UL, EAC	TÜV, UL, EAC



Type to EN 61496	Type	Range	Resolution	Protection heights	Range	Type	Material number
Type 2	Safety light curtain SLC	SLC240COM	14 mm	330 ... 1930 mm	0,3 ... 7 m	SLC240COM-ER-xxxx-14	---
			30 mm	330 ... 1930 mm	0.3 ... 12 m	SLC240COM-ER-xxxx-30	---
			35 mm	330 ... 1930 mm	0,3 ... 7 m	SLC240COM-ER-xxxx-35	---
	Safety light grids SLG	SLG240COM	2 beams	500 mm	0.3 ... 12 m	SLG240COM-ER-0500-02	103016120
			3 beams	800 mm	0.3 ... 12 m	SLG240COM-ER-0800-03	103016122
			4 beams	900 mm	0.3 ... 12 m	SLG240COM-ER-0900-04	103016127

xxxx = For different heights and other combinations, see products.schmersal.com.

--- = The material number is dependent on the protective field heights.

¹⁾ The height depends on the protection field height

Key

BC = Beam coding
DQ = Double acknowledgement/reset
MS = Multiple scan
DM = Setting mode
SI = Start interlock
RS = Series-wiring

To get detailed information about the products and certificates, visit products.schmersal.com.

SAFETY LIGHT GRIDS AND CURTAINS

TYPE 4 – RANGE 440COM/440/445 – OVERVIEW

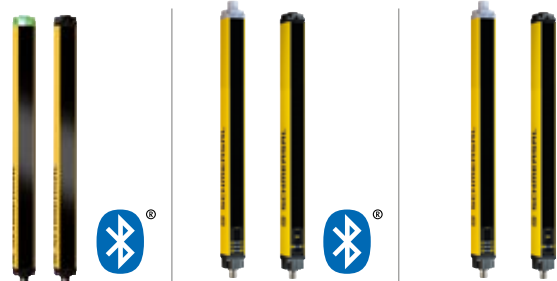

■ SLC440COM

■ SLC440

■ SLC445

Key Features

- | | | |
|--|---|---|
| <ul style="list-style-type: none"> ▪ Safety light curtain ▪ Compact ▪ Integrated Bluetooth LE interface | <ul style="list-style-type: none"> ▪ Safety light curtain ▪ Standard ▪ Integrated Bluetooth LE interface | <ul style="list-style-type: none"> ▪ Safety light curtain ▪ Multifunctional |
|--|---|---|

Other versions

AS-i SaW

–

■ ¹⁾

–

Technical features

Resolution	14, 30, 35 mm	14, 30 mm	14, 30 mm
Protection heights	330 mm ... 1930 mm	170 mm ... 1930 mm	170 mm ... 1770 mm
Number of beams	11 ... 192	8 ... 192	8 ... 144
Range of the protection field	0.3 ... 10 m, 8 ... 30 m ⁴⁾	0.3 ... 20 m	0.3 ... 10 m
Operating modes			
- Protective mode / Automatic	■	■	■
- Restart interlock (manual reset)	■	■	■
- Parameter setting	Wiring	KA-0974	KA-0976
Functions integrated			
- Contactor control	–	■	■
- Blanking of objects	–	■	■
- Muting	–	–	■
- Cyclic function	–	–	■
- Further functions (see key)	DM	BC, DQ, DM	BC, DQ, MS, DM
Electrical characteristics			
Operating voltage	24 VDC ± 10%	24 VDC ± 10%	24 VDC ± 10%
Safety output OSSD, 24 VDC	2 x PNP (timing)	2 x PNP (timing)	2 x PNP (timing)
Response time OSSD	10 ... 28 ms	10 ... 28 ms	10 ... 27 ms
Switching capacity OSSD	500 mA	500 mA	500 mA
LED status display, 7-segment display	Status display	7-segment display	7-segment display
Mechanical data			
Execution of the electrical connection	Connector plug	Connector plug	Connector plug
Connector plug (transmitter/receiver)	4-pole / 5-pole	4-pole / 8-pole	4-pole / 12-pole
Dimensions ²⁾	27.8 x 33 mm	27.8 x 33 mm	27.8 x 33 mm
Ambient conditions			
Ambient temperature	–10 °C ... +50 °C	–25 °C ... +50 °C	–25 °C ... +50 °C
Degree of protection	IP67	IP67	IP67

Safety classification

Standards	EN ISO 13849-1, EN 62061	EN ISO 13849-1, EN 62061	EN ISO 13849-1, EN 62061
PL/SIL	e/3	e/3	e/3
Control category	4	4	4
PFH	8.05 x 10 ⁻⁹ /h	5.14 x 10 ⁻⁹ /h	5.14 x 10 ⁻⁹ /h
Certificates	TÜV, UL, EAC	TÜV, UL, EAC	TÜV, UL, EAC





■ SLG440COM



■ SLG440



■ SLG445



■ 440/COM IP69

- Safety light grid
- Compact
- Integrated Bluetooth LE interface

- Safety light grid
- Standard
- Integrated Bluetooth LE interface

- Safety light grid
- Multifunctional

- Safety light curtain SLC/light grid SLG
- Compact
- Integrated Bluetooth LE interface

–

■¹⁾

–

–

300, 400 or 500 mm	300, 400 or 500 mm	300, 400 or 500 mm	14 ... 500 mm
500, 800 or 900 mm	500, 800 or 900 mm	500, 800 or 900 mm	170 mm ... 1770 mm
2, 3 or 4 beams	2, 3 or 4 beams	2, 3 or 4 beams	8 ... 192
0.3 ... 12 m, 8 ... 60 m	0.3 ... 20 m	0.3 ... 20 m	0.3 ... 20 m
■	■	■	■
■	■	■	■
Wiring	KA-0974	KA-0976	Wiring
–	■	■	■
–	■	■	■
–	–	■	–
–	–	■	–
DM	BC, DQ, DM	BC, DQ, MS, DM	BC, DQ, DM
24 VDC ± 10%	24 VDC ± 10%	24 VDC ± 10%	24 VDC ± 10%
2 x PNP (timing)	2 x PNP (timing)	2 x PNP (timing)	2 x PNP (timing)
10 ms	10 ... 15 ms	10 ... 15 ms	10 ... 28 ms
500 mA	500 mA	500 mA	500 mA
Status display	7-segment display	7-segment display	7-segment display
Connector plug	Connector plug	Connector plug	Connector plug
4-pole / 5-pole	4-pole / 8-pole	4-pole / 12-pole	4-pole / 8-pole
27.8 x 33 mm	27.8 x 33 mm	27.8 x 33 mm	∅ 50 mm
–10 °C ... +50 °C	–25 °C ... +50 °C	–25 °C ... +50 °C	–10/–25 °C ... +50 °C
IP67	IP67	IP67	IP69

EN ISO 13849-1, EN 62061	EN ISO 13849-1, EN 62061	EN ISO 13849-1, EN 62061	EN ISO 13849-1, EN 62061
e/3	e/3	e/3	e/3
4	4	4	4
8.05 x 10 ⁻⁹ /h	5.14 x 10 ⁻⁹ /h	5.14 x 10 ⁻⁹ /h	5.14 x 10 ⁻⁹ /h
TÜV, UL, EAC	TÜV, UL, EAC	TÜV, UL, EAC	TÜV, UL, EAC

¹⁾ SLC/SLG440-AS versions without BLE available with AS-i SaW interface

²⁾ The height depends on the protection field height

³⁾ Bluetooth LE is integrated from version 3.0 onwards

⁴⁾ Range 8 ... 30 m for resolution 30 mm

Key

- BC = Beam coding
- DQ = Double acknowledgement/reset
- MS = Multiple scan
- DM = Setting mode
- SI = Start interlock

To get detailed information about the products and certificates, visit products.schmersal.com.

SAFETY LIGHT GRIDS AND CURTAINS

TYPE 4 – RANGE 440COM/440/445 – PREFERRED TYPES

Type to EN 61496	Safety	Feature	Series	Special features
Type 4	Light curtain SLC	Compact	SLC440COM	Compact
				High range
				High protection class / Compact + Protective enclosure
		Included in standard version	SLC440	Included in standard version
				Integrated status display
				High range and integrated status display
				High protection class / SLC440 + Protective enclosure
		AS-i	SLC440AS	Integrated AS-i SaW
	Multifunctional	SLC445	Muting cyclic operation with multiscan	
	Light grids SLG	Compact	SLG440COM	Compact
				High range
				High protection class / Compact + Protective enclosure
		Included in standard version	SLG440	Included in standard version
				High range
Integrated status display				
High range and integrated status display				
High protection class / SLG440 + Protective enclosure				
AS-i	SLG440AS	Integrated AS-i SaW		
Multifunctional	SLG445	Muting cyclic operation with multiscan		

xxx = For different heights and other combinations, see products.schmersal.com.

--- = The material number is dependent on the protective field heights.

	Resolution	Protection heights	Range	Type	Material number
	14 mm	330 ... 1930 mm	0,3 ... 7 m	SLC440COM-ER-xxxx-14	---
	30 mm	330 ... 1930 mm	0.3 ... 10 m	SLC440COM-ER-xxxx-30	---
	35 mm	330 ... 1930 mm	0,3 ... 7 m	SLC440COM-ER-xxxx-35	---
	30 mm	330 ... 1930 mm	8 ... 30 m	SLC440COM-ER-xxxx-30-H	---
sure PH				SLC440COM-ER-xxxx-xx	---
	14 mm	170 ... 1930 mm	0,3 ... 7 m	SLC440-ER-xxxx-14	---
	30 mm	170 ... 1930 mm	0.3 ... 10 m	SLC440-ER-xxxx-30	---
	14 mm	170 ... 1930 mm	0,3 ... 7 m	SLC440-ER-xxxx-14-01	---
	30 mm	170 ... 1930 mm	0.3 ... 10 m	SLC440-ER-xxxx-30-01	---
	14 mm	170 ... 1930 mm	3 ... 10 m	SLC440-ER-xxxx-14-H1	---
	30 mm	170 ... 1930 mm	4 ... 20 m	SLC440-ER-xxxx-30-H1	---
ure PH/SH				SLC440-ER-xxxx-xx-01	---
	14 mm	170 ... 1450 mm	0,3 ... 7 m	SLC440AS-ER-xxxx-14	---
	30 mm	170 ... 1770 mm	0.3 ... 10 m	SLC440AS-ER-xxxx-30	---
	14 mm	170 ... 1450 mm	0,3 ... 7 m	SLC445-ER-xxxx-14-01	---
	30 mm	170 ... 1770 mm	0.3 ... 10 m	SLC445-ER-xxxx-30-01	---
	2 beams	500 mm	0.3 ... 12 m	SLG440COM-ER-0500-02	103004060
	3 beams	800 mm	0.3 ... 12 m	SLG440COM-ER-0800-03	103004063
	4 beams	900 mm	0.3 ... 12 m	SLG440COM-ER-0900-04	103004064
	2 beams	500 mm	8 ... 60 m	SLC440COM-ER-0500-02-H	103054126
	3 beams	800 mm	8 ... 60 m	SLC440COM-ER-0800-03-H	103054127
	4 beams	900 mm	8 ... 60 m	SLC440COM-ER-0900-04-H	103054128
sure PH				SLG440COM-ER-xxxx-xx	---
	2 beams	500 mm	0.3 ... 12 m	SLG440-ER-0500-02	101216818
	3 beams	800 mm	0.3 ... 12 m	SLG440-ER-0800-03	101216819
	4 beams	900 mm	0.3 ... 12 m	SLG440-ER-0900-04	101216820
	2 beams	500 mm	4 ... 20 m	SLG440-ER-0500-02-H	103009186
	3 beams	800 mm	4 ... 20 m	SLG440-ER-0800-03-H	103009187
	4 beams	900 mm	4 ... 20 m	SLG440-ER-0900-04-H	103009188
	2 beams	500 mm	0.3 ... 12 m	SLG440-ER-0500-02-01	101216821
	3 beams	800 mm	0.3 ... 12 m	SLG440-ER-0800-03-01	101216822
	4 beams	900 mm	0.3 ... 12 m	SLG440-ER-0900-04-01	101216823
	2 beams	500 mm	4 ... 20 m	SLG440-ER-0500-02-H1	103009189
	3 beams	800 mm	4 ... 20 m	SLG440-ER-0800-03-H1	103009190
	4 beams	900 mm	4 ... 20 m	SLG440-ER-0900-04-H1	103009191
ure PH/SH				SLG440-ER-xxxx-xx-01	---
	2 beams	500 mm	0.3 ... 12 m	SLG440AS-ER-0500-02	103007551
	3 beams	800 mm	0.3 ... 12 m	SLG440AS-ER-0800-03	103007554
	4 beams	900 mm	0.3 ... 12 m	SLG440AS-ER-0900-04	103007557
	2 beams	500 mm	0.3 ... 12 m	SLG445-ER-0500-02-01	103005424
	3 beams	800 mm	0.3 ... 12 m	SLG445-ER-0800-03-01	103005425
	4 beams	900 mm	0.3 ... 12 m	SLG445-ER-0900-04-01	103005426
	2, 3, 4 beams	500 ... 900 mm	3 ... 20 m	SLG445-ER-xxxx-xx-H1	---

EX SAFETY LIGHT GRIDS AND CURTAINS

TYPE 4 – RANGE 440 – OVERVIEW



■ EX-SLC440



■ EX-SLG440

Key Features

- Safety light curtain
- EX Zone 1 and 21
- Range 20 m

- Safety light grid
- EX Zone 1 and 21
- Range 20 m

Technical features

Resolution	14, 30 mm	300, 400 or 500 mm
Protection heights	330 mm ... 1370 mm	500, 800 or 900 mm
Number of beams	16 ... 136	2 ... 4
Range of the protection field	0.3 ... 20 m	0.3 ... 20 m
Operating modes		
- Protective mode / Automatic	■	■
- Restart interlock (manual reset)	■	■
- Parameter setting	KA-0974	KA-0974
Functions integrated		
- Contactor control	■	■
- Blanking of objects	■	■
- Muting	-	-
- Cyclic function	-	-
- Further functions (see key)	BC, DQ, DM	BC, DQ, DM
Electrical characteristics		
Operating voltage	24 VDC ± 10%	24 VDC ± 10%
Safety output OSSD, 24 VDC	2 x PNP (timing)	2 x PNP (timing)
Response time OSSD	10 ... 27 ms	10 ... 27 ms
Switching capacity OSSD	500 mA	500 mA
LED status display, 7-segment display	7 segment display	7 segment display
Mechanical data		
Execution of the electrical connection	Connector plug: 4-pole / 8-pole	Connector plug: 4-pole / 8-pole
Connector plug (transmitter/receiver)	4-pole / 5-pole	4-pole / 12-pole
Dimensions ¹⁾	top: Ø 74 mm, bottom: Ø 100 mm	top: Ø 74 mm, bottom: Ø 100 mm
Ambient conditions		
Ambient temperature	-20 °C ... +50 °C	-20 °C ... +50 °C
Degree of protection	IP66	IP66

Safety classification

Standards	EN ISO 13849-1, EN 62061	EN ISO 13849-1, EN 62061
PL/SIL	e/3	e/3
Control category	4	4
PFH	$5.14 \times 10^{-9} /h$	$5.14 \times 10^{-9} /h$
Certificates	ATEX	ATEX

Explosion protection

Standards	EN IEC 60079-0, EN IEC 60079-1, EN IEC 60079-31, EN IEC 60079-28	EN IEC 60079-0, EN IEC 60079-1, EN IEC 60079-31, EN IEC 60079-28
Explosion protection zones	1 / 21	1 / 21
Explosion protection designation	⊕ II 2G Ex db op is IIA T6 Gb ⊕ II 2D Ex op is tb IIIC T80°C Db	⊕ II 2G Ex db op is IIA T6 Gb ⊕ II 2D Ex op is tb IIIC T80°C Db



EX SAFETY LIGHT GRIDS AND CURTAINS

TYPE 4 – RANGE 440 – PREFERRED TYPES

Type to EN 61496	Type	Range	Special features	Resolution	Protection heights	Range	Type	Material number	
Type 4	Safety light curtain EX-SLC	EX-SLC440		14 mm	330 mm	0.3 ... 7 m	EX-SLC440-ER-0330-14	103047644	
			High range	14 mm	330 mm	3 ... 10 m	EX-SLC440-ER-0330-14-H	103047651	
				30 mm	330 mm	0.3 ... 10 m	EX-SLC440-ER-0330-30	103047629	
			High range	30 mm	330 mm	4 ... 20 m	EX-SLC440-ER-0330-30-H	103047637	
				14 mm	490 mm	0.3 ... 7 m	EX-SLC440-ER-0490-14	103047645	
			High range	14 mm	490 mm	3 ... 10 m	EX-SLC440-ER-0490-14-H	103047652	
				30 mm	490 mm	0.3 ... 10 m	EX-SLC440-ER-0490-30	103047631	
			High range	30 mm	490 mm	4 ... 20 m	EX-SLC440-ER-0490-30-H	103047638	
				14 mm	650 mm	0.3 ... 7 m	EX-SLC440-ER-0650-14	103047646	
			High range	14 mm	650 mm	3 ... 10 m	EX-SLC440-ER-0650-14-H	103047653	
				30 mm	650 mm	0.3 ... 10 m	EX-SLC440-ER-0650-30	103047632	
			High range	30 mm	650 mm	4 ... 20 m	EX-SLC440-ER-0650-30-H	103047639	
				14 mm	810 mm	0.3 ... 7 m	EX-SLC440-ER-0810-14	103047647	
			High range	14 mm	810 mm	3 ... 10 m	EX-SLC440-ER-0810-14-H	103047654	
				30 mm	810 mm	0.3 ... 10 m	EX-SLC440-ER-0810-30	103047633	
			High range	30 mm	810 mm	4 ... 20 m	EX-SLC440-ER-0810-30-H	103047640	
				14 mm	970 mm	0.3 ... 7 m	EX-SLC440-ER-0970-14	103047648	
			High range	14 mm	970 mm	3 ... 10 m	EX-SLC440-ER-0970-14-H	103047655	
				30 mm	970 mm	0.3 ... 10 m	EX-SLC440-ER-0970-30	103047634	
			High range	30 mm	970 mm	4 ... 20 m	EX-SLC440-ER-0970-30-H	103047641	
				14 mm	1130 mm	0.3 ... 7 m	EX-SLC440-ER-1130-14	103047649	
			High range	14 mm	1130 mm	3 ... 10 m	EX-SLC440-ER-1130-14-H	103047656	
				30 mm	1130 mm	0.3 ... 10 m	EX-SLC440-ER-1130-30	103047635	
			High range	30 mm	1130 mm	4 ... 20 m	EX-SLC440-ER-1130-30-H	103047642	
				14 mm	1370 mm	0.3 ... 7 m	EX-SLC440-ER-1370-14	103047650	
			High range	14 mm	1370 mm	3 ... 10 m	EX-SLC440-ER-1370-14-H	103047657	
				30 mm	1370 mm	0.3 ... 10 m	EX-SLC440-ER-1370-30	103047636	
			High range	30 mm	1370 mm	4 ... 20 m	EX-SLC440-ER-1370-30-H	103047643	
		Safety light grids EX-SLG	EX-SLG440		2 beams	500 mm	0,3 ... 12 m	EX-SLG440-ER-0500-02	103047621
	High range			2 beams	500 mm	4 ... 20 m	EX-SLG440-ER-0500-02-H	103047625	
				3 beams	800 mm	0,3 ... 12 m	EX-SLG440-ER-0800-03	103047622	
	High range			3 beams	800 mm	4 ... 20 m	EX-SLG440-ER-0800-03-H	103047626	
	4 beams			900 mm	0,3 ... 12 m	EX-SLG440-ER-0900-04	103047624		
High range	4 beams	900 mm	4 ... 20 m	EX-SLG440-ER-0900-04-H	103047627				

¹⁾ The height depends on the protection field height

Key

BC = Beam coding
 DQ = Double acknowledgement/reset
 MS = Multiple scan
 DM = Setting mode
 SI = Start interlock

To get detailed information about the products and certificates, visit products.schmersal.com.

SAFETY LIGHT GRIDS AND CURTAINS

SAFETY MONITORING MODULES



■ SRB-E-301MC



■ SRB-E-301ST

Key Features

- Function STOP 0
- 1- or 2-channel control
- Start button / autostart
- 3 safety contacts
- 1 auxiliary contact

- Function STOP 0
- 1- or 2-channel control
- Monitored start button / autostart
- 3 safety contacts
- 1 auxiliary contact

Technical features

Electrical characteristics		
Operating voltage	24 VAC / VDC -20 % / +20 %	24 VAC / VDC -20 % / +20 %
Operating current	0.1 A	0.1 A
Max. switching capacity of the safety contacts	3 x 230 V / 6 A	3 x 230 V / 6 A
of the safe semi-conductor outputs	-	-
of the auxiliary contacts	1 x 24 VDC / 1 A	1 x 24 VDC / 1 A
of the signalling outputs	-	-
Drop-out delay STOP 0	< 10 ms	< 10 ms
STOP 1	-	-
Mechanical data		
With removable terminals	■	■
Dimensions (H x W x D)	22.5 x 98 x 115 mm	22.5 x 98 x 115 mm
Environmental conditions		
Ambient temperature	-25 °C ... +60 °C	-25 °C ... +60 °C

Safety classification

Standards	EN ISO 13849-1, IEC 61508	EN ISO 13849-1, IEC 61508
PL/SIL	e/3	e/3
Control category	4	4
PFH	< 6 x 10 ⁻⁹ /h	< 1.25 x 10 ⁻⁸ /h
Certificates	TÜV, cULus, CCC, EAC	TÜV, cULus, CCC, EAC



To get detailed information about the products and certificates, visit products.schmersal.com.



■ SRB-E-204ST



■ SRB-E-302ST



■ SRB202MSL

- Input expander module
- Monitoring of 4 sensors
- Start button / autostart
- 2 safety outputs
- 4 signalling outputs

- Function STOP 0
- Monitoring of 2 sensors
- 1- or 2-channel control
- Start button / autostart
- 2 safety contacts, 1 safety output
- 2 signalling outputs

- Muting function
- 2 or 4 muting sensors
- Lamp current monitoring
- 2 safety contacts
- 2 signalling outputs

24 VDC -20 % / +20 % 0.125 A	24 VDC -20 % / +20 % 0.125 A	24 VDC -15% / +20% 0.24 A
-	2 x 230 V / 6 A	2 x 24 VDC / 4 A
2 x 24 V / 2 A	1 x 24 V / 2 A	-
-	-	-
4 x 24 V / 100 mA	2 x 24 V / 100 mA	24 VDC / 0.05 A
< 10 ms	< 10 ms	< 20 ms
-	-	-
■	■	■
22.5 x 98 x 115 mm	22.5 x 98 x 115 mm	45 x 100 x 121 mm
-25 °C ... +60 °C	-25 °C ... +60 °C	-25 °C ... +45 °C

EN ISO 13849-1, IEC 61508	EN ISO 13849-1, EN IEC 61508, EN IEC 62061	EN ISO 13849-1, IEC 61508
e/3	e/3	e/3
4	4	4
< 2.66 x 10 ⁻⁹ /h	< 1.25 x 10 ⁻⁹ /h; < 2.66 x 10 ⁻⁹ /h	< 2.0 x 10 ⁻⁸ /h
TÜV, cULus, CCC, EAC	TÜV, cULus, CCC, EAC	cULus, EAC

SAFETY LIGHT GRIDS AND CURTAINS







ACCESSORIES

<p>Protective enclosure SG5/SG6</p>  <ul style="list-style-type: none"> Protective enclosure for SLC/SLG Protection field heights to 970 mm: SG5 to 1930 mm: SG6 <p>103001594 103001596</p>	<p>Protective cover SGS5/SGS6</p>  <ul style="list-style-type: none"> Protective cover for SG5 and SG6 Protection field heights to 970 mm: SGS5 to 1930 mm: SGS6 <p>103001595 103001597</p>	<p>Tilted mirror for SG5/SG6</p>  <ul style="list-style-type: none"> Tilted mirror for SG5 and SG6 1000 mm: ULS-SG-1000 1870 mm: ULS-SG-1870 <p>103002489 103016046</p>
<p>Mounting post MST</p>  <ul style="list-style-type: none"> Mounting stands Base L/W 135x135 mm Height 500 – 2000 mm 	<p>Deflecting mirror ULS-M</p>  <ul style="list-style-type: none"> Deflecting mirror series M Mirror height 350 – 1870 mm Included in delivery: tilted mirror and qty. 2 mounting brackets 	<p>Aligning aid EA5</p>  <ul style="list-style-type: none"> Alignment kit, laser beam 30 m Alignment kit for all SLC/SLG series EA5 <p>101211456</p>
<p>Parametrisation cable KA-0974</p>  <ul style="list-style-type: none"> Parametrisation cable for SLC/SLG 440 Y-splitter, M12, 8-pole with P-button <p>KA-0974 101217615</p>	<p>Parametrisation cable KA-0896</p>  <ul style="list-style-type: none"> Parametrisation cable for SLC/SLG 440COM + SLC/SLG 240COM Y-splitter M12, 5-pole with command device <p>KA-0896 101030161</p>	<p>Parametrisation cable KA-0975</p>  <ul style="list-style-type: none"> Parametrisation cable for SLC/SLG 440-AS Y-splitter M12, 8-pole with command device <p>KA-0975 103005659</p>

Detailed information can be found at products.schmersal.com.

SAFETY LIGHT GRIDS AND CURTAINS









ACCESSORIES

Connector plug, 4-pole	Connector plug, 5-pole	Connector plug, 8-pole																														
 <ul style="list-style-type: none"> ■ Connector plug M12, straight, 4 pole ■ Cable length <table style="width: 100%; border: none;"> <tr> <td style="width: 50%;">5 m</td> <td style="width: 20%;">KA-0804</td> <td style="width: 30%;"></td> </tr> <tr> <td>10 m</td> <td>KA-0805</td> <td></td> </tr> <tr> <td>20 m</td> <td>KA-0808</td> <td></td> </tr> </table> 	5 m	KA-0804		10 m	KA-0805		20 m	KA-0808		 <ul style="list-style-type: none"> ■ Connector plug M12, straight, 5 pole ■ Cable length <table style="width: 100%; border: none;"> <tr> <td style="width: 50%;">5 m</td> <td style="width: 20%;">A-K5P-M12-S-G-5M-BK-2-X-A-4-69</td> <td style="width: 30%;"></td> </tr> <tr> <td>10 m</td> <td>A-K5P-M12-S-G-10M-BK-2-X-A-4-69</td> <td></td> </tr> <tr> <td>15 m</td> <td>A-K5P-M12-S-G-15M-BK-2-X-A-4-69</td> <td></td> </tr> </table> 	5 m	A-K5P-M12-S-G-5M-BK-2-X-A-4-69		10 m	A-K5P-M12-S-G-10M-BK-2-X-A-4-69		15 m	A-K5P-M12-S-G-15M-BK-2-X-A-4-69		 <ul style="list-style-type: none"> ■ Connector plug M12, straight, 8 pole ■ Cable length <table style="width: 100%; border: none;"> <tr> <td style="width: 50%;">5 m</td> <td style="width: 20%;">KA-0904</td> <td style="width: 30%;"></td> </tr> <tr> <td>10 m</td> <td>KA-0905</td> <td></td> </tr> <tr> <td>15 m</td> <td>KA-0908</td> <td></td> </tr> </table> 	5 m	KA-0904		10 m	KA-0905		15 m	KA-0908				
5 m	KA-0804																															
10 m	KA-0805																															
20 m	KA-0808																															
5 m	A-K5P-M12-S-G-5M-BK-2-X-A-4-69																															
10 m	A-K5P-M12-S-G-10M-BK-2-X-A-4-69																															
15 m	A-K5P-M12-S-G-15M-BK-2-X-A-4-69																															
5 m	KA-0904																															
10 m	KA-0905																															
15 m	KA-0908																															
Connector plug, 12-pole	Protective enclosure SH – stainless steel (440)	Protective enclosure PH – polyamide (440)																														
 <ul style="list-style-type: none"> ■ Connector plug M12, straight, 12 pole ■ Cable length <table style="width: 100%; border: none;"> <tr> <td style="width: 50%;">5 m</td> <td style="width: 20%;">KA-0980</td> <td style="width: 30%;">101213352</td> </tr> <tr> <td>10 m</td> <td>KA-0981</td> <td>101213353</td> </tr> </table> 	5 m	KA-0980	101213352	10 m	KA-0981	101213353	 <ul style="list-style-type: none"> ■ Protective enclosure IP69 <table style="width: 100%; border: none;"> <tr> <td style="width: 50%;">to 490 mm:</td> <td style="width: 20%;">SH-440-ER-01</td> <td style="width: 30%;">103026832</td> </tr> <tr> <td>to 890 mm:</td> <td>SH-440-ER-02</td> <td>103026833</td> </tr> <tr> <td>to 1290 mm:</td> <td>SH-440-ER-03</td> <td>103026834</td> </tr> <tr> <td>to 1770 mm:</td> <td>SH-440-ER-04</td> <td>103026835</td> </tr> </table> 	to 490 mm:	SH-440-ER-01	103026832	to 890 mm:	SH-440-ER-02	103026833	to 1290 mm:	SH-440-ER-03	103026834	to 1770 mm:	SH-440-ER-04	103026835	 <ul style="list-style-type: none"> ■ Protective enclosure IP69 <table style="width: 100%; border: none;"> <tr> <td style="width: 50%;">to 490 mm:</td> <td style="width: 20%;">PH-440-ER-01</td> <td style="width: 30%;">103026836</td> </tr> <tr> <td>to 890 mm:</td> <td>PH-440-ER-02</td> <td>103026837</td> </tr> <tr> <td>to 1290 mm:</td> <td>PH-440-ER-03</td> <td>103026838</td> </tr> <tr> <td>to 1770 mm:</td> <td>PH-440-ER-04</td> <td>103026839</td> </tr> </table> 	to 490 mm:	PH-440-ER-01	103026836	to 890 mm:	PH-440-ER-02	103026837	to 1290 mm:	PH-440-ER-03	103026838	to 1770 mm:	PH-440-ER-04	103026839
5 m	KA-0980	101213352																														
10 m	KA-0981	101213353																														
to 490 mm:	SH-440-ER-01	103026832																														
to 890 mm:	SH-440-ER-02	103026833																														
to 1290 mm:	SH-440-ER-03	103026834																														
to 1770 mm:	SH-440-ER-04	103026835																														
to 490 mm:	PH-440-ER-01	103026836																														
to 890 mm:	PH-440-ER-02	103026837																														
to 1290 mm:	PH-440-ER-03	103026838																														
to 1770 mm:	PH-440-ER-04	103026839																														
Protective enclosure PH – polyamide (440COM)	Protective enclosure PT with IP67 protection	Test rod PLS-01/-02																														
 <ul style="list-style-type: none"> ■ Protective enclosure IP69 <table style="width: 100%; border: none;"> <tr> <td style="width: 50%;">to 490 mm:</td> <td style="width: 20%;">PH-COM4-ER-01</td> <td style="width: 30%;">103026840</td> </tr> <tr> <td>to 890 mm:</td> <td>PH-COM4-ER-02</td> <td>103026841</td> </tr> <tr> <td>to 1290 mm:</td> <td>PH-COM4-ER-03</td> <td>103026843</td> </tr> <tr> <td>to 1770 mm:</td> <td>PH-COM4-ER-04</td> <td>103026844</td> </tr> </table> 	to 490 mm:	PH-COM4-ER-01	103026840	to 890 mm:	PH-COM4-ER-02	103026841	to 1290 mm:	PH-COM4-ER-03	103026843	to 1770 mm:	PH-COM4-ER-04	103026844	 <ul style="list-style-type: none"> ■ Protective enclosure PT with IP67 protection for SLC440 170 – 1770 mm: PT-440-ER-xxxx ■ Protective enclosure without IP69 protection for SLC440COM 330 – 1770 mm: PT-COM4-ER-xxxx 	 <ul style="list-style-type: none"> ■ Test rod <table style="width: 100%; border: none;"> <tr> <td style="width: 50%;">30 mm diameter:</td> <td style="width: 20%;">PLS-01</td> <td style="width: 30%;">101207768</td> </tr> <tr> <td>14 mm diameter:</td> <td>PLS-02</td> <td>101207769</td> </tr> </table> 	30 mm diameter:	PLS-01	101207768	14 mm diameter:	PLS-02	101207769												
to 490 mm:	PH-COM4-ER-01	103026840																														
to 890 mm:	PH-COM4-ER-02	103026841																														
to 1290 mm:	PH-COM4-ER-03	103026843																														
to 1770 mm:	PH-COM4-ER-04	103026844																														
30 mm diameter:	PLS-01	101207768																														
14 mm diameter:	PLS-02	101207769																														

Detailed information can be found at products.schmersal.com.

SAFETY LIGHT GRIDS AND CURTAINS

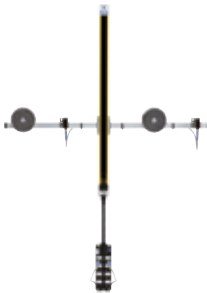
ACCESSORIES – MUTING

<p>MCU-02 103005572</p>  <ul style="list-style-type: none"> ■ Muting connection unit ■ Release/override, transmitter unit (E), up to 4 muting sensors, muting lamp 	<p>S100-PR 103040805</p>  <ul style="list-style-type: none"> ■ Muting sensor M8, 4-pole ■ Reflection light barrier ■ Range 0.1 ... 6.0 m ■ Mounting brackets not included in the delivery 	<p>KA-0976 103005575</p>  <ul style="list-style-type: none"> ■ Programming cable for SLC/SLG445 ■ P-button with connector plug M12, 12-pole
<p>MUT-SET-L-01 103006073</p>  <ul style="list-style-type: none"> ■ Muting set T-version for mounting to the assembly stand MST ■ Set complete with 2 muting sensors, MCU-02, attachment and cable ■ Set without SLC/SLG445 and MST 	<p>MUT-SET-L-02 103006074</p>  <ul style="list-style-type: none"> ■ Muting set L-version for mounting to the sensor profile ■ Set complete with 2 muting sensors, MCU-02, attachment and cable ■ Set without SLC/SLG445 and MST 	<p>MUT-SET-T-01 103006075</p>  <ul style="list-style-type: none"> ■ Muting set T-version for mounting to the assembly stand MST ■ Set complete with 4 muting sensors, MCU-02, attachment and cable ■ Set without SLC/SLG445 and MST
<p>MUT-SET-T-02 103006076</p>  <ul style="list-style-type: none"> ■ Muting set T-version for mounting to the sensor profile ■ Set complete with 4 muting sensors, MCU-02, attachment and cable ■ Set without SLC/SLG445 and MST 	<p>MUT-SET-T-03 103009195</p>  <ul style="list-style-type: none"> ■ Muting set T-version for mounting to the sensor profile ■ Set complete with 2 muting sensors, MCU-02, attachment and cable ■ Set without SLC/SLG445 and MST 	<p>MUT-SET-T-04 103012263</p>  <ul style="list-style-type: none"> ■ Muting set T-version for mounting to the assembly stand MST ■ Set complete with 2 muting sensors, MCU-02, attachment and cable ■ Set without SLC/SLG445 and MST

Detailed information can be found at products.schmersal.com.

SAFETY LIGHT GRIDS AND CURTAINS ACCESSORIES

SET-MSEN-01	103009196	SF5/6	103009789	ProLoop 2	103009788
 <ul style="list-style-type: none"> ■ Muting set with 2 muting sensors S100-PR, 2 reflectors RD-83 ■ With mounting angle kit MS-ST-505 and MS-1200 	 <ul style="list-style-type: none"> ■ Induction loop with 5 m circumference and 6 m connection cable for Pro Loop 2 	 <ul style="list-style-type: none"> ■ Evaluation unit for induction loops SF5/6 			
MS-1073	101207805	MS-1100	101216833	MS-1110	101216834
 <ul style="list-style-type: none"> ■ Mounting kit for deflecting mirror ULS-M ■ Set with 2 pieces 	 <ul style="list-style-type: none"> ■ Mounting kit for SLC/SLG440COM, SLC/SLG440 and SLC/SLG445 ■ Included in delivery: Angle with screws ■ Set with 4 pieces 	 <ul style="list-style-type: none"> ■ Mounting kit - Centre fixing for SLC/SLG440COM, SLC/SLG440 and SLC/SLG445 ■ Set with 2 pieces 			
SMA-80	101150262	BF-SMA-80-1	101150263	BF-SMA-80-2	101150264
 <ul style="list-style-type: none"> ■ Tilted mirror for SLB series ■ Height: 80 mm ■ Width: 120 mm 	 <ul style="list-style-type: none"> ■ Mounting bracket for attachment of tilted mirror SMA-80 (horizontal tilt) 	 <ul style="list-style-type: none"> ■ Mounting bracket for attachment of tilted mirror SMA-80 (vertical tilt) 			

Detailed information can be found at products.schmersal.com.



excellence in safety

tec.nicum is the Schmersal Group's business unit for solutions and services related to machine, plant and occupational safety.

Schmersal restructured its service business in 2024. The range of safety services offered by tec.nicum has been significantly expanded – particularly with regard to digitalisation and complete solutions for machine safety – and the global activities and expertise have been more closely integrated.

In April 2024, Schmersal founded tec.nicum – Solutions & Services GmbH as a new subsidiary, which also incorporated omnicon engineering GmbH, which Schmersal had already acquired in 2019. The headquarters of the new subsidiary is located in Kirkel-Limbach, Germany.

The four pillars on which tec.nicum's offering has been built to date – academy, consulting, engineering and integration – have been supplemented by two more: digitalisation and outsourcing.

digitalisation: tec.nicum is increasingly offering newly developed software solutions, such as a new tool for carrying out risk assessments, as well as new digital technologies such as cloud solutions, IIoT applications, digitalised lockout-tagout procedures and energy management tools.

outsourcing: tec.nicum offers companies the opportunity to completely outsource all tasks related to machine safety, from the planning and installation of control cabinets to the design of holistic safety solutions. tec.nicum provides the user with ready-to-connect plug & play solutions.

Thanks to its worldwide consultancy network, tec.nicum services are available around the globe. tec.nicum provides customers with competent, product- and manufacturer-neutral advice and supports them in the safety-related design of their machines and production lines.

tec.nicum
Schmersal Group

tec.nicum – Solutions & Services GmbH
Kirkel office

Friedrichstraße 65
66459 Kirkel-Limbach

Phone: +49 6841 77780-31
E-mail: info-en@tecnicum.com
Web: www.tecnicum.com

tec.nicum – Solutions & Services GmbH
Wuppertal office

Möddinghofe 30
42279 Wuppertal

Phone: +49 202 6474-932
E-mail: info-en@tecnicum.com
Web: www.tecnicum.com





academy



Education center

- Training courses
- Customer-specific trainings
- In-house seminars
- Certified courses (mce.expert and FSE)

consulting



Analysis and documentation

- Technical support
- Risk assessment
- CE conformity assessment
- Evaluation of machines and production lines
- Reports

engineering



Planning and design

- Technical project planning
- Conceptual project development
- Electrical and mechanical design
- Executive project management

integration



Practical application

- Turnkey approach
- Installation
- Retrofit

digitalisation



Software integration

- PSS (Production Safety System)
- SSM (Schmersal Smart Machine)
- AI and computational vision solutions
- Digital Lockout Tagout (dLOTO)
- EMS (Energy Monitoring System)

outsourcing



Serial solutions

- Plug & Play products
- ETO (Engineer to Order projects)
- Systems and cabinets

tec.nicum

The range of services offered by tec.nicum comprises six segments: academy (knowledge transfer), consulting (advisory services), engineering (technical planning), integration (execution and implementation), digitalisation (software solutions and new digital technologies) and outsourcing (complete solutions).

THE SCHMERSAL GROUP

PROTECTION FOR MAN AND MACHINE

In the demanding field of machine safety, the owner-managed Schmersal Group is one of the international market leaders. The company, which was founded in 1945, has a workforce of about 2,000 people and seven manufacturing sites on three continents along with its own companies and sales partners in more than 60 nations.

Customers of the Schmersal Group include “Global Players” in mechanical engineering and plant manufacturing and operators of machinery. They benefit from the company’s extensive expertise as a provider of systems and solutions for machine safety. In addition, Schmersal specialises in various areas including intralogistics, foodstuff production, the packaging industry, machine tool industry, lift switchgear, heavy industry and the automotive industry.

A major contribution to the systems and solutions offered by the Schmersal Group is made by tec.nicum with its comprehensive range of services: Certified Functional Safety Engineers advise machinery manufacturers and machinery operators in all aspects relating to machinery and occupational safety – and do so with product and manufacturer neutrality. Furthermore, they design and realise complex solutions for safety around the world in close collaboration with the clients.



SAFETY PRODUCTS

- Safety switches and sensors, solenoid interlocks
- Safety controllers and safety relay modules, safety bus systems
- Optoelectronic and tactile safety devices
- Automation technology: position switches, proximity switches

SAFETY SYSTEMS

- Complete solutions for safeguarding hazard areas
- Individual parametrisation and programming of safety controllers
- Tailor-made safety technology – be it for individual machines or a complex production line
- Industry-specific safety solutions

SAFETY SERVICES

- tec.nicum academy – Seminars and training
- tec.nicum consulting – Consultancy services
- tec.nicum engineering – Design and technical planning
- tec.nicum integration – Execution and installation
- tec.nicum digitalisation – Software solutions and new digital technologies
- tec.nicum outsourcing – Complete solutions



x.000 / L+W / 04.2023 / Teile-Nr. 101186592 / EN / Ausgabe 16



SCHMERSAL
THE DNA OF SAFETY

The details and data referred to have been carefully checked.
Subject to technical amendments and errors.

www.schmersal.com