



EN Operating instructions pages 1 bis 8
Original

Content

1 About this document

1.1 Function 1

1.2 Target group: authorised qualified personnel 1

1.3 Explanation of the symbols used 1

1.4 Appropriate use 1

1.5 General safety instructions 1

1.6 Warning about misuse 1

1.7 Exclusion of liability 2

2 Product description

2.1 Ordering code 2

2.2 Special versions 2

2.3 Purpose 2

2.4 Technical data 2

2.5 Safety classification 3

3 Mounting

3.1 General mounting instructions 3

3.2 Mounting of the sensors 3

3.3 Installation in Zone 2: particular conditions 3

3.4 Dimensions 4

4 Electrical connection

4.1 General information for electrical connection 4

5 Operating principle and settings

5.1 LED functions 4

5.2 Description of the terminals 4

5.3 Functional description 4

5.4 Adjustment 4

6 Set-up and maintenance

6.1 Functional testing 5

6.2 Maintenance 5

7 Disassembly and disposal

7.1 Disassembly 5

7.2 Disposal 5

8 Appendix

8.1 Wiring examples 5

8.2 Start configuration 5

8.3 Sensor configuration 6

8.4 Actuator configuration 7

9 Electrical apparatus

9.1 Intrinsically safe apparatus 7

9.2 Simple electrical apparatus 7

9.3 Guidelines for installation 7

10 EU Declaration of conformity

1. About this document

1.1 Function

This operating instructions manual provides all the information you need for the mounting, set-up and commissioning to ensure the safe operation and disassembly of the safety switchgear. The operating instructions must be available in a legible condition and a complete version in the vicinity of the device.

1.2 Target group: authorised qualified personnel

All operations described in this operating instructions manual must be carried out by trained specialist personnel, authorised by the plant operator only.

Please make sure that you have read and understood these operating instructions and that you know all applicable legislations regarding occupational safety and accident prevention prior to installation and putting the component into operation.

The machine builder must carefully select the harmonised standards to be complied with as well as other technical specifications for the selection, mounting and integration of the components.

1.3 Explanation of the symbols used



Information, hint, note:

This symbol indicates useful additional information.



Caution: Failure to comply with this warning notice could lead to failures or malfunctions.

Warning: Failure to comply with this warning notice could lead to physical injury and/or damage to the machine.

1.4 Appropriate use

The Schmersal range of products is not intended for private consumers.

The products described in these operating instructions are developed to execute safety-related functions as part of an entire plant or machine. It is the responsibility of the manufacturer of a machine or plant to ensure the correct functionality of the entire machine or plant.

The safety switchgear must be exclusively used in accordance with the versions listed below or for the applications authorised by the manufacturer. Detailed information regarding the range of applications can be found in the chapter "Product description".

1.5 General safety instructions

The user must observe the safety instructions in this operating instructions manual, the country specific installation standards as well as all prevailing safety regulations and accident prevention rules.



Further technical information can be found in the Schmersal catalogues or in the online catalogue on the Internet: products.schmersal.com.

The information contained in this operating instructions manual is provided without liability and is subject to technical modifications.

There are no residual risks, provided that the safety instructions as well as the instructions regarding mounting, commissioning, operation and maintenance are observed.

1.6 Warning about misuse



In case of improper use or manipulation of the safety switchgear, personal hazards or damages to machinery or plant components cannot be excluded.

1.7 Exclusion of liability

We shall accept no liability for damages and malfunctions resulting from defective mounting or failure to comply with this operating instructions manual. The manufacturer shall accept no liability for damages resulting from the use of unauthorised spare parts or accessories.

For safety reasons, invasive work on the device as well as arbitrary repairs, conversions and modifications to the device are strictly forbidden, the manufacturer shall accept no liability for damages resulting from such invasive work, arbitrary repairs, conversions and/or modifications to the device.

2. Product description

2.1 Ordering code

This operating instructions manual applies to the following types:

SRB200EXi-1A



Only if the information described in this operating instructions manual are followed correctly, the safety function and therefore the compliance with the Machinery Directive and the Explosion Protection Directive is maintained.

2.2 Special versions

For special versions, which are not listed in the order code below 2.1, these specifications apply accordingly, provided that they correspond to the standard version.

2.3 Purpose

The safety inputs of the SRB200EXi-1A safety-monitoring module have an intrinsically safe design according to EN 60079-11 (ABNT NBR IEC 60079-11). As associated, intrinsically safe equipment, the SRB can evaluate sensors located in the Zone 2 / 22, 1 / 21 and must be installed outside of the EX area in a suitable control box or control cabinet.

The SRB 200 EXi-1A safety-monitoring module can also be used in Zone 2 areas, when mounted in a suitable enclosure in accordance with EN 60079-7 (ABNT NBR IEC 60079-7), EN IEC 60079-15 (ABNT NBR IEC 60079-15) with at least IP54 degree of protection. The relay contacts for the safety enabling signal are designed with degree of protection ec, the terminals for the supply with ec and those for the signal inputs with ib.

The safety function is defined as the opening of release 13-14 when the inputs S11-S12 or S21-S22 are opened. The safety-relevant current path with output contact 13-14 meets the following requirements under observation of a B_{10D} value assessment (also refer to "Requirements of EN ISO 13849-1"):

- Category 4 – PL e to EN ISO 13849-1
- SIL 3 to IEC 61508

To determine the Performance Level (PL) to EN ISO 13849-1 of the entire safety function (e.g. sensor, logic, actuator), an assessment of all relevant components is required.



The entire concept of the control system, in which the safety component is integrated, must be validated to the relevant standards.

2.4 Technical data

SRB200EXi-1A as associated apparatus

Marking in accordance with the ATEX Directive: II 3 (2) G
 II (2) D

Marking in accordance with standards:

- ATEX, IECEx, INMETRO: Ex ec nC [ib Gb] IIC T5 Gc
[Ex ib Db] IIIC

Applied standards: EN 60204-1, EN 60947-5-1, EN ISO 13849-1, IEC 61508

- ATEX: EN IEC 60079-0, EN 60079-7, EN 60079-11, EN IEC 60079-15

- IECEx: IEC 60079-0, IEC 60079-7, IEC 60079-11, IEC 60079-15

- INMETRO: ABNT NBR IEC 60079-0, ABNT NBR IEC 60079-7, ABNT NBR IEC 60079-11, ABNT NBR IEC 60079-15

Certificate number:

- ATEX: TÜV 22 ATEX 8837 X

- IECEx: IECEx TUR 22.0047 X

- INMETRO: TÜV 23.1033 X

Safety-related data for intrinsic safety (Ex i)

Maximum safety voltage U_m : 253 VAC
(caution: U_m is not a rated voltage!)

Inputs: S11-S12, S21-S22, X1-X3:
[Ex ib Gb] IIC bzw. [Ex ib Db] IIIC

Temperature class: T5

Voltage U_o : 33.6 V

Current I_o : 57.0 mA

Capacity P_o : 478.8 mW (linear characteristic)

Separation (intrinsically safe / other circuits): safe separation according to EN 60079-11
(ABNT NBR IEC 60079-11)
Voltage peak value 375 V

Gas group	II C					II B				
	26	36	46	49	160	180	230	280	350	412
External capacity C_o (nF)										
external inductivity L_o (mH)	4.0	2.0	1.0	0.5	38.0	5.0	2.0	1.0	0.5	0.2

Reference values for cable to EN 60079-14

(cable with 2 or 3 conductors):

$C \approx 200$ nF/km, $L \approx 1$ mH/km ($C \approx 200$ pF/m, $L \approx 1$ μ H/m)

Reference values for cable with 3 to 6 conductors:

$C \approx 400$ nF/km, $L \approx 2$ mH/Km ($C \approx 400$ pF/m, $L \approx 2$ μ H/m)

General data

Climate resistance: EN 60068-2-78

Mounting: snaps onto standard rail to EN 60715

Terminal designations: EN 60947-1

Material of the housings: Plastic, glass-fibre reinforced thermoplastic, ventilated

Material of the contacts: AgSnO, self-cleaning, positive drive

Weight: approx. 265 g

Start conditions: Automatic or start button

Feedback circuit (Y/N): yes

Pull-in delay for automatic start: typ. 300 ms

Drop-out delay in case of emergency stop: typ. 20 ms

Drop-out delay on "supply failure": typ. 20 ms

Bridging in case of voltage drops: typ. 15 ms

Mechanical data

Connection type: Screw connection

Cable section: min. 0.25 mm² / max. 2.5 mm²

Connecting cable: rigid or flexible

Tightening torque for the terminals: 0.6 Nm

With removable terminals (Y/N): No

Mechanical life: 10 million operations

Electrical life: Derating curve available on request

Resistance to shock: 10 g / 11 ms

Resistance to vibration in accordance with EN 60068-2-6: 10 ... 55 Hz, Amplitude 0.35 mm

Ambient conditions

Ambient temperature:	-25 °C ... +60 °C
Storage and transport temperature:	-40 °C ... +85 °C
Degree of protection:	Enclosure: IP40 Terminals: IP20 Clearance: IP54
Air clearances and creepage distances:	EN 60664-1: 4 kV/2 (basic insulation), EN 60079-11
EMC rating:	to EMC Directive



Note external heat and/or cold source.

Electrical data

Contact resistance in new state:	max. 100 mΩ
Power consumption:	max. 3.0 W
Rated operating voltage U_e :	24 VDC -15% / +20%, residual ripple max. 10%
Frequency range:	50 / 60 Hz
Recommended fuse for the operating voltage:	internal fuse: -F1: T 50 mA / 250 V -F2: T 100 mA / 250 V

Monitored inputs

Cross-wire detection (Y/N):	Yes
Wire breakage detection (Y/N):	Yes
Earth leakage detection (Y/N):	Yes
Number of NO contacts:	0
Number of NC contacts:	2
Cable lengths:	see EX-relevant Data
Conduction resistance:	see EX-relevant Data

Outputs

Number of safety contacts:	2
Number of auxiliary contacts:	0
Number of signalling outputs:	0
Switching capacity of the safety contacts:	13-14: max. 230 V, 3 A ohmic (inductive in case of appropriate protective wiring) min. 10 V / 10 mA
Switching capacity of the auxiliary contacts:	24 VDC / 2 A
Fuse rating of the safety contacts:	external ($I_R = 1000$ A) to EN 60947-5-1 Safety fuse 4 A quick blow, 3.15 A slow blow
Fuse rating for the auxiliary contacts:	external ($I_R = 1000$ A) to EN 60947-5-1 Safety fuse 2.5 A quick blow, 2 A slow blow
Utilisation category to EN 60947-5-1:	AC-15: 230 V / 3 A DC-13: 24 V / 3 A

The data specified in this manual is applicable when the component is operated with rated operating voltage $U_e \pm 0\%$.

2.5 Safety classification

Standards:	EN ISO 13849-1, IEC 61508
PL:	up to e
Category:	up to 4
DC:	99% (high)
CCF:	> 65 points
PFH value:	$\leq 2.00 \times 10^{-8}/h$
SIL:	up to 3
Mission time:	20 years

The PFH values of $2.00 \times 10^{-8}/h$ apply to the combinations of contact load (current through enabling contacts) and number of switching cycles (n_{oply}) mentioned in the table below. At 365 operating days per year and a 24-hours operation, this results in the below-mentioned switching cycle times (t_{cycle}) for the relay contacts. Diverging applications upon request.

Contact load	n_{oply}	t_{cycle}
20 %	525,600	1.0 min
40 %	210,240	2.5 min
60 %	75,087	7.0 min
80 %	30,918	17.0 min
100 %	12,223	43.0 min

3. Mounting

3.1 General mounting instructions

Mounting: snaps onto standard rails to EN 60715.

Snap the bottom of the enclosure slightly tilted forwards in the rail and push up until it latches in position.

3.2 Mounting of the sensors

The installation of the intrinsically safe current circuits must be executed in accordance with the applicable standards EN 60079-14 (ABNT NBR IEC 60079-14).



According to EN 60079-11 (ABNT NBR IEC 60079-11), the following must be observed for the installation: a distance of ≥ 6 mm must be observed between the terminals of the intrinsically safe current circuits and other intrinsically safe current circuits. Between the terminals of the intrinsically safe current circuits and other, non-intrinsically safe current circuits, a distance of ≥ 50 mm must be observed. The commissioning and installation are to be executed by qualified professionals only.

3.3 Installation in Zone 2: particular conditions

The devices must be installed in control or junction boxes, which meet the requirements of EN 60079-7 (ABNT NBR IEC 60079-7), EN IEC 60079-15 (ABNT NBR IEC 60079-15) and have at least degree of protection IP54 (see Fig. 1). To respect temperature class T5, the device must have a free volume of at least 2,400 cm³. Please make sure that you have read and understood these operating instructions and that you know all applicable legislations regarding occupational safety and accident prevention prior to installation and putting the component into operation. The intrinsically safe current circuits of the device (light blue terminals) may be lead in explosion-endangered areas. In this case, it must be especially observed that they are safely separated from all non-intrinsically safe current circuits.



The connection and separation of the connections of non-intrinsically safe current circuits is not authorised in explosion-endangered atmospheres. Only use a damp cloth to clean the enclosure. The lifetime of the safety-monitoring related to the ignition protection class "nC" is at least 15 years. **Upon expiration of this time, the safety-monitoring module must be replaced either returned to the manufacturer for check-up!**



The temperature specifications (-25 °C $\leq T_a \leq +60$ °C) of the safety-monitoring module are related to a volume of the control cabinet of at least approx. 2,400 cm³ for each SRB. The distance with regard to other safety-monitoring module imperatively must be at least approx. 5 cm.

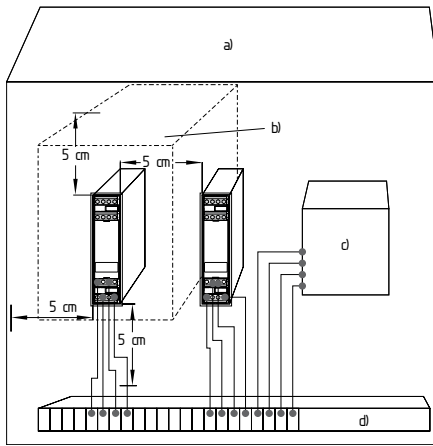

Fig. 1
a) IP54 control box suitable for installation in Zone 2 in accordance with EN IEC 60079-7 (ABNT NBR IEC 60079-7), EN IEC 60079-15 (ABNT NBR IEC 60079-15)
b) Air around the safety-monitoring module approx. 2,400 cm³ (8.25 × 16 × 18.1 cm)
c) Protection (suitable for Zone 2)
d) Clips (suitable for Zone 2)

Potential equalisation: wiring of the PA terminals (Fig. 2)

The grounding of intrinsically safe circuits must be carried out in accordance with the requirements EN 60079-14 (ABNT NBR IEC 60079-14).



Fig. 2

3.4 Dimensions

All measurements in mm.

Device dimensions (H/W/D): 100 x 22.5 x 121 mm

4. Electrical connection

4.1 General information for electrical connection



The electrical connection may only be carried out by authorised personnel in a de-energised condition.



As far as the electrical safety is concerned, the protection against unintentional contact of the connected and therefore electrically interconnected apparatus and the insulation of the feed cables must be designed for the highest voltage, which can occur in the device.

Settle length x of the conductor:

- on screw terminals: 8 mm



The pre-wired cables must have strain relief and may not be put under mechanical strain.



To avoid EMC disturbances, the physical ambient and operational conditions at the place where the product is installed, must meet the provisions laid down in the paragraph "Electromagnetic Compatibility (EMC)" of EN 60204-1.

Wiring examples: see appendix

5. Operating principle and settings

5.1 LED functions

- K1: Status channel 1
- K2: Status channel 2
- U_B: Status operating voltage (LED is on, when the operating voltage on the terminals A1-A2 is ON)
- U_i: Status internal operating voltage (LED is on, when the operating voltage on the terminals A1-A2 is ON and the fuse has not been triggered).
- U_{EXI}: Status internal operating voltage (LED is on, when the operating voltage on the terminals A1-A2 is ON and the fuse F1 has not been triggered)

5.2 Description of the terminals

Voltages:	A1	+24 VDC
	A2	0 VDC
Inputs:	S11-S12	Input channel 1 (+)
	S21-S22	Input channel 2 (+)
	S21-S22	Input channel 2 (-) (with cross-wire short detection)
Outputs:	13-14/ 23-24	Safety release
	Start:	X1-X3



Signalling outputs must not be used in safety circuits.

5.3 Functional description

- The SRB200EXi-1A is a dual-channel safety-monitoring module for monitoring emergency stop command devices, guard door monitors and magnetic safety switches.
- When the safety circuits S11-S12 and S21-S22 are closed and the feedback circuit X1-X3 is closed, the safety-monitoring module is started and the enabling circuits 13-14 and 23-24 are closed.
- The enabling circuit 13-14 and 23-24 is immediately opened when the emergency stop command device or another safety equipment is operated.
- The safety-monitoring module can only be restarted, when both channels K1 and K2 have been enabled.

5.4 Adjustment

Opening the front cover (see Fig. 3)

- To open the front cover, insert a slotted screwdriver in the top and bottom cover notch and gently lift it.
- When the front cover is open, the electrostatic discharge requirements must be respected and observed.
- After setting, the front cover must be fitted back in position.

Setting the switch (see Fig. 4)

- The cross-wire short monitoring function (factory setting) is programmed by means of the switch underneath the front cover of the safety-monitoring module.
- The switch must only be operated in de-energised condition by means of a finger or an insulated blunt tool.
- Pos. nQS (top): Not cross-wire short proof, suitable for 1-channel applications with outputs connected to potential in the control circuits.
- Pos. QS (bottom), Cross-wire short proof: suitable for 2-channel applications without outputs connected to potential in the control circuit s.



Only touch the components after electrical discharge!

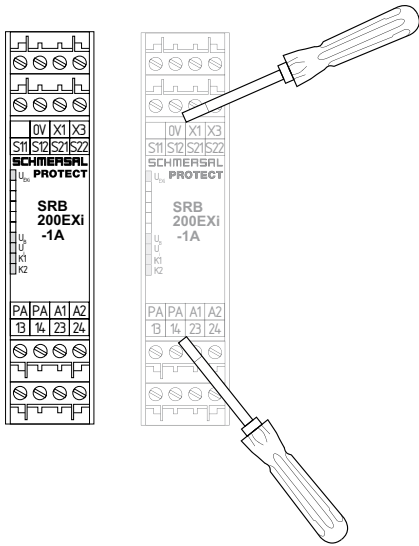

Fig. 3

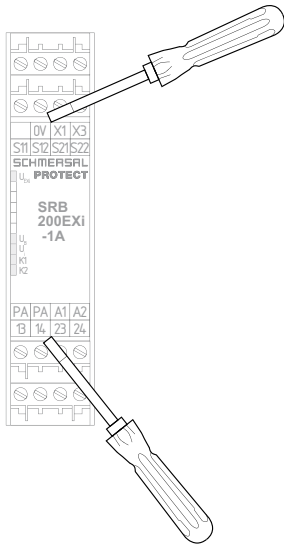

Fig. 4

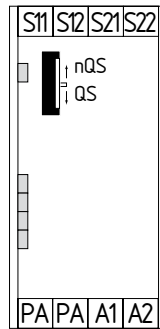

Fig. 5

6. Set-up and maintenance

6.1 Functional testing

The safety function of the safety relay module must be tested. The following conditions must be previously checked and met:

1. Correct fixing
2. Check the integrity of the cable entry and connections
3. Check the safety-monitoring module's enclosure for damage.
4. Check the electrical function of the connected sensors and their influence on the safety-monitoring module and the downstream actuators

6.2 Maintenance

A regular visual inspection and functional test, including the following steps, is recommended:

1. Check the correct fixing of the safety-monitoring module
2. Check the cable for damages
3. Check electrical function



The device has to be integrated into the periodic check-ups according to the Ordinance on Industrial Safety and Health/the ATEX Directive (1999/92/CE), however at least 1x/year.

Troubleshooting

No changes are allowed to devices, which are used in conjunction with explosion-endangered areas.

Repairs to the devices are not authorised either.

Damaged or defective components must be replaced.

7. Disassembly and disposal

7.1 Disassembly

The safety-monitoring module must be disassembled in a de-energised condition only.

Push up the bottom of the enclosure and hang out slightly tilted forwards.

7.2 Disposal

The safety relay module must be disposed of in an appropriate manner in accordance with the national prescriptions and legislations.

8. Appendix

8.1 Wiring examples

Dual-channel control, shown for a guard door monitor with two position switches where one has a positive break contact; with external reset button (R) (Fig. 6)

- Relay outputs: Suitable for 2-channel control, for increase in capacity or number of contacts by means of contactors or relays with positive-guided contacts.
- The control system recognises wire-breakage, earth faults and cross-wire shorts in the monitoring circuit.
- (R) = Feedback circuit

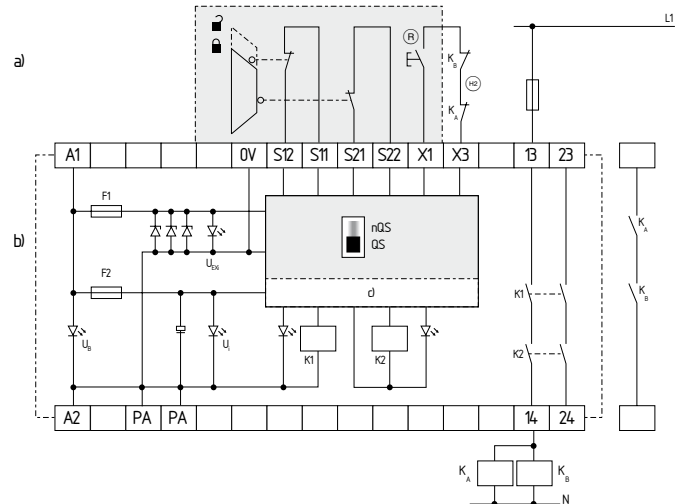

Fig. 6

a) Installation in zone 1/21

b) Installation in zone 2

c) Logic

d) Control

8.2 Start configuration

External reset button (without edge detection) (see Fig. 7)

- The reset button is integrated in the feedback circuit in series as shown.
- The safety-monitoring module is activated upon actuation of the reset button.
- The reset button is controlled through an individual intrinsically safe current circuit.
- To start the safety-monitoring module, the reset button may be designed as "simple electrical apparatus".
- Examples see chapter 9 Simple "electrical apparatus – intrinsic safety"

Automatic start (see Fig. 8)

- The automatic start is programmed by connecting the feedback circuit to the terminals. If the feedback circuit is not required, establish a bridge.
- The feedback circuit is controlled through an individual intrinsically safe current circuit.
- **Caution:** Not admitted without additional measure due to the risk of gaining access by stepping behind!
- **Caution:** within the meaning of EN 60204-1, paragraph 9.2.3.4.2, the operating mode "automatic start" is only restrictedly admissible. In particular, any inadvertent restart of the machine must be prevented by other suitable measures.



Due to the operating principle of the electronic fuse, the customer must check that no hazard is caused by an unexpected restart in circuits without reset button (automatic reset).

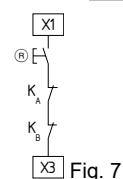

Fig. 7

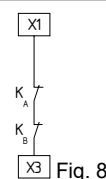

Fig. 8

8.3 Sensor configuration

Single-channel emergency stop circuit with command devices to EN ISO 13850 and EN 60947-5-5 (Fig. 9)

- Wire breakage and earth leakage in the control circuits are detected.
- For the safety circuits monitoring, the emergency stop command devices may be designed as "simple electrical apparatus".
- Examples see chapter 9 Simple "electrical apparatus – intrinsic safety"
- Category 1 – PL c to EN ISO 13849-1 possible.

Dual-channel emergency stop circuit with command devices to EN ISO 13850 and EN 60947-5-5 (Fig. 10)

- Wire breakage and earth leakage in the control circuits are detected.
- Cross-wire shorts between the control circuits are not detected.
- For the safety circuits monitoring, the emergency stop command devices may be designed as "simple electrical apparatus".
- Examples see chapter 9 Simple "electrical apparatus – intrinsic safety"
- Category 4 – PL e to EN ISO 13849-1 possible (with protective wiring).

Dual-channel emergency stop circuit with command devices to EN ISO 13850 and EN 60947-5-5 (Fig. 11)

- Wire breakage and earth leakage in the control circuits are detected.
- Cross-wire shorts between the control circuits are detected.
- For the safety circuits monitoring, the emergency stop command devices may be designed as "simple electrical apparatus".
- Examples see chapter 9 Simple "electrical apparatus – intrinsic safety"
- Category 4 – PL e to EN ISO 13849-1 possible.

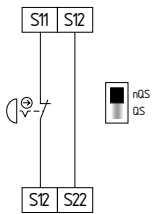

Fig. 9

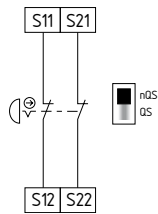

Fig. 10

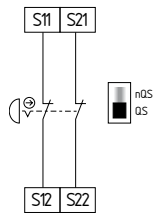

Fig. 11

Single-channel guard door monitoring circuit with interlocking devices to EN ISO 14119 (Fig. 12)

- At least one contact with positive break required.
- Wire breakage and earth leakage in the control circuits are detected.
- For the safety circuits monitoring, the interlocking devices may be designed as "simple electrical apparatus".
- Examples see chapter 9 Simple "electrical apparatus – intrinsic safety"
- Category 1 – PL c to EN ISO 13849-1 possible.

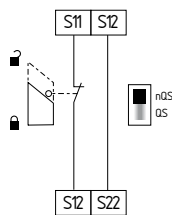

Fig. 12

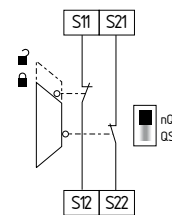

Fig. 13

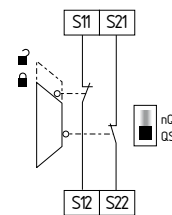

Fig. 14

Dual-channel control of magnetic safety switches to EN 60947-5-3 (see Fig. 15)

- Wire breakage and earth leakage in the control circuits are detected.
- Cross-wire shorts between the control circuits are not detected.
- For the safety circuits monitoring, the magnetic safety sensors may be designed as "simple electrical apparatus".
- Examples see chapter 9 Simple "electrical apparatus – intrinsic safety"
- Category 3 – PL e to EN ISO 13849-1 possible.

Dual-channel control of magnetic safety switches to EN 60947-5-3 (see Fig. 16)

- Wire breakage and earth leakage in the control circuits are detected.
- Cross-wire shorts between the control circuits are detected.
- For the safety circuits monitoring, the magnetic safety sensors may be designed as "simple electrical apparatus".
- Examples see chapter 9 Simple "electrical apparatus – intrinsic safety"
- Category 4 – PL e to EN ISO 13849-1 possible.



The connection of magnetic safety switches to the SRB200EXi-1A safety-monitoring module is only admitted when the requirements of the standard EN 60947-5-3 are observed.

As the technical data are regarded, the following minimum requirements must be met:

- switching capacity: min. 500 mW
- switching voltage: min. 33.6 VDC
- switching current: min. 57 mA

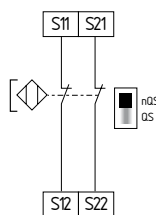

Fig. 15

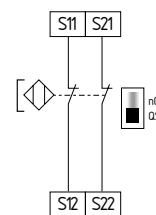

Fig. 16

8.4 Actuator configuration

Single-channel control with feedback circuit (Fig. 17)

- Suitable for increase in capacity or number of contacts by means of contactors or relays with positive-guided contacts.
- If the feedback circuit is not required, establish a bridge.

Dual-channel control with feedback circuit (Fig. 18)

- Suitable for increase in capacity or number of contacts by means of contactors or relays with positive-guided contacts.
- If the feedback circuit is not required, establish a bridge.

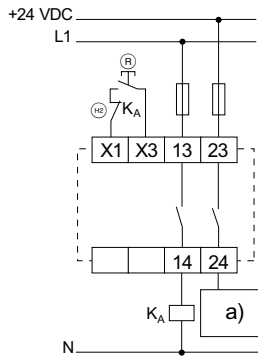

Fig. 17
a) Control
Ⓡ = Reset button
Ⓢ = Feedback circuit

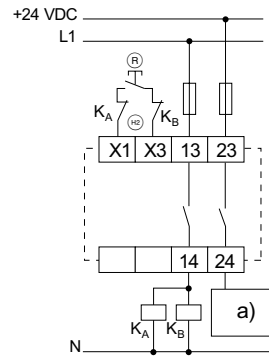

Fig. 18
a) Control
Ⓡ = Reset button
Ⓢ = Feedback circuit

9. Electrical apparatus

Intrinsically safe apparatus can be installed directly in Zone 1, 21, 2 or 22 and have a corresponding certificate from a designated body, e.g. TÜV, or are simple electrical apparatus.

Please compare the Ex data of the SRB200EXi-1R on page 3 with the desired intrinsically safe apparatus for evidence of intrinsic safety.



Only the intrinsically safe current circuit of the SRB200EXi-1A must be wired to the electrical apparatus.

Requirements for the intrinsically safe current circuit:

The enclosures have at least degree of protection IP 54 (EN 60529) for gas, IP6X for dust (IP5X in case of non-conductive dusts in Zone 22).



According to EN 60079-11 (ABNT NBR IEC 60079-11), the following must be observed for the installation: a distance of ≥ 6 mm must be observed between the terminals of the intrinsically safe current circuits and other intrinsically safe current circuits. Between the terminals of the intrinsically safe current circuits and other, non-intrinsically safe current circuits, a distance of ≥ 50 mm must be observed.

9.1 Intrinsically safe apparatus

Intrinsically safe apparatus is designated as such. Example designation in accordance with IECEx: Ex ib IIC T6 Gb

Devices that can be used as intrinsically safe apparatus:

- Command and signalling devices from the Schmersal product portfolio
- EX-T.454
- EX-BS655
- EX-RS655
- EX-ZQ 900

9.2 Simple electrical apparatus

An assessment of simple electrical apparatus must be executed according to EN 60079-11 (ABNT NBR IEC 60079-11).

As simple electrical apparatus within the meaning of intrinsic safety do not represent a potential source of ignition, the Directive 2014/34/EU is not applicable. To demonstrate the intrinsic safety according to EN 60079-14 (ABNT NBR IEC 60079-14), a declaration of the manufacturer therefore can be used.

The devices classified as simple electrical apparatus can be used in the Zones 1 / 2 and 21 / 22.

Simple electrical apparatus do not require Ex designation.

On the basis of a valid declaration of the manufacturer with an assessment as simple electrical apparatus, amongst others, the following devices from K.A. Schmersal GmbH & Co. KG can be used:

reset button

EX-RDT...
EX-RDM...

Emergency stop control units

EX-RDRZ...

Interlocking equipment

(EX-)AZ 16-...
(EX-)AZ 415-...
(EX-)AZ 3350-...
(EX-)Z/T 235-...
(EX-)Z/T 335-...

Safety sensors

(EX-)BN 20-...
(EX-)BNS 33-...*
(EX-)BNS 120-...
(EX-)BNS 180-...
(EX-)BNS 250-...*
(EX-)BNS 303-...*
* however version without LED

9.3 Guidelines for installation

EN 60079-14 (ABNT NBR IEC 60079-14):

Use in explosive-endangered areas of Zones 1 / 2 and explosive-endangered areas due to the presence of dust Zones 21 / 22. (Category 2GD and 3GD according to ATEX directives)

For reset buttons, emergency stop command devices, interlocking devices and magnetic safety switches, the following is applicable:

Instructions for the installation:

- The risk of mechanical damage to the simple electrical apparatus must be observed depending on the place of installation. Additional measures to provide for a mechanical protection are useful, for instance when a potential difference through the earth wire can occur due to damage.

Technical data in the intrinsically safe current circuit:

- Voltage U_o : 33.6 V
- Current I_o : 57 mA
- Capacity P_o : 479 mW (linear characteristic)
- C_o capacity: refer to the table with Ex-relevant data
- L_o inductivity: refer to the table with Ex-relevant data

Cable/wire (example):

- A mechanical protection for the cable(s) must be provided.
- The cable(s) must be separated from other, non-intrinsically safe current circuits.

10. EU Declaration of conformity

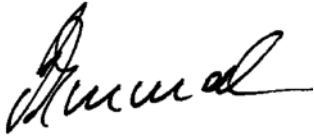
EU Declaration of conformity		
Original	K.A. Schmersal GmbH & Co. KG Möddinghofe 30 42279 Wuppertal Germany Internet: www.schmersal.com	
We hereby certify that the hereafter described components both in their basic design and construction conform to the applicable European Directives.		
Name of the component:	SRB200EXi-1A	
Type:	see ordering code	
Marking:	⊗ II 3 (2) G Ex ec nC [ib Gb] IIC T5 Gc ⊗ II (2) D [Ex ib Db] IIIC	
Description of the component:	Safety-monitoring module for emergency stop circuits and guard door monitoring	
Relevant Directives:	Machinery Directive 2006/42/EC EMC-Directive 2014/30/EU Explosion Protection Directive (ATEX) 2014/34/EU RoHS-Directive 2011/65/EU	
Applied standards:	EN IEC 60079-0:2018 EN 60079-7:2015 EN IEC 60079-7:2015 / A1:2018 EN 60079-11:2012 EN IEC 60079-15:2019 EN 60947-5-1:2017 + AC:2020 EN ISO 13849-1:2015 EN ISO 13849-2:2012	
Notified body for certification of the QA system in accordance with Appendix X in accordance with 2006/42/EC, Appendix IV in accordance with 2014/34/EU and for ATEX certification:	TÜV Rheinland Industrie Service GmbH Am Grauen Stein, 51105 Köln ID n°: 0035	
Type Examination Certificate:	TÜV 22 ATEX 8837 X	
This certificate refers only to the certification of the products in accordance with the Explosion Protection Directive 2014/34/EU (ATEX). Product conformity in accordance with the Machinery Directive 2006/42/EC is declared by the manufacturer under its own responsibility.		
Person authorised for the compilation of the technical documentation:	Oliver Wacker Möddinghofe 30 42279 Wuppertal	
Place and date of issue:	Wuppertal, October 30, 2024	
SRB200EXi-1A-I-EN		
	Authorised signature Philip Schmersal Managing Director	



The currently valid declaration of conformity can be downloaded from the internet at products.schmersal.com.

