



EN Operating instructions.pages 1 to 8
Translation of the original operating instructions

Content

1 About this document

1.1 Function 1

1.2 Target group: authorised qualified personnel. 1

1.3 Explanation of the symbols used 1

1.4 Appropriate use 1

1.5 General safety instructions 1

1.6 Warning about misuse 2

1.7 Exclusion of liability 2

2 Product description

2.1 Ordering code 2

2.2 Special versions. 2

2.3 Destination and use 2

2.4 Technical data 2

2.5 Safety classification 2

2.6 Basic principles for safe utilisation. 2

2.7 Functions 3

2.8 Operating modes 3

3 Mounting

3.1 General mounting instructions 3

3.2 Safety distance 4

3.3 Deflection. 4

4 Electrical connection

4.1 Wiring example 4

4.2 Connection example 5

5 Set-up and maintenance

5.1 Functional testing. 6

5.2 Diagnostics / Fault rectification 6

5.3 Maintenance 6

6 Disassembly and disposal

6.1 Disassembly. 6

6.2 Disposal 6

7 Declaration of conformity

7.1 EC Declaration of conformity 7

1. About this document

1.1 Function

This operating instructions manual provides all the information you need for the mounting, set-up and commissioning to ensure the safe operation and disassembly of the safety switchgear. The operating instructions must be available in a legible condition and a complete version in the vicinity of the device.

1.2 Target group: authorised qualified personnel

All operations described in this operating instructions manual must be carried out by trained specialist personnel, authorised by the plant operator only.

Please make sure that you have read and understood these operating instructions and that you know all applicable legislations regarding occupational safety and accident prevention prior to installation and putting the component into operation.

The machine builder must carefully select the harmonised standards to be complied with as well as other technical specifications for the selection, mounting and integration of the components.

1.3 Explanation of the symbols used

 **Information, hint, note:**
This symbol is used for identifying useful additional information.

 **Caution:** Failure to comply with this warning notice could lead to failures or malfunctions.
Warning: Failure to comply with this warning notice could lead to physical injury and/or damage to the machine.

1.4 Appropriate use

The products described in these operating instructions are developed to execute safety-related functions as part of an entire plant or machine. It is the responsibility of the manufacturer of a machine or plant to ensure the correct functionality of the entire machinery or plant.

The safety switchgear must be exclusively used in accordance with the versions listed below or for the applications authorised by the manufacturer. Detailed information regarding the range of applications can be found in the chapter "Product description".

1.5 General safety instructions

The user must observe the safety instructions in this operating instructions manual, the country-specific installation standards as well as all prevailing safety regulations and accident prevention rules.

 Further technical information can be found in the Schmersal catalogues or in the online catalogue on the Internet: www.schmersal.net.

The information contained in this operating instructions manual is provided without liability and is subject to technical modifications.

There are no residual risks, provided that the safety instructions as well as the instructions regarding mounting, commissioning, operation and maintenance are observed.

1.6 Warning about misuse



In case of improper use or manipulation of the safety switch-gear, personal hazards or damages to machinery or plant components cannot be excluded when safety switchgear is used. The relevant requirements of the standards ISO 13855 and ISO 13857 must be observed.

1.7 Exclusion of liability

We shall accept no liability for damages and malfunctions resulting from defective mounting or failure to comply with this operating instructions manual. The manufacturer shall accept no liability for damages resulting from the use of unauthorised spare parts or accessories.

For safety reasons, invasive work on the device as well as arbitrary repairs, conversions and modifications to the device are strictly forbidden; the manufacturer shall accept no liability for damages resulting from such invasive work, arbitrary repairs, conversions and/or modifications to the device.

2. Product description

2.1 Ordering code

SLB 200-C04-1R

2.2 Special versions

For special versions, which are not listed in the order code below 2.1, these specifications apply accordingly, provided that they correspond to the standard version.

2.3 Destination and use

In combination with one or two light barriers of the SLB 200-E/R-31-21 type, the SLB 200-C04-1R safety-monitoring module is used for the protection of accesses and the direct protection of small hazardous points on a machine. The protection of persons and devices is not guaranteed when the component is not used in accordance with the specified use.



The user must evaluate and design the safety chain in accordance with the relevant standards and the required safety level.



The entire concept of the control system, in which the safety component is integrated, must be validated to the relevant standards.

2.4 Technical data

Standards:	IEC 61496-1, CLC/TS 61496-2, ISO 13849-1
Start conditions:	Start-reset button, on/off coding
Feedback circuit:	yes
Enclosure:	polycarbonate
Mounting:	snaps onto standard DIN rail to EN 50022
Connection:	screw terminals
Cable section:	max. 2.5 mm ² (incl. conductor ferrules)
Protection class:	IP20
Rated operating voltage U _e :	24 VDC ± 15%
Rated operating current I _e :	180 mA (without load)
Inputs:	S1, S2
Monitored inputs:	max. 2 pairs of light barriers
Max. cable length:	50 m of 0.75 mm ² conductor
Enabling contacts:	1 enabling path
Utilisation category:	AC-15, DC-13
Rated operating current/voltage I _e /U _e :	2 A / 250 VAC, 2 A / 24 VDC
Contact load capacity:	max. 250 VAC
Switching voltage:	max. 250 VAC
Max. fuse rating:	2 A gG D-fuse
Signalling output:	Transistor output Y1 max. 500 mA
Switch-on time:	–
Response time:	≤ 30 ms
Function display:	3 LEDs
EMC rating:	to IEC 61496-1 (higher requirements)
Max. switching frequency:	10 Hz
Resistance to vibrations:	10 ... 55 Hz / amplitude 0.35 mm, ± 15 %
Resistance to shock:	10 g / 16 ms
Ambient temperature:	0 °C ... +50 °C
Storage and transport temperature:	–20 °C ... +80 °C
Dimensions:	45 x 84 x 118 mm

2.5 Safety classification

(only in combination with the SLB 200-E/R-31-21 safety light barriers)

Standards:	ISO 13849-1, IEC 61508, IEC 62061
PL:	d
Control Category:	2
PFH value:	
- DC 2 A:	1.01 x 10 ⁻⁷ /h, up to max. 500,000 switching cycles/ year
- AC 2 A:	2.8 x 10 ⁻⁷ /h, up to max. 50,000 switching cycles/ year
SIL:	suitable for SIL 2 applications
Service life:	20 years

2.6 Basic principles for safe utilisation

Electrically influencing the machine or plant control system must be enabled.

- A switching command from the SLB 200-C must cause the shutdown of the machinery or plant.
- The machine must not restart as long as a person is inside the hazardous area.
- Settings and changes to the safety guard must only be carried out by authorised expert staff.
- Actuation of the command devices from outside the hazardous area must be impossible.
- For the use and assembly of the light barriers, the minimum distance to the danger point, the height of the individual beams above the reference floor, the distance to reflecting surfaces and mutual interference must be observed.

2.7 Functions

In combination with the SLB 200-E/R light barriers, the SLB 04-C1-200R safety-monitoring module is a non-contact safety guard with Performance Level d (BWS-T). The safety function of the entire system is automatically checked, after each switch-on of the ESD and each manual test request (external test signal by actuation of the corresponding command device). In addition to that, a cyclic test is performed during operation.

The operation is possible:

- with one or two light barriers
- with or without start/restart interlock and
- with or without contactor control

The operating modes with start/restart interlock, contactor control and operation with two light barriers are factory set.

The desired operating modes must be set by switching the corresponding DIP switch in de-energised condition; this operation is to be carried out by authorised staff only.

If an operation with just one light barrier is desired, the light barrier pair one must be connected. The connection of the light barrier pair two is not used.

The command device (test) must be designed as normally-closed. If no NC is detected when the operating voltage is switched on (command device not connected), the safety output/enabling path remains open.

2.7.1 Operating principle after switch-on

After the operating voltage has been switched on, the safety-monitoring module performs an internal self-test. After that, the connected light barriers are activated and tested.

If no fault is detected, the further operation depends on the chosen operating mode.

2.8 Operating modes

Operation without start/restart interlock

In this operating mode, the safety output/enabling path is always closed, when no light beam of the connected light barriers is interrupted. The "relay" LED is green.

Operation with start/restart interlock

In this operating mode, the state of the command device (start button) is checked before the safety output/enabling path is closed, after the operating voltage is switched-on or after interruption of a light beam during operation. The enabling request of the restart interlock is signalled by the LED ("RESTART"). Only after the command device (start button) has been actuated and released again (actuating time at least 50 ms), the indication is turned off and the safety output/enabling path is closed.



If the system is used for access protection, the operating mode "with start/restart interlock" must be set (DIP switch 2 in position 1).

Operation with contactor control

The series-wired NC contacts of the contactors controlled by the safety output/enabling path are connected to the inputs X18 and X19.

The feedback NC contacts are checked after the operating voltage is switched on, in case of interruptions of a light beam or after a manual test request.

If the enabling paths of the contactors are not opened (e.g. contact welding), the safety output/enabling path of the SLB 200-C04-1R is not closed.

2.8.1 Setting the operating modes



To set the desired operating mode and the number of connected light barriers, remove the transparent enclosure cover of the safety-monitoring module. By doing so, three DIP switches are accessible, by means of which the operating modes and the number of connected light barriers can be selected in accordance with the table below.

Switch	Position	Function	Note
Switch 1	On	With contactor control	Factory setting
	Off	Without contactor control	-
Switch 2	On	With start/restart interlock	Factory setting
	Off	Without start/restart interlock	-
Switch 3	2	Connection of two light barriers	Factory setting
	1	Connection of one light barrier	-

2.8.2 LED display

LED	Colour	Status
„RELAY“	green LED on	Safety output / enabling path closed
	red LED on	Safety output / enabling path open
„RESTART“	yellow LED on	Waiting on authorised operation, RESTART button not yet pressed
„ERROR“	orange LED on	Internal or external fault (e.g. defective contactor or test button [N.C.] not connected)

3. Mounting

3.1 General mounting instructions

Mounting of the safety-monitoring module

Mount the SLB 200 C04-1R safety-monitoring module on the DIN rail in the control cabinet, at least IP54, and wire it in accordance with the wiring diagram and the requirements (refer to paragraph "Electrical wiring").

Mounting of the safety light barriers

The mounting possibilities are shown on the dimensional drawing and in the technical data of the corresponding safety light barrier.

When fitting the safety light barriers, the provisions of this operating instructions manual and the applicable standards and prescriptions must be observed.



Additional measures could be required to ensure that the electro-sensitive device does not present a dangerous breakdown, when other forms of light beams are available in a special application (e.g. use of wireless control devices on cranes, radiation of welding sparks or effects of stroboscopic lights).

3.2 Safety distance

Safety distance (S)

The light barriers must be mounted so that a person cannot reach the danger point or the hazardous area before the hazardous movement has come to standstill and furthermore that tampering is prevented. The safety distance "S" must be calculated to the formula of ISO 13855.

$$S = K \times T + C$$

(K = 1600 mm/s, T = total response time, C = constant)

Number of safety light barriers and height of the light beams

The number of light beams and the height of the light beams above the reference floor are defined by the requirements of the power-driven work equipment, the ISO 13855 or a risk analysis. The following table shows the applicable values to ISO 13855 at the time of printing for the height of the light beams above the reference floor and the calculation of the safety distance "S":

Number of light barriers	Height of the light beams above reference floor in mm	Calculation of the safety distance "S"
2	400 / 900	$S = (1600 \text{ mm/s} \times T) + 850 \text{ mm}$
1	750	$S = (1600 \text{ mm/s} \times T) + 1200 \text{ mm}$

T = (response time of the machine + response time SLB 200-C04-1R) in seconds

3.3 Deflection

Surfaces, which are arranged parallel to the light beam, can cause a deflection. In that case, a obstacle in the light beam will no longer be detected.

Therefore, a lateral minimum distance for the optical axis must be respected and observed with regard to reflecting surfaces or obstacles. (Fig. 1a and Fig. 1b). This distance depends on the angle of radiation of the light barrier and the distance of transmitter and receiver.

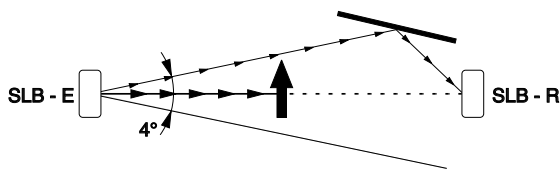

Fig. 1a: safety function inoperative

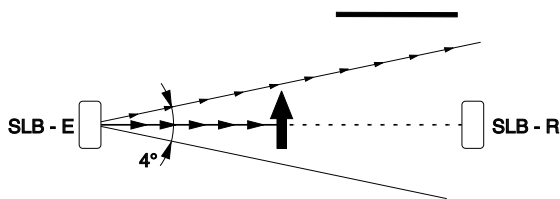

Fig. 1b: safety function operational

4. Electrical connection

4.1 Wiring example



The electrical connection may only be carried out by authorised personnel in a de-energised condition. The reset button must be positioned outside of the hazardous area so that the operator has an overview of the hazardous area when actuating the reset button.

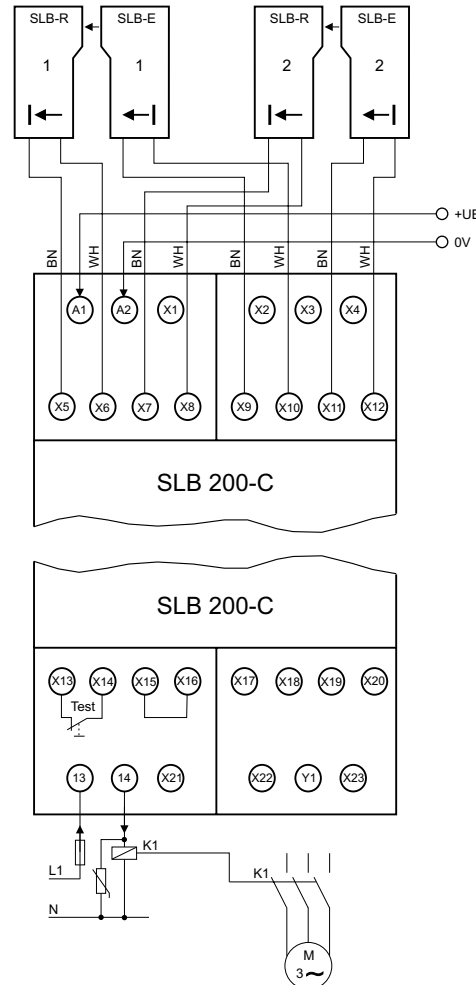

Fig. 2



Inductive loads to be suppressed by means of a suitable circuit.

The signalling output Y1 must not be integrated in the safety circuit.



To avoid any mutual interference, every transmitter / receiver must be connected by means of a separate cable. If multiple light barriers are connected to a cable, a cable with individual conductor shielding must be used.

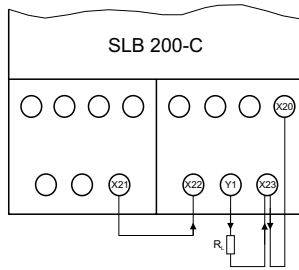

Fig. 3

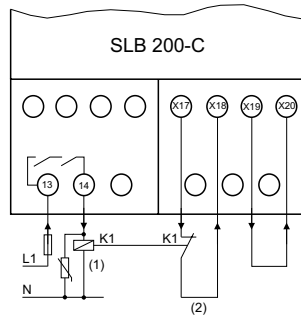

Fig. 4

Key (Fig. 4)

- (1) Contactor
- (2) Contactor control



If the contactor control is not used, a bridge must be established between the terminals X17 and X18!

4.2 Connection example

Operating voltage

Pin	Function
A1	+ UB operating voltage
A2	- UB operating voltage

Safety-monitoring module

Pin	Function
13	Safety output/enabling path
14	Safety output/enabling path

Light barriers

Pin	Function	Conductor colour
X5	Light barrier 1 - receiver (+)	BN
X6	Light barrier 1 - receiver (-)	WH
X7	Light barrier 2 - receiver (+)	BN
X8	Light barrier 2 - receiver (-)	WH
X9	Light barrier 1 - transmitter (+)	BN
X10	Light barrier 1 - transmitter (-)	BK
X11	Light barrier 2 - transmitter (+)	BN
X12	Light barrier 2 - transmitter (-)	BK

Signalling output

Pin	Function	Notes
Y1	Signalling output	
X20	- voltage tap (for contactor control and signalling output)	only for internal -UB
X21	+ voltage tap (for signalling output)	only for internal +UB
X22	Supply signalling output (+)	
X23	Supply signalling output (-)	

Test input

Pin	Function	Notes
X13	+ voltage tap (for test input)	only for internal +UB
X14	Test input (+)	
X15	Test input (-)	
X16	- voltage tap (for test input)	only for internal -UB

Contactor control

Pin	Function	Notes
X17	+ voltage tap (for contactor control)	only for internal +UB
X18	Contactor control (+)	
X19	Contactor control (-)	
X20	- voltage tap (for contactor control and signalling output)	only for internal -UB

Enabling signal (restart)

Pin	Function	Notes
X1	+ voltage tap (for enabling switch)	only for internal +UB
X2	Enabling switch - restart (+)	
X3	Enabling switch - restart (-)	
X4	- voltage tap (for enabling switch)	only for internal -UB



If the contactor control is not used, a bridge must be established between the terminals X17 and X18!

5. Set-up and maintenance

5.1 Functional testing

The safety function of the safety components must be tested. The following conditions must be previously checked and met:

1. Correct assembly of the safety light barriers.
2. Check the integrity of the cable entry and connections.
3. Check the safety light barrier's and the safety-monitoring module's enclosure for damage.
4. If one or more light barriers are interrupted, the hazardous movement is brought to standstill.
5. The safety distance of the application exceeds the mathematically calculated one.

5.3 Maintenance

In the case of correct installation and adequate use, the safety switchgear features maintenance-free functionality. A regular visual inspection and functional test, including the following steps, is recommended:

1. Check the correct mounting of the fixing screws on the safety light barriers.
2. Clean the optics of transmitter and receiver with a soft clean cloth. The use of aggressive, abrasive or scratching cleaning agents, which could attack the surface, is prohibited.
3. The total response time of the machine does not exceed the response time calculated during the first putting into operation.

Damaged or defective components must be replaced.

6. Disassembly and disposal

6.1 Disassembly

The safety switchgear must be disassembled in a de-energised condition only.

6.2 Disposal

The safety switchgear must be disposed of in an appropriate manner in accordance with the national prescriptions and legislations.

5.2 Diagnostics / Fault rectification

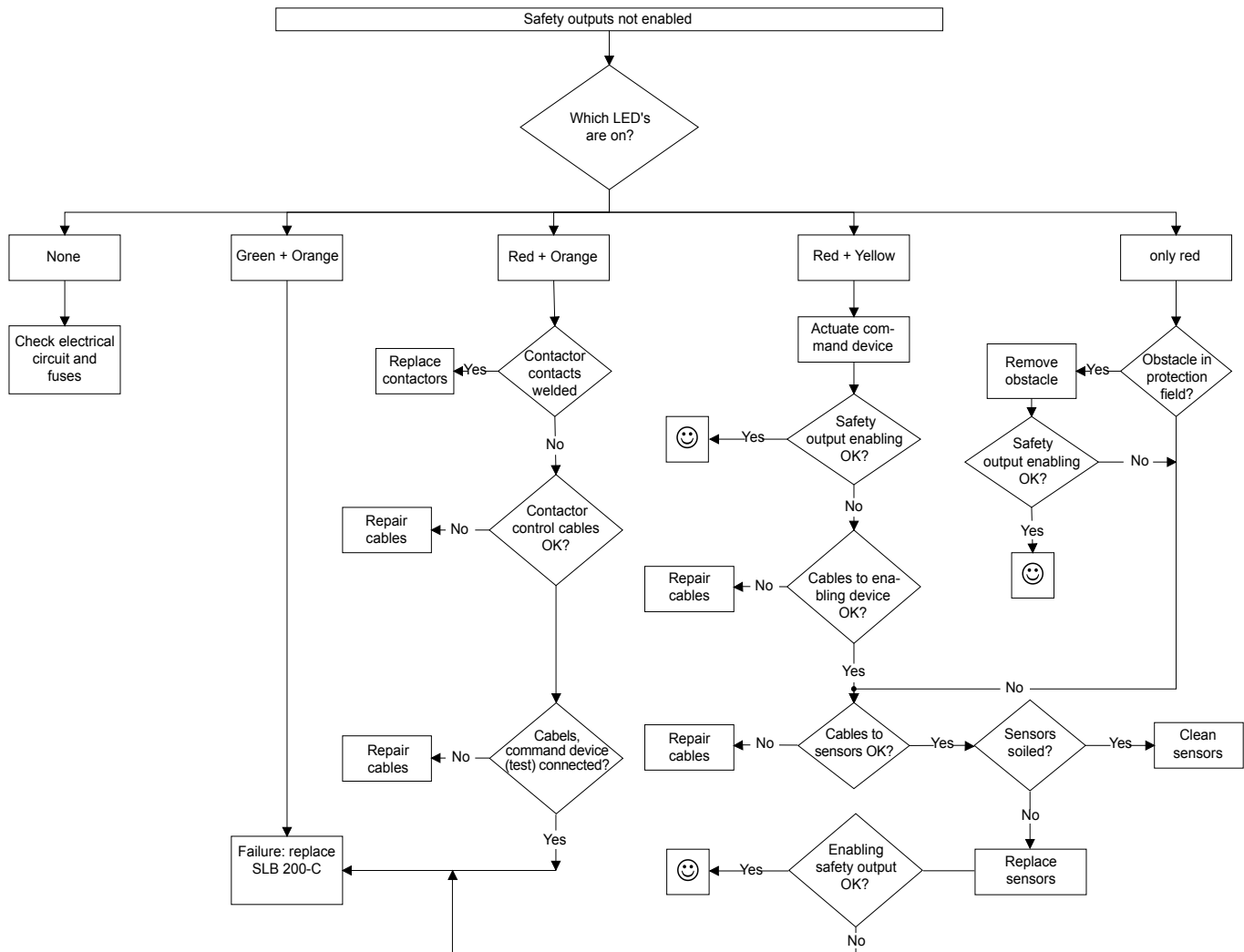

7. Declaration of conformity

7.1 EC Declaration of conformity

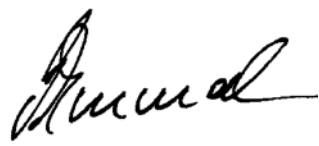
	
<h2>EC Declaration of conformity</h2>	
Translation of the original Declaration of Conformity	K.A. Schmersal GmbH & Co. KG Möddinghofe 30 42279 Wuppertal Germany Internet: www.schmersal.com
We hereby certify that the hereafter described safety components both in its basic design and construction conform to the applicable European Directives.	
Name of the safety component:	SLB 200-C04-1R (in combination with SLB 200-E/R-31-21)
Description of the safety component:	Electro-sensitive safety device with non-contact operating principle
Relevant EC-Directives:	2006/42/EC EC-Machinery Directive 2004/108/EC EMC-Directive
Applied standards:	EN 61496-1:2004 + A1:2008 EN ISO 13849-1:2008/AC:2009 EN 61508, -1-7:2010 CLC/TS 61496-2:2006 EN 62061:2005+A1:2013
Person authorised for the compilation of the technical documentation:	Oliver Wacker Möddinghofe 30 42279 Wuppertal
Notified body for the prototype test:	TÜV Nord Cert. GmbH Langemarckstr. 20 45141 Essen ID n°: 0044
EC-prototype test certificate:	n° 44 205 13 166206
Place and date of issue:	Wuppertal, April 21, 2015
SLB200-C-C-EN	
	Authorised signature Philip Schmersal Managing Director



The currently valid declaration of conformity can be downloaded from the internet at www.schmersal.net.



K. A. Schmersal GmbH & Co. KG
Möddinghofe 30, D - 42279 Wuppertal
Postfach 24 02 63, D - 42232 Wuppertal

Phone: +49 - (0)2 02 - 64 74 - 0
Telefax: +49 - (0)2 02 - 64 74 - 1 00
E-Mail: info@schmersal.com
Internet: <http://www.schmersal.com>