



ECOLAB

Model number

ASSB-4P-SW-V1

Splitter box G10, AS-Interface and auxiliary voltage each to double terminals

Features

- One piece housing
- Simple and fast mounting
- High current rating
- Gold-plated and machined contacts

Dimensions

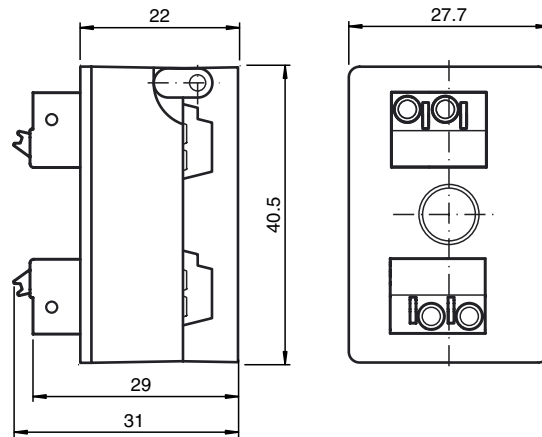

Electrical connection

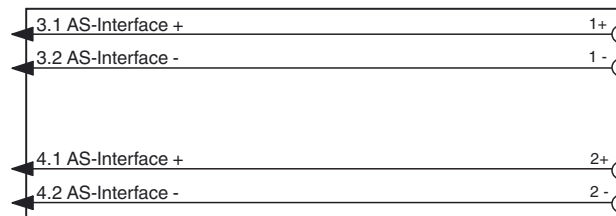

Technical data

General specifications

Construction type	Spring terminal flat cable terminals AS-Interface/auxiliary voltage
-------------------	--

Electrical specifications

Rated operational voltage	U_e	≤ 32 V PELV (AS-Interface , ext. auxiliary voltage AUX)
Rated operational current	I_e	≤ 8 A AS-Interface, ≤ 8 A AUX
Protection class		III
Overvoltage protected		overvoltage category III
Pulse withstand voltage		800 V

Ambient conditions

Ambient temperature	-25 ... 75 °C (-13 ... 167 °F)
Storage temperature	-25 ... 85 °C (-13 ... 185 °F)
Pollution Degree	2

Mechanical specifications

Protection degree	IP20
Connection	Flat cable AS-Interface: cable piercing method Flat cable ext. auxiliary voltage U_{AUX} : Insulation penetration technology Spring terminal

Material

Contacts	CuSn / Au
Housing	PBT PC
Mounting screw	Stainless steel 1.4305 / AISI 303
Mass	40 g
Tightening torque, fastening screws	1.65 Nm

Compliance with standards and directives

Standard conformity	
Protection degree	EN 60529:2000

K.A. Schmersal GmbH & Co. KG
Mödinghofe 30, D - 42279 Wuppertal
Postfach 24 02 63, D - 42232 Wuppertal

Phone: +49 - (0)2 02 - 64 74 - 0
Telefax +49 - (0)2 02 - 64 74 - 1 00
E-Mail: info@schmersal.com
Internet: <http://www.schmersal.com>



Notes**Mounting instructions**

You may screw the device onto a level mounting surface using two M4 attachment screws. The attachment screws are not included.

