



ECOLAB

Model number

ASSB-2P-FKB-V1

Splitter box G10, flat cable to flat cable

Features

- One piece housing
- Simple and fast mounting
- High current rating
- Gold-plated and machined contacts
- Protection degree IP68/IP69K

Dimensions

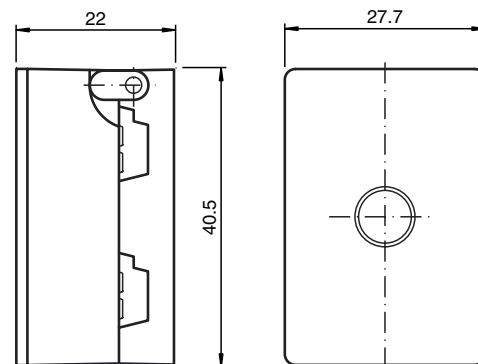

Electrical connection

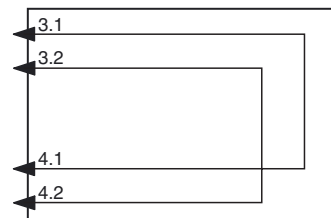

Technical data

General specifications

Construction type	Flat cable terminals
-------------------	----------------------

Electrical specifications

Rated operational voltage	U_e	≤ 32 V PELV
Rated operational current	I_e	≤ 8 A
Protection class		III
Overvoltage protected		overvoltage category III

Ambient conditions

Ambient temperature	-25 ... 75 °C (-13 ... 167 °F)
Storage temperature	-25 ... 85 °C (-13 ... 185 °F)
Pollution Degree	3

Mechanical specifications

Protection degree	IP67
Connection	Flat cable: cable piercing method
Material	
Contacts	CuSn / Au
Housing	PBT PC
Mounting screw	Stainless steel 1.4305 / AISI 303
Mass	40 g
Tightening torque, fastening screws	1.65 Nm

Compliance with standards and directives

Standard conformity	
Protection degree	EN 60529:2000

K.A. Schmersal GmbH & Co. KG
 Möddinghofe 30, D - 42279 Wuppertal
 Postfach 24 02 63, D - 42232 Wuppertal

Phone: +49 - (0)2 02 - 64 74 - 0
 Telefax: +49 - (0)2 02 - 64 74 - 1 00
 E-Mail: info@schmersal.com
 Internet: <http://www.schmersal.com>



Notes**Mounting instructions**

You may screw the device onto a level mounting surface using two M4 attachment screws. The attachment screws are not included.

