

**Installation manual
for
PSC1 field buses
EtherNet/IP
PROFINET IO
EtherCAT

and
PROFIBUS
CANopen**

Installation manual for PSC1 field buses: EtherNet/IP, PROFINET IO, EtherCAT, PROFIBUS und CANopen

Note:

The German version is the original version of the installation instructions.

As of: 04/2022

Subject to technical change without notice.

The content of our documentation has been prepared with the greatest possible care and corresponds to the latest information available to us.

Nevertheless, we draw your attention to that fact that this document cannot always be updated simultaneously with the technical further development of our products.

Information and specifications may be changed at any time. Please obtain information on the latest version at: www.schmersal.net.

K. A. Schmersal GmbH & Co. KG
Möddinghofe 30
42279 Wuppertal

Contents

- 1 IMPORTANT NOTES 6**
- 1.1 Definitions 6
- 1.2 Other applicable documents..... 6
- 1.3 Abbreviations used 7
- 2 SAFETY INSTRUCTIONS 8**
- 2.1 Intended use..... 8
- 2.2 General safety instructions 8
- 2.3 Operating and service 9
- 2.4 Transport/storage 9
- 3 DEVICE DESCRIPTION AND FUNCTION 10**
- 3.1 Fieldbus-specific properties 11
- 3.1.1 EtherNet/IP 11
- 3.1.2 PROFINET IO 12
- 3.1.3 EtherCAT 12
- 3.1.4 PROFIBUS 13
- 3.1.5 CANopen 14
- 4 EQUIPMENT AND SETTINGS 15**
- 4.1 Ethernet-based device variants (-FB1) 15
- 4.2 CAN or RS485-based device variants (-FB2) 16
- 4.3 Diagnostic LEDs..... 17
- 5 CONNECTION AND INSTALLATION 19**
- 5.1 General installation instructions 19
- 5.2 Installing PSC1 modules 20
- 5.3 Assembly of modules and backplane bus 21
- 5.4 Address selector switch 21
- 5.5 Assignment of connection socket 22
- 5.5.1 Fieldbus interface connection socket with the FB1 option (RJ45 socket) 22
- 5.5.2 Fieldbus interface connection socket with the FB2 option (D-SUB- socket) 22
- 6 MODIFICATION / DEALING WITH CHANGES TO THE DEVICE 22**
- 7 MAINTENANCE 23**
- 7.1 Replacement of a module..... 23
- 8 TECHNICAL DATA 23**
- 8.1 Ambient conditions 23
- 9 INPUT/OUTPUT DATA..... 24**
- 9.1 PSC1-C-10-x-FB1/2 24
- 9.1.1 Input data 24
- 9.1.2 Output data 26
- 9.2 PSC1-C-100-x-FB1/2 27
- 9.2.1 Input data 27
- 9.2.1.1 Structure for device profile 0 (= free assignment) 27
- 9.2.1.2 Structure for device profile 1 (= only logic data) 31
- 9.2.1.3 Structure for device profile 2 (= logic data + process data for each slave) 32
- 9.2.2 Output data 34
- 9.3 SD-Bus data 35
- 9.3.1 Fieldbus data SD-Bus Gateway 35
- 9.3.2 Fieldbus data SD slave..... 35
- 9.3.3 Structure of the SD bytes in the fieldbus protocol 36
- 9.3.4 Reading acyclic data from the SD slave..... 37
- 10 ASSIGNING IP ADDRESS (-FB1 OPTION ONLY)..... 40**
- 11 COMMISSIONING AND CONFIGURATION PROFINET IN SAFEPLC2 AND TIA PORTAL (FROM STEP 7 V10) 42**
- 11.1 Parameter configuration..... 47

- 11.1.1 Installing the XML file 47
- 11.1.2 Create project and insert PSC1 with PROFINET 49
- 11.1.3 Setting up safe data transmission 53
- 11.1.4 Setting up an online connection 55
- 11.1.5 Examples of non-safe data transmission 61
- 11.1.6 Examples of safe data transmission..... 64
- 12 COMMISSIONING AND CONFIGURATION ETHERNET/IP IN SAFEPLC2 AND RSLOGIX500..... 66**
- 12.1 Parameter configuration..... 70**
- 12.1.1 Create project 70
- 12.1.2 Installing the EDS file 73
- 12.1.3 Insert PSC1 77
- 12.1.4 Setting up an online connection 81
- 12.1.5 Examples of non-safe data transmission 84
- 12.2 Assigning IP addresses with the BOOTP-DHCP tool..... 86**
- 12.3 Assigning IP addresses using the IP administrator 89**
- 12.4 Explicit Messaging 92**
- 13 COMMISSIONING AND CONFIGURATION ETHERCAT IN SAFEPLC2 AND TWINCAT 3..... 93**
- 13.1 Parameter configuration..... 98**
- 13.1.1 Create project and search for target system 98
- 13.1.2 Find connected I/O devices 101
- 13.1.3 EoE 105
- 13.1.4 Examples of non-safe data transmission 106
- 13.1.5 Create safety project 111
- 14 COMMISSIONING AND CONFIGURATION PROIFBUS IN SAFEPLC2 AND TIA PORTAL (FROM STEP 7 V10) 134**
- 14.1 Parameter configuration..... 139**
- 14.1.1 Create project and insert PSC1 with PROFIBUS 142
- 14.1.2 Setting up safe data transmission 147
- 14.1.3 Setting up non-safe data transmission 149
- 14.1.4 Setting up an online connection 151
- 14.1.5 Examples of non-safe data transmission 155
- 14.1.6 Examples of safe data transmission..... 158
- 14.1.7 Examples of safe data transmission..... 159
- 15 COMMISSIONING AND CONFIGURATION CANOPEN IN SAFEPLC2 AND CODESYS..... 161**
- 15.1 Integrating the device description file 163**
- 15.2 Creating a new project..... 164**

Change history

Version no.	Date	Change comments
V 1.0	23/11/2016	Approved
V 1.1	19/01/2017	Change Table 16 / Byte order error code, concerns byte 3 and 4, high and low byte exchanged
V 1.2 – 1.4	16/03/2018	Project planning examples added (Sections 10 - 13)
V 1.5	06/04/2018	Editorial changes
V 2.0	04/05/2018	Chapter 9.3 SD-Bus data added
V 2.1	18/07/2018	CANopen added
V 2.2	16/09/2019	Commissioning CANopen added, Description IP-Administrator added
V 2.3	18/05/2020	Ethernet/IP Explicit messaging added
V 2.4	03/2021	Editorial changes Note for Npcap added Tables for diagnostic bytes reworked
V2.5	04/2022	Editorial changes MAC-Address Adding EoE chapter Rework chapter PSC1-C-10 in/output data

1 Important notes

Definition of the individual target groups:

Design of safe drive systems:

- Engineers and technicians

Mounting, electrical installation, maintenance and device replacement:

- Industrial electricians and service engineers

Commissioning, operation and configuration:

- Technicians and engineers

1.1 Definitions

The term PSC1 is used as the generic term for all derivatives of the PSC1 product line. If reference is made to a specific derivative in the description, the complete identifier is used.

COM is the abbreviation for the universal communication interface of the PSC1.

The term "safe" used in the following refers to categorisation as a safe function for usage from PL b according to EN ISO 13849-1 or SIL1 according to EN 61508.

The programming software "SafePLC2" is used to configure and program the PSC1 modules.

1.2 Other applicable documents

<i>Description</i>	<i>Reference</i>
General information on PSC1 modules and their use	Installation manual PSC1-C-10, Installation manual PSC1-C-100, Programming manual SafePLC2

Table 1: Other applicable documents

 **Note:**

- Read manuals carefully before you start the installation and commissioning of the PSC1 module.
- Following the documentation is a prerequisite for trouble-free operation and the acceptance of claims under the warranty.

1.3 Abbreviations used

Abbreviation	Meaning
AC	Alternating Current
IL	Instruction List
BGIA (IFA)	Institute for Industrial Safety at the German statutory accident prevention body
CLK	Clock
CPU	Central Processing Unit
DC	Direct Current
DIN	Deutsches Institut für Normung
EDS	Electronic Data Sheet - EtherNet/IP
EMC	Electro Magnetic Compatibility
EN	European Norm
ESI	EtherCAT XML Device Description
ETG	EtherCAT Technology Group
GSD	General Station Description
GSDML	General Station Description Markup Language
IPxx	Degree of protection for housing
ISO	International Organisation for Standardisation
LED	Light Emitting Diode
PLC	Programmable Logic Controller
POR	Power on Reset
SDDC	Safe Device To Device Communication
SELV	Safety Extra Low Voltage
SSI	Synchronous Serial Interface
VDE	Verband der Elektrotechnik, Elektronik und Informationstechnik e. V.

Table 2: Abbreviations

2 Safety instructions

2.1 Intended use

The universal communication interface COM is an extension for the modules PSC1-C-10-x-FB1, PSC1-C-10-x-FB2, PSC1-C-100-FB1, PSC1-C-100-FB2 and their variants for non-safe data transmission via an Ethernet, or CAN or RS485 based protocol.

The COM interface also has the following options:

- Safe data transmission via safe fieldbus protocols
- Safe Remote I/O Communication (SDDC)
- Safe cross communication (SMMC)
- SD bus communication

These options are described in separate manuals.

The option: Memory Card (SDHC) is described in the PSC1-C-10/100 installation manuals.

2.2 General safety instructions

Safety instructions:

- To prevent injury and damage, only qualified personnel are allowed to work on the device. Qualified personnel are personnel who have electrical engineering apprenticeship and who are familiar with the applicable rules and standards of electrical engineering.

The qualified person must become familiar with the operating instructions (cf. IEC 364, DIN VDE0100).

- The qualified person must have, as a minimum, detailed knowledge of national health and safety regulations.
- The usage of the devices is to be limited to their intended usage as per the list given above. The values in the data listed in Section "3. Device description and function" are also to be met.
- The content of these installation instructions is limited to the basic function of the devices and their installation. The programming of the devices and re-configuration of the device parameters is further described in the "Programming manual SafePLC2". Detailed knowledge and understanding of this information is a vital prerequisite for a new installation or the modification of the device function or device parameters.
- Commissioning (i.e. commencing operated as intended) is only allowed on compliance with the EMC directive.
- It is imperative that the wiring and connection notes from the Sections "0.

- *Equipment and settings*" and "5. *Connection and installation*" are followed.
- The applicable VDE regulations as well as other special safety regulations for the specific application are to be followed.
- Never install or place in operation damaged products. Please report damage to the carrier without delay.
- Never open the housing and/or make unauthorised modifications.
- Inputs and outputs for standard functions and the digital and analogue data transmitted via communication modules are not allowed to be used for safety-related applications.

 **WARNING:**

The usage of our devices contrary to the rules and conditions stated here can result in the injury or the death of persons, as well as damage to the devices and machines connected!

This usage will also render void any claim under the warranty or any claim for claim damages against K.A. Schmersal GmbH & Co. KG.

2.3 Operating and service

Prior to installing and removing the module, or disconnecting the signal wires, the module is to be electrically isolated. For this purpose, all electrically live supply wires to the device are to be switched off and it is to be checked that there is no electrical power present on the wires.

During the installation and removal of the module, appropriate measures are to be taken to prevent electrostatic discharges on the external terminals and connections. Contact with these terminals should therefore remain limited to a minimum; prior to and during this work you should be earthed, e.g. using an earthing wrist strap.

2.4 Transport/storage

The instructions on transport, storage and correct handling are to be followed. The climatic specifications as per the Section "8. *Technical data*" are to be met.

3 Device description and function

The universal communication interface COM is permanently integrated in each basic module with the option FB1 or FB2.

In this connection, the COM interface is responsible for non-safe data transmission via Ethernet or CAN or RS485-based bus protocols.

Depending on option FB1 (EtherNet/IP, PROFINET, EtherCAT) or FB2 (PROFIBUS, CANopen), all fieldbus protocols associated with the options are stored in the COM interface.

These can be selected and configured in SafePLC2. Type and number of data are also defined in SafePLC2. For PSC1-C-100-FBx systems, a choice of 3 different transmission profiles is also available.

Please observe the notes in the corresponding chapters in the "SafePLC2 Programming Manual".

The COM interface receives data from the application program running on the PSC1 and forwards it to a higher-level standard controller via the bus protocol selected and configured in the SafePLC2 programming system.

The data can be further processed there. The non-safe diagnostic data consist of logic data and process data.

The process data can contain position values, speeds and other analogue values of the axis monitoring modules, which are either integrated into the basic module (PSC1-C-10-x-FBx) or connected to it via the backplane bus (PSC1-C-100-FBx).

In addition, up to 32 non-safe functional inputs are available on the PSC1, via which digital information can be received from the higher-level standard controller.

In the "SafePLC2" function diagram, these inputs must be AND-linked to a safe input and can then be reused as required.

For a detailed breakdown of diagnostic data and pre-selectable profiles, please refer to Section 9. Input/Output data.

The basic module equipped with a COM interface is always a slave in the network.

A corresponding device description file (EDS, GSDML, ESI, GSD) is required for configuration within the programming system of the higher-level controller.

With EtherNet/IP, the base module can also be configured as a generic Ethernet device.

3.1 Fieldbus-specific properties

Note: The MAC-Address printed on the devices represents the MAC-Address of the SDDC connection ports. The MAC-Address of the fieldbus ports is derived following the example:

00:16:22:**22**:12:34

00:16:22:**A2**:12:34

& 80h

3.1.1 EtherNet/IP

Response time	Processing time for incoming fieldbus protocols: min.1 ms; Response time depends on the PSC1 system: see installation manual PSC1
Maximum number of output data (O → T)	68 bytes (1)
Maximum number of input data (T → O)	192 bytes (2)
IO connection types (implicit)	Exclusive Owner, Listen Only, Input Only
Max. number of connections	8 (sum of the connected explicit and implicit connections)
Supported standard objects	Identity Object (0x01) Message Router Object (0x02) Assembly Object (0x04) Connection Manager (0x06) DLR Object (0x47) QoS Object (0x48) TCP/IP Interface Object (0xF5) Ethernet Link Object (0xF6) Time Sync Object (0x43)
Baud rates	10 and 100 Mbps
Data transmission	Half duplex, full duplex, auto-negotiation
Data transport layer 100 MBit/s	Ethernet II, IEEE 802.3
ACD (Address Conflict Detection)	Supported
DLR V2 (Device-Level-Ring topology)	Supported
Quick Connect	Supported
CIP sync	Supported
Integrated switch	Supported
Reset services	Identity Object Reset Service of Type 0 and 1
DHCP	Supported
BOOTP	Supported

Table 3: Fieldbus-specific properties EtherNet/IP

- (1) Outputs 4 byte; SD bus outputs: 64 byte
 (2) Diagnostic inputs: 128 byte; SD bus inputs: 64 byte

3.1.2 PROFINET IO

Response time	Processing time for incoming fieldbus protocols: min.1 ms; Response time depends on the PSC1 system: see installation manual PSC1
Number of output data (cyclic)	80 bytes (1)
Number of input data (cyclic)	204 bytes (2)
Baud rates	100 MBit/s
Supported protocols	RTC – (Real time cyclic protocol (Class 1, Class 2, Class 3)) RTA – (Real time acyclic protocol) DCP – (Discover and Configuration Protocol) LLDP – (Link Layer Discovery Protocol)
Topology detection	LLDP, SNMP V1, MIB2, physical device
Data transmission	Half duplex, full duplex, auto-negotiation
Data transport layer 100 MBit/s	Ethernet II, IEEE 802.3

Table 4: Fieldbus-specific properties PROFINET

- (1) Outputs 4 byte; SD bus outputs: 64 byte; safe outputs: 12 byte
- (2) Diagnostic inputs: 128 byte; SD bus inputs: 64 byte; safe inputs: 12 byte

3.1.3 EtherCAT

Response time	Processing time for incoming fieldbus protocols: min.1 ms; Response time depends on the PSC1 system: see installation manual PSC1
Number of output data (cyclic)	95 bytes (1)
Number of input data (cyclic)	219 bytes (2)
Baud rates	100 MBit/s
Type	Complex slave
Number of sync managers	4 (2 acyclic, 2 cyclic)
Distributed clock	supported, 32 bit
Supported protocols	CoE EoE
Data transmission	Half duplex, full duplex, auto-negotiation
Data transport layer 100 MBit/s	Ethernet II, IEEE 802.3

Table 5: Fieldbus-specific properties EtherCAT

- (1) Outputs 4 byte; SD bus outputs: 64 byte; safe outputs: 27 bytes (3)
- (2) Diagnostic inputs: 128 byte; SD bus inputs: 64 byte; safe inputs: 27 bytes (3)
- (3) 12 bytes user data + 12 bytes CRC + 2 bytes Connection ID + 1 byte Master Command

3.1.4 PROFIBUS

Response time	Processing time for incoming fieldbus protocols: min.1 ms; Response time depends on the PSC1 system: see installation manual PSC1
Number of output data (cyclic)	80 bytes (1)
Number of input data (cyclic)	204 bytes (2)
Device class	DP Slave
Baud rates	9.6 kBit/s up to 12 MBit/s
Supported state machines	FSPMS, MSCY1S, DMPMS, MSAC1S, MSAC2S, MSRM2S
Data transport layer	PROFIBUS FDL
Freeze Mode	Supported
Sync Mode	Supported
Auto baud rate	Supported

Table 6: Fieldbus-specific properties PROFIBUS

- (1) Outputs 4 byte; SD bus outputs: 64 byte; safe outputs: 12 byte
 (2) Diagnostic inputs: 128 byte; SD bus inputs: 64 byte; safe inputs: 12 byte

3.1.5 CANopen

Response time	Processing time for incoming fieldbus protocols: min.1 ms; Response time depends on the PSC1 system: see installation manual PSC1
Number of output data (cyclic)	68 Byte ⁽¹⁾
Number of input data (cyclic)	192 Byte ⁽²⁾
Number of RPDO	5
Number of TPDO	20
Exchange of process data	via PDO
Acyclic communication	via SDO Emergency message (producer), Timestamp (producer/consumer)
Baud rates	10 kBit/s to 1 MBit/s
Functions	Node guarding, life guarding, Heartbeat, PDO Mapping NMT Slave SYNC protocol (consumer) Error behavior in state operational: <ul style="list-style-type: none"> • change to state pre-operational • no state change • change to state stopped
Data transport	CAN Frames
CAN Frame Typ	11 Bit 11/29 Bit Layer 2 transparent
Sync Mode	Supported
Auto baud rate	Supported

Table 7: Fieldbus-specific properties CANopen

4 Equipment and settings

4.1 Ethernet-based device variants (-FB1)

The front panel of the Ethernet-based fieldbus variants displays the following equipment:

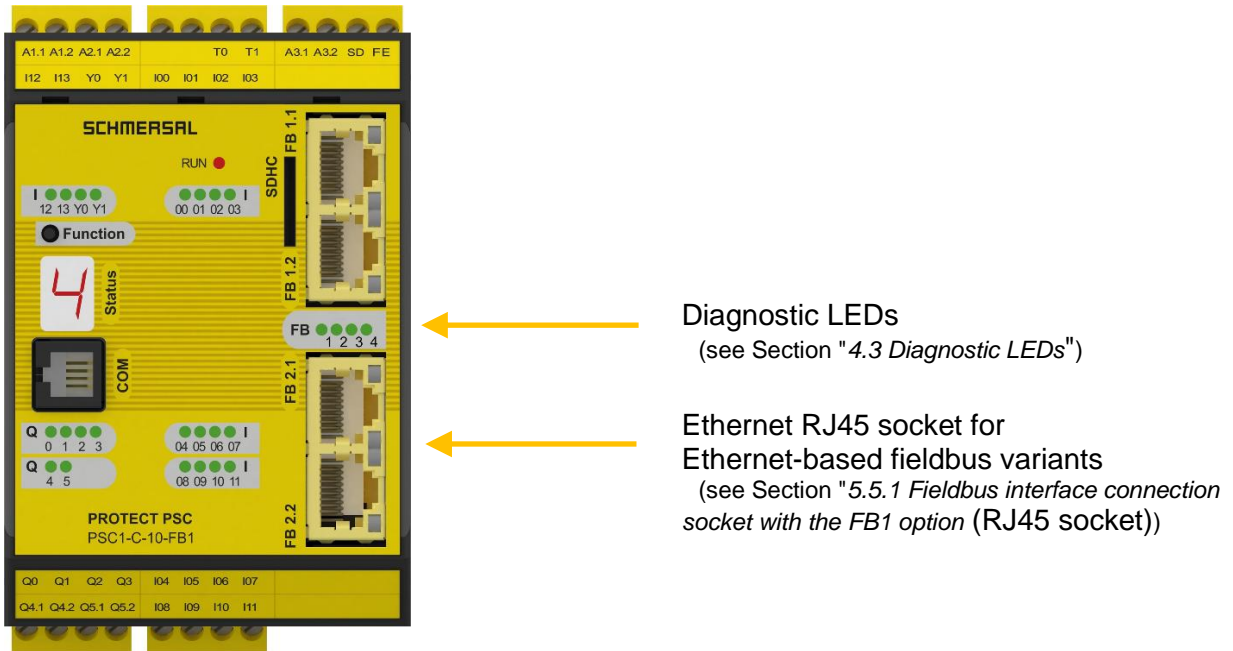

Figure 1: Front view device variant (-FB1); here PSC1-C-10-FB1

No settings have to be made on the device.

4.2 CAN or RS485-based device variants (-FB2)

The front panel of the CAN or RS485-based fieldbus variants displays the following equipment:

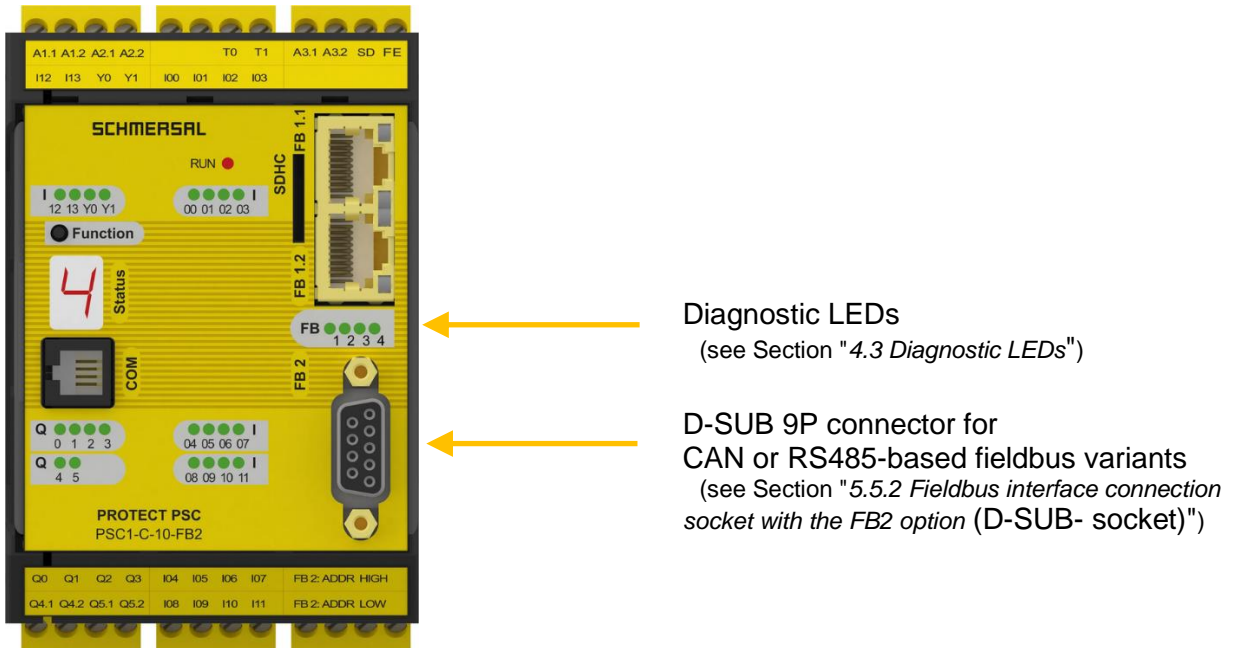
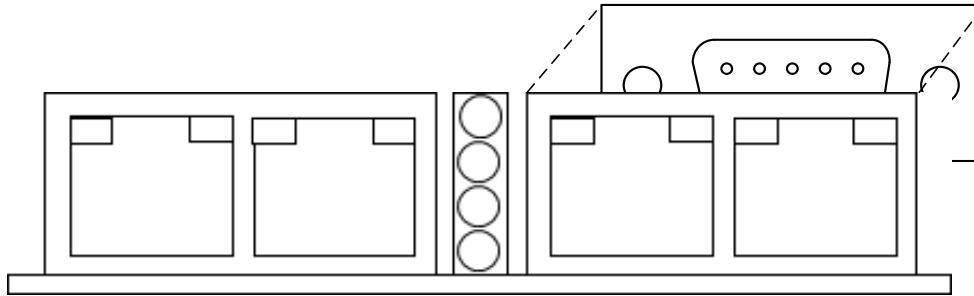

Figure 2: Front view device variant (-FB2); here PSC1-C-10-FB2

The slave address must be adapted according to Section 5.4 "Address selector switch"

4.3 Diagnostic LEDs

The universal communication interface has 4 two-colour LEDs, independent of the device variant, with which the signal colours orange, green and red are displayed.



	No.	Name	Function
	4	Run	PSC1 State SDDC/SMMC communication
	3	Bus	Fieldbus status
	2	XB	Cross communication to the F-CPU
1	SD	SD bus status	

Figure 3: Diagnostic LEDs

The following table shows the display functions:

4 / Run	orange	Flashing	Initialisation; waiting for connection and reception of the device and connection parameters
		Continuous	Wait for logical link to Master-COM
	Green	Flashing	Waiting for reception of the device and connection parameters after a time-out from the master run
		Continuous	Active process data exchange
	Red	Continuous	No link on either port; Timeout of the connection from the start-up or master restart state
3 / Bus	Green	Continuous	EtherNet/IP: Connected PROFINET IO: Application relationship (AR) established; active EtherCAT: Status operational PROFIBUS: Connection active CANopen: Status operational
		Flashing	EtherNet/IP: - PROFINET IO: Bus Link, but no integration EtherCAT: Status preoperational PROFIBUS: Bus Link, but no integration CANopen: Status preoperational
		short pulse	EtherNet/IP: Waiting for connection to the scanner (bridge) PROFINET IO: Bus Link, but no integration EtherCAT: Status Safe operational PROFIBUS: - CANopen: -
	Red	Continuous	EtherNet/IP: Timeout PROFINET IO: Bus error EtherCAT: Application Controller Failure PROFIBUS: Bus error CANopen: Application Controller Failure
		Flashing	EtherNet/IP: - PROFINET IO: Bus error EtherCAT: Error code according to ETG.1300 EtherCAT indicator and labelling specification PROFIBUS: Bus error CANopen: -
	orange	Flashing	EtherNet/IP: Network/link error; same IP address used PROFINET IO: - EtherCAT: - PROFIBUS: -
	off	-	EtherNet/IP: Not active; no MAC address; not initialised PROFINET IO: inactive EtherCAT: inactive / status initialisation PROFIBUS: inactive
	2 / XB	Green	Continuous
Red		Continuous	Fault: Timeout for SPI connection to F-CPU
1 / SD	Green	Flashing	SD bus scan active
		Continuous	Active data exchange
	Red/orange	Flashing	Error during SD bus scan
	Red	Continuous	SD bus error in cyclic operation
	off	-	No SD bus device (slave) found

Table 8: Diagnostic LEDs display functions

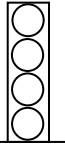
5 Connection and installation

The COM interface requires no additional power supply for safe and non-safe fieldbus communication. The interface is supplied directly by the base module.

The bus systems must be installed in accordance with the respective installation instructions of the user organisations (ODVA, PNO, ETG, CiA).

The fieldbuses must always be connected to the RJ45 sockets marked FB2.1 / FB2.2 (option FB1) or to the D-SUB socket marked FB2 (option FB2), as shown as an example in the following figure.

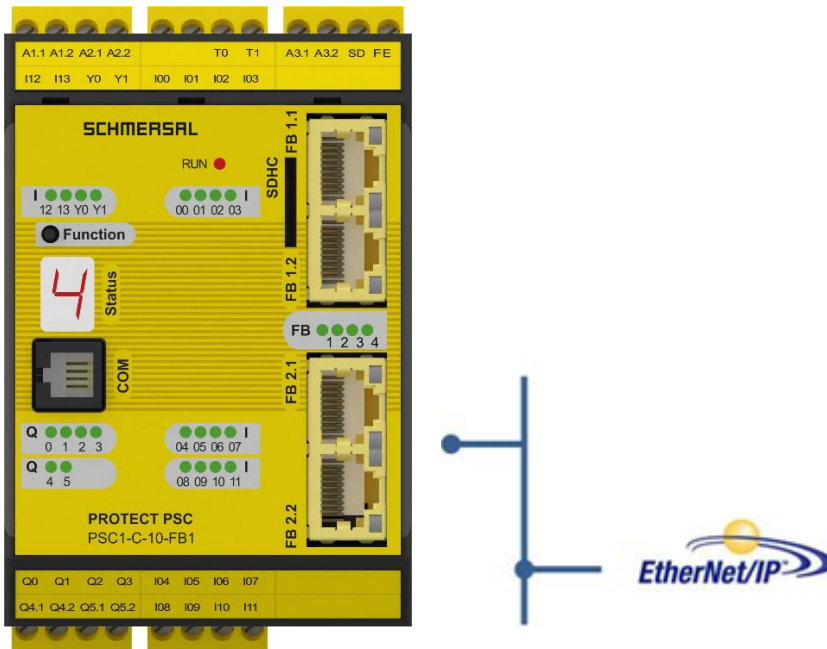

Figure 4: Example for fieldbus connection to the FB2.1 / FB2.2 (EtherNet/IP) sockets

A 2-port switch functionality is integrated for EtherNet/IP or PROFINET.

5.1 General installation instructions

It is imperative you follow the safety instructions during installation!

Degree of protection IP20

In all circumstances separate voltages of 230 VAC from low-voltage wires, if these voltages are used in relation to the application.

Suitable measures must be taken to exclude faults in the event of overvoltage. Suitable measures are, for instance, lightning protection for wires outdoors, overvoltage protection for the installation indoors, protected cable laying.

Measures for electromagnetic compatibility (EMC):

PSC1 modules are intended to be used with drives and meet the EMC requirements stated above.

In addition, it is a prerequisite that the electromagnetic compatibility of the overall system is safeguarded using customary measures.

Safety instructions:

- It is to be ensured that the power supply wires for the PSC1 and "switching wires" for the power converter are laid separately.
- Signal wires and power wires for the power converter are to be laid in separate cable ducts. The distance between the cable ducts should be at least 10 mm.
- Attention is to be paid to the correct installation in relation to EMC of the power converter technology in the area of the PSC1 module. Particular attention should be paid to cable routing and the connection of the screen for the motor cable and the connection of brake resistor. Here it is imperative the installation guidelines from the manufacturer of the power converter are followed.
- All contactors in the area of the converter must be equipped with an appropriate suppressor circuit.
- Suitable measures for protection against overvoltages are to be taken.

5.2 Installing PSC1 modules

The module is only installed in switch cabinets that meet degree of protection IP54 as a minimum.

The modules must be fastened vertically on a DIN rail.

The ventilation slots must be kept adequately clear to obtain the circulation of air inside the module.

Further information can be found in the installation manuals for the PSC1-C-10 and PSC1-C-100.

5.3 Assembly of modules and backplane bus



Figure 5: Assembly

The devices are fitted to the rail from above at an angle and snapped downward.

Further information can be found in the installation manuals for the PSC1-C-10 and PSC1-C-100.

5.4 Address selector switch

For PSC1 modules with option FB2, two address selection switches are mounted on the underside of the COM interface.

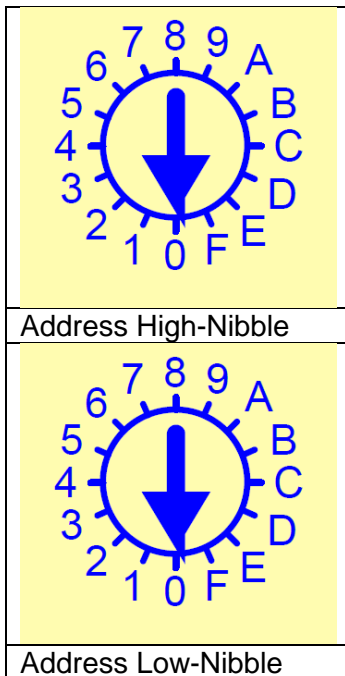

Figure 6: Address selector switch for PSC1 devices with option FB2

5.5 Assignment of connection socket

5.5.1 Fieldbus interface connection socket with the FB1 option (RJ45 socket)

	<table border="1"> <thead> <tr> <th>Pin</th> <th>Name</th> <th>Description</th> <th>Colour</th> </tr> </thead> <tbody> <tr> <td>1</td> <td>TX+</td> <td>Transmit Data +</td> <td>white-orange</td> </tr> <tr> <td>2</td> <td>TX-</td> <td>Transmit Data -</td> <td>orange</td> </tr> <tr> <td>3</td> <td>RX+</td> <td>Receive Data +</td> <td>white-green</td> </tr> <tr> <td>4</td> <td>nc</td> <td>not used</td> <td>blue</td> </tr> <tr> <td>5</td> <td>nc</td> <td>not used</td> <td>white-blue</td> </tr> <tr> <td>6</td> <td>RX-</td> <td>Receive Data -</td> <td>Green</td> </tr> <tr> <td>7</td> <td>nc</td> <td>not used</td> <td>white-brown</td> </tr> <tr> <td>8</td> <td>nc</td> <td>not used</td> <td>brown</td> </tr> </tbody> </table>	Pin	Name	Description	Colour	1	TX+	Transmit Data +	white-orange	2	TX-	Transmit Data -	orange	3	RX+	Receive Data +	white-green	4	nc	not used	blue	5	nc	not used	white-blue	6	RX-	Receive Data -	Green	7	nc	not used	white-brown	8	nc	not used	brown
	Pin	Name	Description	Colour																																	
1	TX+	Transmit Data +	white-orange																																		
2	TX-	Transmit Data -	orange																																		
3	RX+	Receive Data +	white-green																																		
4	nc	not used	blue																																		
5	nc	not used	white-blue																																		
6	RX-	Receive Data -	Green																																		
7	nc	not used	white-brown																																		
8	nc	not used	brown																																		

Figure 7: Fieldbus interface connection socket / FB1 option (RJ45 socket)

5.5.2 Fieldbus interface connection socket with the FB2 option (D-SUB- socket)

	<table border="1"> <thead> <tr> <th>Pin</th> <th>Name</th> <th>Description</th> </tr> </thead> <tbody> <tr> <td>1</td> <td>nc</td> <td></td> </tr> <tr> <td>2</td> <td>CAN_N</td> <td>CAN data line negative (in preparation)</td> </tr> <tr> <td>3</td> <td>PB_P / CCL_P</td> <td>Data line plus (PROFIBUS: B-line)</td> </tr> <tr> <td>4</td> <td>PB-CNTR_P</td> <td>Repeater direction control plus (OPTIONAL)</td> </tr> <tr> <td>5</td> <td>GND Bus</td> <td>Data ground</td> </tr> <tr> <td>6</td> <td>+5V bus</td> <td>5V supply for bus termination</td> </tr> <tr> <td>7</td> <td>CAN_P</td> <td>CAN data line plus (in preparation)</td> </tr> <tr> <td>8</td> <td>PB_N / CCL_N</td> <td>Data line negative (PROFIBUS: A-line)</td> </tr> <tr> <td>9</td> <td>PB-CNTR_N</td> <td>Repeater direction control negative (OPTIONAL)</td> </tr> </tbody> </table>	Pin	Name	Description	1	nc		2	CAN_N	CAN data line negative (in preparation)	3	PB_P / CCL_P	Data line plus (PROFIBUS: B-line)	4	PB-CNTR_P	Repeater direction control plus (OPTIONAL)	5	GND Bus	Data ground	6	+5V bus	5V supply for bus termination	7	CAN_P	CAN data line plus (in preparation)	8	PB_N / CCL_N	Data line negative (PROFIBUS: A-line)	9	PB-CNTR_N	Repeater direction control negative (OPTIONAL)
	Pin	Name	Description																												
1	nc																														
2	CAN_N	CAN data line negative (in preparation)																													
3	PB_P / CCL_P	Data line plus (PROFIBUS: B-line)																													
4	PB-CNTR_P	Repeater direction control plus (OPTIONAL)																													
5	GND Bus	Data ground																													
6	+5V bus	5V supply for bus termination																													
7	CAN_P	CAN data line plus (in preparation)																													
8	PB_N / CCL_N	Data line negative (PROFIBUS: A-line)																													
9	PB-CNTR_N	Repeater direction control negative (OPTIONAL)																													

Figure 8: Fieldbus interface connection socket / FB2 option (D-SUB)

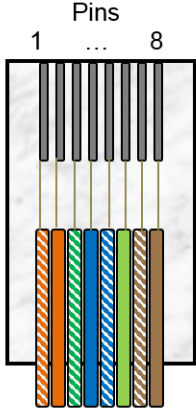
6 Modification / dealing with changes to the device

Repair

It is only possible to repair a device in the factory.

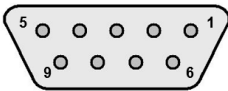
Warranty

The warranty will be rendered void if the module is opened or modified without authorisation.

7 Maintenance

7.1 Replacement of a module

On the replacement of a module the following sequence should be noted:

- Remove power supply
- Remove fieldbus connection cable
- Remove the module from the DIN rail and pack it EMC-compliant
- Install new module on the DIN rail
- Connect the fieldbus connection cable
- Activate power supply

 **Note:**

In principle, no plug-in connection on the PSC1 module is allowed to be disconnected or connected again while electrically live.

8 Technical data

8.1 Ambient conditions

Degree of protection	IP 20
Ambient temperature	0°C... 50 °C
Storage temperature:	-25°C...70°C
Service life	20 years in 50 °C environment

Table 9: Ambient conditions

9 Input/Output data

The first 128 bytes of the input assignment are used for diagnostic data.

The following 64 bytes are used for SD bus data; look to chapter 9.3.

Currently, 128 bytes of diagnostic data are always sent, regardless of how much data the higher-level standard control system actually requires.

Data that are not required by the base device are set with the value 0.

Diagnostic data is composed in SafePLC2.

Irrespective of the device and selected profile, 68 bytes of output data are available. The upper 64 bytes of this are used for the SD bus.

9.1 PSC1-C-10-x-FB1/2

9.1.1 Input data

Structure of the overall frame:

Total diagnostic data size: always 128 bytes, of which 16 bytes can be used for diagnostics

Byte	Bit	"Run" mode (2, 3, 4)	Error case (A, F)
Byte 0	0...3	PSC1 mode 1, 2, 3, 4, 5, 6 = Fatal error, 7 = Alarm	
	4	1	
	5..7	Alive counter (3 Bit)	
Byte 1	0...7	Logic data (Bit ID: 48...55)	
Byte 2	0...7	Logic data (Bit ID: 40...47)	
Byte 3	0...7	Logic data (Bit ID: 32...39)	
Byte 4	0...7	Logic data (Bit ID: 8...15)	
Byte 5	0...7	Logic data (Bit ID: 0...7)	
Byte 6*	0..6	Logic data (Bit ID: 24... 30)	Error code: high Byte
	7	0	1
Byte 7*	0..7	Logic data (Bit ID: 16..23)	Error code: low Byte

Table 10: PSC1-C-10-x-FB1/2 logic data

The bits 'PSC1 mode' show the status of the control. The states 1-5 are issued on the 7-segment display in parallel. Status 6 indicates an error, status 7 an alarm. The explanation of the respective error codes can be found in the SafePLC2 manual.

***Note:**

In normal operation, the logic data is transmitted in byte 6 and byte 7. In the event of an error or alarm logic data is overwritten with the corresponding code until the alarm/error is cleared. Bit 7 of Byte 6 can be used to distinguish between the two modes.

Please take this into account when using the respective bits for visualization or process control.

The process data follow the logic data with a byte offset of 7; byte 0 of the process data is byte 8 of the total frame/input assignment.

Overview

Byte	Assignment
Byte 0	Status
Byte 1	Logic data (Bit ID: 48...55)
Byte 2	Logic data (Bit ID: 40...47)
Byte 3	Logic data (Bit ID: 32...39)
Byte 4	Logic data (Bit ID: 8...15)
Byte 5	Logic data (Bit ID: 0...7)
Byte 6	Logic data (Bit ID: 24...30) / Error code
Byte 7	Logic data (Bit ID: 16...23) / Error code
Byte 8	Process data (Bit: 56...63)
Byte 9	Process data (Bit: 48...55)
Byte 10	Process data (Bit: 40...47)
Byte 11	Process data (Bit: 32...39)
Byte 12	Process data (Bit: 24...31)
Byte 13	Process data (Bit 16...23)
Byte 14	Process data (Bit: 8...15)
Byte 15	Process data (Bit: 0...7)
Byte 16	not used
...	...
Byte 127	not used
Byte 128	SD-Gateway - Diagnostic
Byte 129	SD-Gateway - Data
Byte 130	SD-Slave 1 - Data
Byte 131	SD-Slave 1 - Diagnostic
Byte 132	SD-Slave 2 - Data
Byte 133	SD-Slave 2 - Diagnostic
...	...
Byte 190	SD-Slave 31 - Data
Byte 191	SD-Slave 31 - Diagnostic

Table 11: PSC1-C-10-x-FB1/2 logic and process data

9.1.2 Output data

Byte	Assignment
Byte 0	Logic data (Bit ID: 48...55)
Byte 1	Logic data (Bit ID: 48...55)
Byte 2	Logic data (Bit ID: 40...47)
Byte 3	Logic data (Bit ID: 32...39)
Byte 4	SD-Gateway - Instruction
Byte 5	SD-Gateway - Address
Byte 6	SD-Slave 1 - Request
Byte 7	SD-Slave 1 - Reserved
Byte 8	SD-Slave 2 - Request
Byte 9	SD-Slave 2 - Reserved
...	...
Byte 66	SD-Slave 31 - Request
Byte 67	SD-Slave 31 - Reserved

Table 12: PSC1-C-10-x-FB1/2 output data

9.2 PSC1-C-100-x-FB1/2

9.2.1 Input data

Three different profiles can be used; they are selected in SafePLC2.

9.2.1.1 Structure for device **profile 0** (= free assignment)

9.2.1.1.1 Profile 0 **with** axis extension modules (slave module)

Total size of diagnostic data: always 128 bytes

Byte offset	Description	Data size
0	Bit data type "1" (Logic data bit ID0 to bit ID55)	8 byte
8	Process data Slave module Addr. 1	12 byte
20	Bit data type "1" (Logic data bit ID56 to bit ID111)	8 byte
28	Process data Slave module Addr. 2	12 byte
40	Bit data type "1" (Logic data bit ID112 to bit ID167)	8 byte
48	Process data Slave module Addr. 3	12 byte
60	Bit data type "1" (Logic data bit ID168 to bit ID223)	8 byte
68	Process data Slave module Addr. 4	12 byte
80	Bit data type "1" (Logic data bit ID224 to bit ID279)	8 byte
88	Process data Slave module Addr. 5	12 byte
100	Bit data type "1" (Logic data bit ID280 to bit ID335)	8 byte
108	Process data Slave module Addr. 6	12 byte
120	Bit data type "1" (Logic data bit ID336 to bit ID391)	8 byte
128	SD-Gateway - Diagnostic	1 byte
129	SD-Gateway - Data	1 byte
130	SD-Slave 1 - Data	1 byte
131	SD-Slave 1 - Diagnostic	1 byte
132	SD-Slave 2 - Data	1 byte
133	SD-Slave 2 - Diagnostic	1 byte
...	...	1 byte
190	SD-Slave 31 - Data	1 byte
191	SD-Slave 31 - Diagnostic	1 byte

Table 13: Structure for device profile 0 (= free assignment) with extension modules

Offset for error number of the slave module: Offset bit data + 6

Please see 9.2.1.1.3 for explanation of data types

9.2.1.1.2 Profile 0 without axis extension modules (slave module)

Structure of the overall frame:

Total size of diagnostic data: always 128 bytes

Byte offset	Description	Data size
0	Bit data type "1" (Logic data bit ID0 to bit ID55)	8 byte
8	Bit data type "2" (Logic data bit ID56 to bit ID111)	7 byte
15	Bit data type "2" (Logic data bit ID112 to bit ID167)	7 byte
22	Bit data type "2" (Logic data bit ID168 to bit ID223)	7 byte
29	Bit data type "2" (Logic data bit ID224 to bit ID279)	7 byte
36	Bit data type "2" (Logic data bit ID280 to bit ID335)	7 byte
43 ...127	Not assigned	
128	SD-Gateway - Diagnostic	1 byte
129	SD-Gateway - Data	1 byte
130	SD-Slave 1 - Data	1 byte
131	SD-Slave 1 - Diagnostic	1 byte
132	SD-Slave 2 - Data	1 byte
133	SD-Slave 2 - Diagnostic	1 byte
...	...	1 byte
190	SD-Slave 31 - Data	1 byte
191	SD-Slave 31 - Diagnostic	1 byte

Table 14: Structure for device profile 0 (= free assignment) without extension modules

Offset for error number of the master module: Offset bit data + 6 (only in bit data type "1")

Please see 9.2.1.1.3 for explanation of data types

9.2.1.1.3 Profile 0 - Data types

- Bit data type "1"

Byte	Bit	"Run" mode (2, 3, 4)	Error case (A, F)
Byte 0	0..3	PSC1 mode 1, 2, 3, 4, 5, 6 = Fatal error, 7 = Alarm	
	4	1	
	5..7	Alive counter (3 Bit)	
Byte 1	0..7	Logic data (Bit ID: 48..55)	
Byte 2	0..7	Logic data (Bit ID: 40..47)	
Byte 3	0..7	Logic data (Bit ID: 32..39)	
Byte 4	0..7	Logic data (Bit ID: 8..15)	
Byte 5	0..7	Logic data (Bit ID: 0..7)	
Byte 6*	0.6	Logic data (Bit ID:24.. 30)	Error code: high Byte
	7	0	1
Byte 7*	0..7	Logic data (Bit ID: 16..23)	Error code: low Byte

Table 15: Bit data type "1"

The bits 'PSC1 mode' show the status of the control. The states 1-5 are issued on the 7-segment display in parallel. Status 6 indicates an error, status 7 an alarm. The explanation of the respective error codes can be found in the SafePLC2 manual

***Note:**

In normal operation, the logic data is transmitted in byte 6 and byte 7. In the event of an error or alarm logic data is overwritten with the corresponding code until the alarm/error is cleared. Bit 7 of Byte 6 can be used to distinguish between the two modes.

Please take this into account when using the respective bits for visualization or process control.

- Bit data type "2"

Byte	Bit	Assignment
Byte 0	0..7	Logic data (Bit: 48..55)
Byte 1	0..7	Logic data (Bit: 40..47)
Byte 2	0..7	Logic data (Bit: 32..39)
Byte 3	0..7	Logic data (Bit: 8..15)
Byte 4	0..7	Logic data (Bit: 0..7)
Byte 5	0.6	Logic data (Bit:24.. 30)
	7	0
Byte 6	0..7	Logic data (Bit: 16..23)

Table 16: Bit data type "2"

- Process data

Byte	Data
Byte 0	Process data bit 0..7
Byte 1	Process data bit 8..15
Byte 2	Process data bit 16..23
Byte 3	Process data bit 24..31
Byte 4	Process data bit 32..39
Byte 5	Process data bit 40..47
Byte 6	Process data bit 48..55
Byte 7	Process data bit 56..63
Byte 8	Process data bit 64..71
Byte 9	Process data bit 72..79
Byte 10	Process data bit 80..87
Byte 11	Process data bit 88..95

Table 17: Process data

9.2.1.2 Structure for device **profile 1** (= only logic data)

Byte	Bit	"Run" mode (2, 3, 4)	Error case (A, F)
Byte 0	0..3	PSC1 mode 1, 2, 3, 4, 5, 6 = Fatal error, 7 = Alarm	
	4	1	
	5..7	Alive counter (3 Bit)	
Byte 1	0..7	0	Device address at which an error occurred
Byte 2	0..7	Reserved	
Byte 3	0..7	0	Error code high byte
Byte 4	0..7	0	Error code: low byte
Byte 5	0..7	Logic data (Bit ID: 0..7)	
Byte 6	0..7	Logic data (Bit ID: 8..15)	
Byte 7	0..7	Logic data (Bit ID: 16..23)	
Byte 8	0..7	Logic data (Bit ID: 24..30)	
Byte 9	0..7	Logic data (Bit ID: 32...39)	
Byte 10	0..7	Logic data (Bit ID: 40..47)	
...	
Byte 55	0..7	Logic data (Bit ID: 400..407)	
...	...	Not used	
Byte 128	0..7	SD-Gateway - Diagnostic	
Byte 129	0..7	SD-Gateway - Data	
Byte 130	0..7	SD-Slave 1 - Data	
Byte 131	0..7	SD-Slave 1 - Diagnostic	
Byte 132	0..7	SD-Slave 2 - Data	
Byte 133	0..7	SD-Slave 2 - Diagnostic	
...	
Byte 190	0..7	SD-Slave 31 - Data	
Byte 191	0..7	SD-Slave 31 - Diagnostic	

Table 18: Structure for device profile 1 (= only logic data)

The bits 'PSC1 mode' show the status of the control. The states 1-5 are issued on the 7-segment display in parallel. Status 6 indicates an error, status 7 an alarm.

Note:

The meaning of the error codes in decimal notation can be found in the programming manual.

The following logic data bit IDs are reserved for compatibility reasons and cannot be used (value always 0):

- Bit ID 31
- Bit ID 87
- Bit ID 143
- Bit ID 199
- Bit ID 255
- Bit ID 311
- Bit ID 367

9.2.1.3 Structure for device **profile 2** (= logic data + process data for each slave)

Byte	Bit	"Run" mode (2, 3, 4)	Error case (A, F)
Byte 0	0..3	PSC1 mode 1, 2, 3, 4, 5, 6 = Fatal error, 7 = Alarm	
	4	1	
	5..7	Alive counter (3 Bit)	
Byte 1	0..7	0	Device address at which an error occurred
Byte 2	0..7	Reserved	
Byte 3	0..7	0	Error code: low byte
Byte 4	0..7	0	Error code high byte
Byte 5	0..7	Logic data (Bit ID: 0..7)	
Byte 6	0..7	Logic data (Bit ID: 8..15)	
Byte 7	0..7	Logic data (Bit ID: 16..23)	
Byte 8	0..6	Logic data (Bit ID: 24..30)	
	7	0	
Byte 9	0..7	Logic data (Bit ID: 32...39)	
Byte 10	0..7	Logic data (Bit ID: 40..47)	
...	
Byte 55	0..7	Logic data (Bit ID: 400..407)	
Byte 56	0..7	Process data axis modules slave 1 bit 0..7	
Byte 57	0..7	Process data axis modules slave 1 bit 8..15	
Byte 58	0..7	Process data axis modules slave 1 bit 16..23	
Byte 59	0..7	Process data axis modules slave 1 bit 24..31	
Byte 60	0..7	Process data axis modules slave 1 bit 32..39	
Byte 61	0..7	Process data axis modules slave 1 bit 40..47	
Byte 62	0..7	Process data axis modules slave 1 bit 48..55	
Byte 63	0..7	Process data axis modules slave 1 bit 56..63	
Byte 64	0..7	Process data axis modules slave 1 bit 64..71	
Byte 65	0..7	Process data axis modules slave 1 bit 72..79	
Byte 66	0..7	Process data axis modules slave 1 bit 80..87	
Byte 67	0..7	Process data axis modules slave 1 bit 88..95	
Byte 68	0..7	Process data axis modules slave 2 bit 0..7	
...	
Byte 79	0..7	Process data axis modules slave 2 bit 88..95	
Byte 80	0..7	Process data axis modules slave 3 bit 0..7	
...	
Byte 91	0..7	Process data axis modules slave 3 bit 88..95	
Byte 92	0..7	Process data axis modules slave 4 bit 0..7	
...	
Byte 103	0..7	Process data axis modules slave 4 bit 88..95	

Byte 104	0..7	Process data axis modules slave 5 bit 0..7
...
Byte 115	0..7	Process data axis modules slave 5 bit 88..95
Byte 116	0..7	Process data axis modules slave 6 bit 0..7
...
Byte 127	0..7	Process data axis modules slave 6 bit 88..95
Byte 128	0..7	SD-Gateway - Diagnostic
Byte 129	0..7	SD-Gateway - Data
Byte 130	0..7	SD-Slave 1 - Data
Byte 131	0..7	SD-Slave 1 - Diagnostic
Byte 132	0..7	SD-Slave 2 - Data
Byte 133	0..7	SD-Slave 2 - Diagnostic
...
Byte 190	0..7	SD-Slave 31 - Data
Byte 191	0..7	SD-Slave 31 - Diagnostic

Table 19: Structure for device profile 1 (= logic data + process data for each slave)

The bits 'PSC1 mode' show the status of the control. The states 1-5 are issued on the 7-segment display in parallel. Status 6 indicates an error, status 7 an alarm.

Note:

The meaning of the error codes in decimal notation can be found in the programming manual.

The following logic data bit IDs are reserved for compatibility reasons and cannot be used (value always 0):

- Bit ID 31
- Bit ID 87
- Bit ID 143
- Bit ID 199
- Bit ID 255
- Bit ID 311
- Bit ID 367

9.2.2 Output data

Byte	Assignment
Byte 0	Logic data (Bit ID: 48..55)
Byte 1	Logic data (Bit ID: 48..55)
Byte 2	Logic data (Bit ID: 40..47)
Byte 3	Logic data (Bit ID: 32..39)
Byte 4	SD-Gateway - Instruction
Byte 5	SD-Gateway - Address
Byte 6	SD-Slave 1 - Request
Byte 7	SD-Slave 1 - Reserved
Byte 8	SD-Slave 2 - Request
Byte 9	SD-Slave 2 - Reserved
...	...
Byte 66	SD-Slave 31 - Request
Byte 67	SD-Slave 31 - Reserved

Table 20: PSC1-C-100-FB1/2 output data

9.3 SD-Bus data

The universal communication interface (option -FB1/2) behaves like a gateway with regard to the SD bus data; communication from the SD bus to the fieldbus in both directions.

9.3.1 Fieldbus data SD-Bus Gateway

For the Gateway diagnostics and for the acyclic data request of the SD slaves, 2 bytes are reserved in the request and the response of the fieldbus protocol.

Request:	Byte 00	instruction byte, acyclic data request
	Byte 01	SD slave address for the acyclic data request
Response:	Byte 00	diagnostic byte Gateway (refer to table 19)
	Byte 01	data byte, acyclic data request

The detailed description of the acyclic data request of SD slaves can be found in chapter 9.3.4.

9.3.2 Fieldbus data SD slave

For each SD slave, 2 bytes are reserved in the request and the response of the fieldbus protocol.

- SD slave 01 uses byte 02 and 03 of the fieldbus
- SD slave 02 uses byte 04 and byte 05 of the fieldbus
- ... etc.
- SD slave 31 uses byte 62 and byte 63 of the fieldbus

In the **request**, only the first byte is needed in the fieldbus as request byte for an SD slave. The second byte is not used.

In the **response**, first the response byte and subsequently the diagnostic byte of each SD slave is transmitted to the fieldbus.

9.3.3 Structure of the SD bytes in the fieldbus protocol

Request for all fieldbus systems (OUTPUT byte control, transmission of the request data to the SD slave)

Byte no.	Byte 00	Byte 01	Byte 02	Byte 03	...	Byte 62	Byte 63
SD device	Gateway	Gateway	Slave 01	Slave 01	...	Slave 31	Slave 31
Content	Instruction byte	SD-Addr. (0, 1-31)	Request byte	---		Request byte	---

Response for all fieldbus systems (INPUT byte control, reception of the response data of the SD slave)

Byte no.	Byte 00	Byte 01	Byte 02	Byte 03	...	Byte 62	Byte 63
SD device	Gateway	Gateway	Slave 01	Slave 01	...	Slave 31	Slave 31
Content	Diagnostic byte	Date byte	Response byte	Diagnostic byte		Response byte	Diagnostic byte

The content of the diagnostic byte of an SD slave depends on the status of the warning and the error bits in the corresponding response byte (Bit 6 = error warning and Bit 7 = error).

The meaning of the individual bits of the SD bytes is explained in the mounting instructions of the SD devices

9.3.4 Reading acyclic data from the SD slave

In a permanently defined cycle, acyclic data of the individual SD slave can be requested through the 2 request bytes (fieldbus request byte 00 and byte 01) and the data byte (fieldbus response byte 01).

The instruction byte defines, which data will be requested from a slave. The SD device, from which the data are requested, is defined in the SD interface by means of the SD address byte. The response data of the SD slaves are saved in the fieldbus response byte 01.

The data request cycle is defined as follows:

1. The control deletes the data byte before or after each command. A feedback signal is generated through the response byte, indicating whether the data have been deleted or not.
Hex FF: Data deleted, acyclic data service ready
2. The control first writes the SD address into the fieldbus request byte 01.
Then, the control writes the instruction byte into the fieldbus request byte 00
3. The response data are made available in the fieldbus response byte 01 of the control.
The data byte can also include an error message as response:
Hex FE: Instruction error, undefined instruction requested
Hex FD: Address error, invalid slave address for the selected instruction
or slave address of a unavailable SD slave selected

Instructions, acyclic data request	Instruction byte fieldbus byte 00 (request)	SD address fieldbus byte 01 (request)	Data byte fieldbus byte 01 (response)	Data description
Delete data byte	Hex: 00	Hex: xx	Hex: FF	Data deleted, ready for new instruction
Read number of projected SD slaves	Hex: 01	Hex: 00	Hex: 01 to Hex: 1F	Number of projected SD slaves 1 – 31
Read device category of the SD slave	Hex: 02	Hex: 01 to Hex: 1F	Hex: 30 to Hex: F8	SD slave device category (see below)
Read hardware revision of the SD slave	Hex: 03	Hex: 01 to Hex: 1F	Hex: 41 to Hex: 5A	Hardware revision A –Z as ASCII characters
Read software version of the SD slave (high byte)	Hex: 04	Hex: 01 to Hex: 1F	Hex: 00 to Hex: 63	Software version, high byte: 0-99
Read software version of the SD slave (low byte)	Hex: 05	Hex: 01 to Hex: 1F	Hex: 00 to Hex: 63	Software-Version, Low-Byte: 0 - 99

Table 21: Overview of the instructions and response data

The device category of a SD slave can be found in the mounting instructions of the device concerned.

The following device categories are defined:

- Hex: 30 CSS 34, Safety sensor
- Hex: 31 AZM 200, Solenoid interlock „Z“-variant
- Hex: 32 MZM 100, Solenoid interlock „Z“-variant
- Hex: 33 AZ 200, Safety sensor
- Hex: 34 CSS 30S, Safety sensor
- Hex: 35 MZM 100 B, Solenoid interlock „B“-variant
- Hex: 36 AZM 300B, Solenoid interlock „B“-variant
- Hex: 37 RSS 36, Safety sensor
- Hex: 38 AZM 300Z, Solenoid interlock „Z“-variant
- Hex: 39 RSS 16, Safety sensor
- Hex: 3A RSS 260, Safety sensor
- Hex: 3D MZM 120 B, Solenoid interlock „B“-variant
- Hex: 3E MZM 120 BM, Solenoid interlock „B“-variant
- Hex: 3F AZM 201Z, Solenoid interlock „Z“-variant
- Hex: 40 AZM 201B, Solenoid interlock „B“-variant
- Hex: 41 Operator panel BDF200-SD
- Hex: 43 AZ 201, Safety sensor

The individual bits in the diagnostic byte for the SD-Gateway have the following meaning:

BIT	Error	Description
Bit 0	Failure SD-Interface	SD Interface centralized alarm, message 1 sec. delayed, invalid SD data.
Bit 1	–	
Bit 2	–	
Bit 3	–	
Bit 4	SD initialisation error	Reinitialization of the SD chain required! Shut down operating voltage of the gateway and SD Slaves. Possibly no SD slave connected!
Bit 5	SD Teach error	SD chain structure has changed.
Bit 6	SD short circuit	Short-circuit on the SD interface wires. Switch off and eliminate error.
Bit 7	SD communication error	One or more SD slaves unavailable. Invalid data from the SD slaves. Check SD installation.

Table 22: SD Master Diagnose, SD System error / Content Response byte 00, Diagnostic byte Gateway

10 Assigning IP address (-FB1 option only)

On delivery, the fieldbus Profinet is activated for devices with the -FB1 option. An IP address can be assigned to such a device via the IP Administrator tool.

When using the Ethernet/IP interface, please refer to

Chapter 12: Commissioning and configuration EtherNet/IP in SafePLC2 and RSLogix500

Start the tool via the IP-Administrator button in the Connection tab.

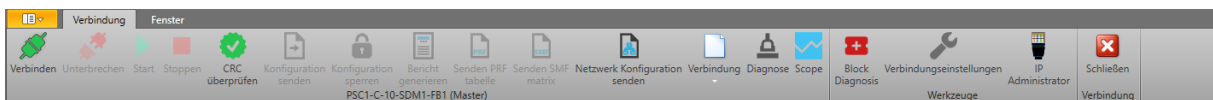

Figure 9: executing IP-Administrator via the connection tab

At startup, the system checks whether a WinPcap driver is installed on the computer. WinPcap is also used by tools such as Wireshark and is used to receive IP packets for network analysis. If WinPcap is not installed, this driver can be downloaded from the website www.winpcap.org.

Note:

The compatibility mode of Npcap (<https://nmap.org/npcap/>) must not be used. However, a parallel installation can exist.

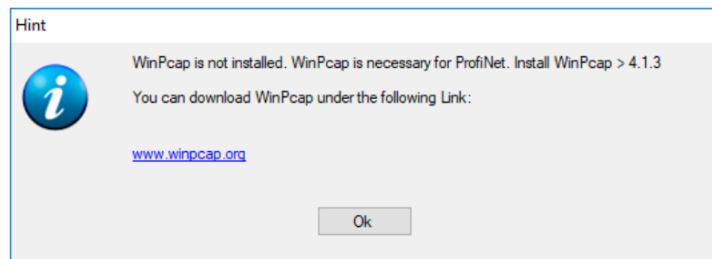

Figure 10: missing WinPcap driver message

First select the network card which is connected to the respective PSC1.

Note: Only network cards are listed that are connected to an active network. The IP address of the selected network card must be in the same IP address range (subnet mask) as the PSC1.

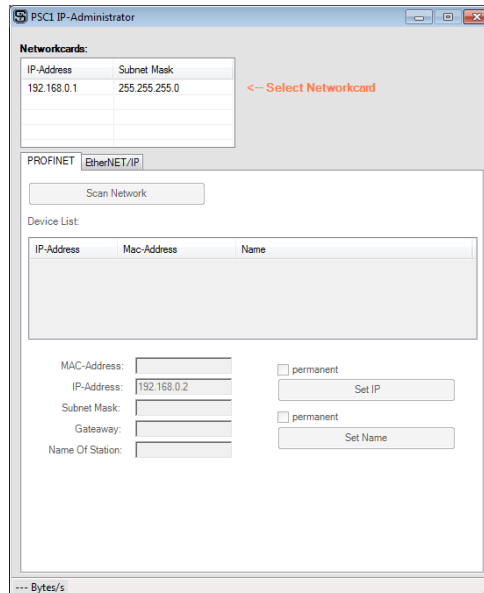

Figure 11: Select network card

The *Scan Network* button runs the search. All devices found will be listed in the *Device list*

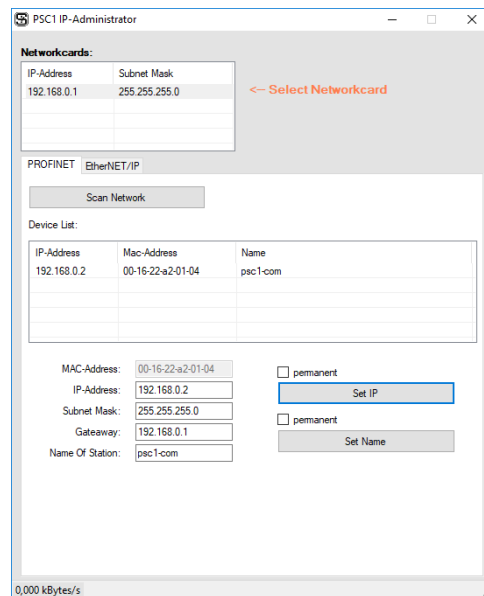

Figure 12: List of found devices

In this list the parameters for IP-Address and/or Name of Station can be modified here for the selected device. Changes were taken over by pressing the respective buttons *Set IP* and *Set Name*.

Note: The MAC-Address printed on the devices represents the MAC-Address of the SDDC connection ports. The MAC-Address of the fieldbus ports is derived following the example:

00:16:22:22:12:34

00:16:22:A2:12:34

& 80h

11 Commissioning and configuration PROFINET in SafePLC2 and TIA Portal (from Step 7 V10)

PROFINET is available for all PSC1 base devices with the "-FB1" option. The "-FB1" option is always permanently integrated in the base device and represents the gateway from the CAN-based backplane bus of the PSC1 series to PROFINET. It enables the user to exchange data bidirectionally via PROFINET with a higher-level controller.

In the properties of the PSC1 base device, the:

- **Local Network** - the property **fieldbus** is activated,

and in the **fieldbus properties (Fieldbus PROFINET)** under:

- **TYPE - PROFINET**

as well as under

- **Network Patterns (network prototype) - non-safe** for non-safe data transmission

must be selected.

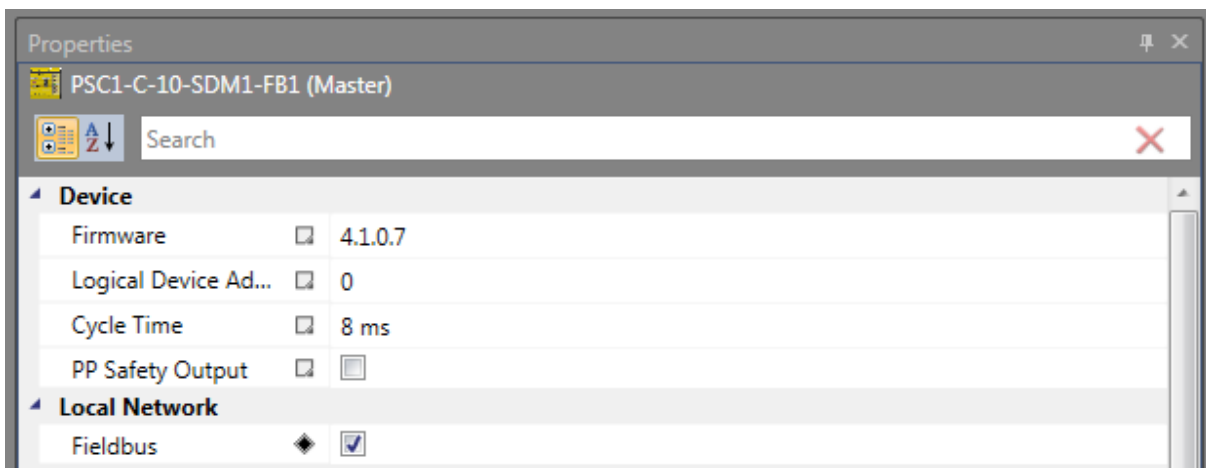

Figure 13: Properties PSC1 basic device - PROFINET

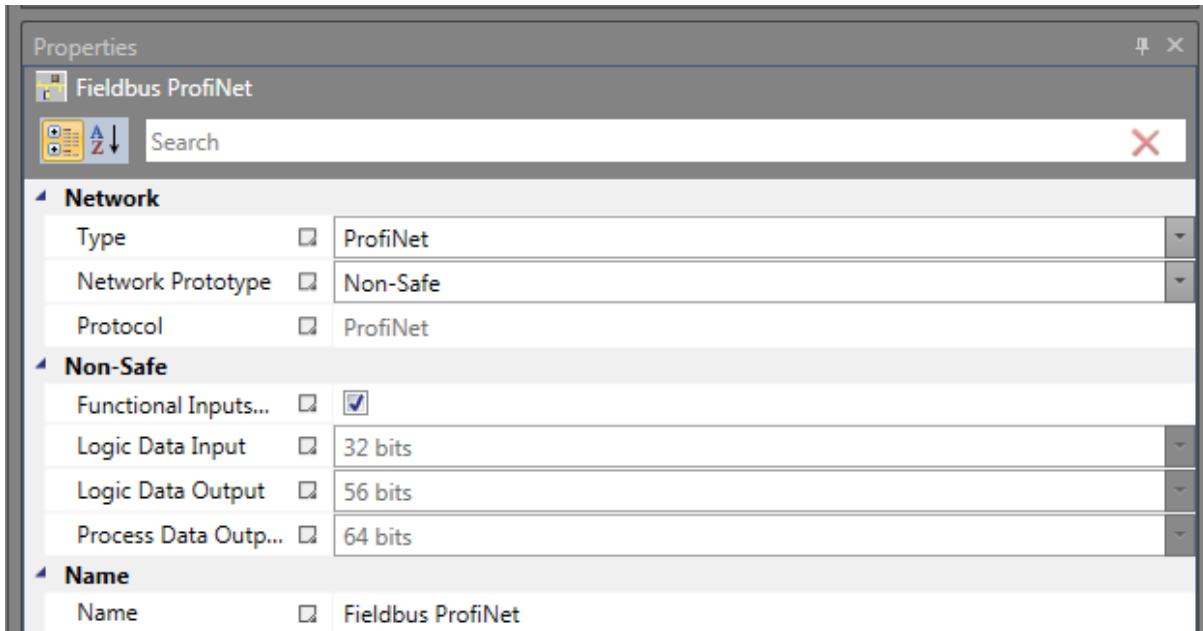

Figure 14: Properties fieldbus (Fieldbus PROFINET) - non-safe

Parametrisation for safe data transmission (PROFIsafe)

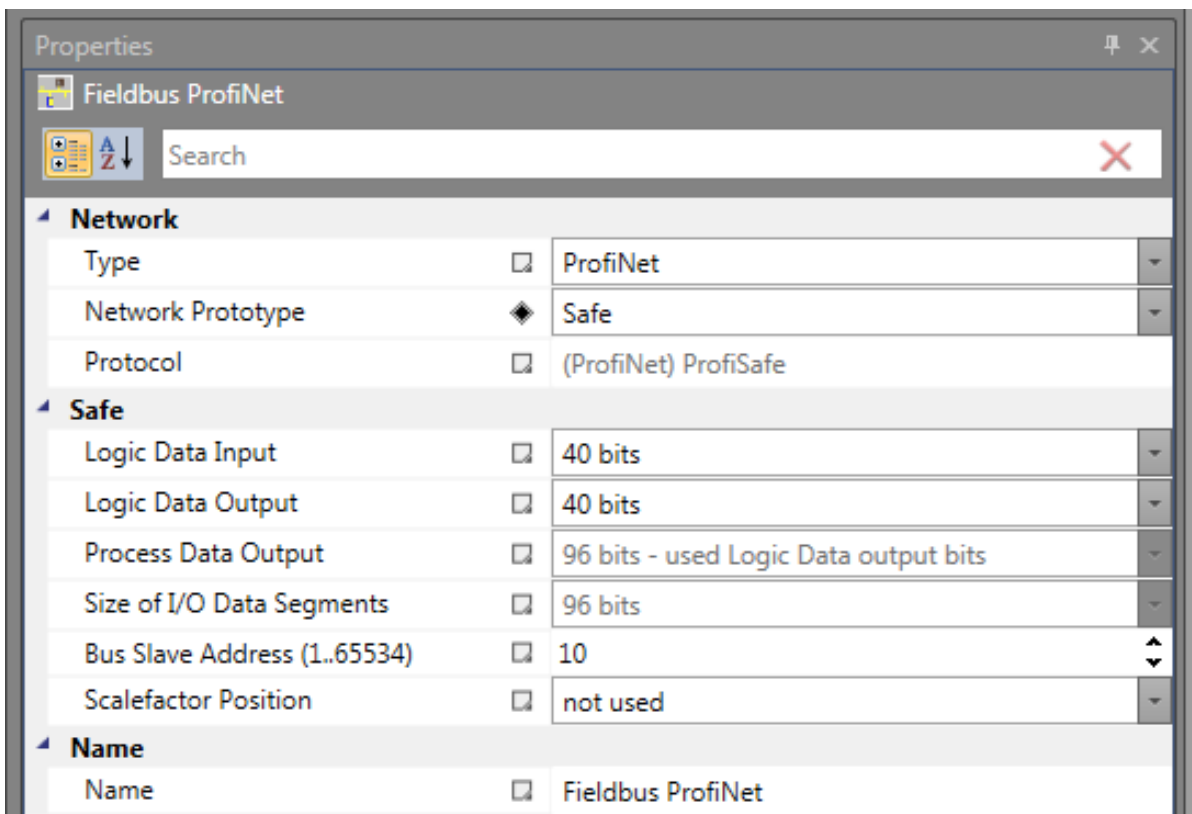

Figure 15: Properties fieldbus (Fieldbus PROFINET) - safe

Parametrisation for non-safe and safe data transmission (PROFIsafe)

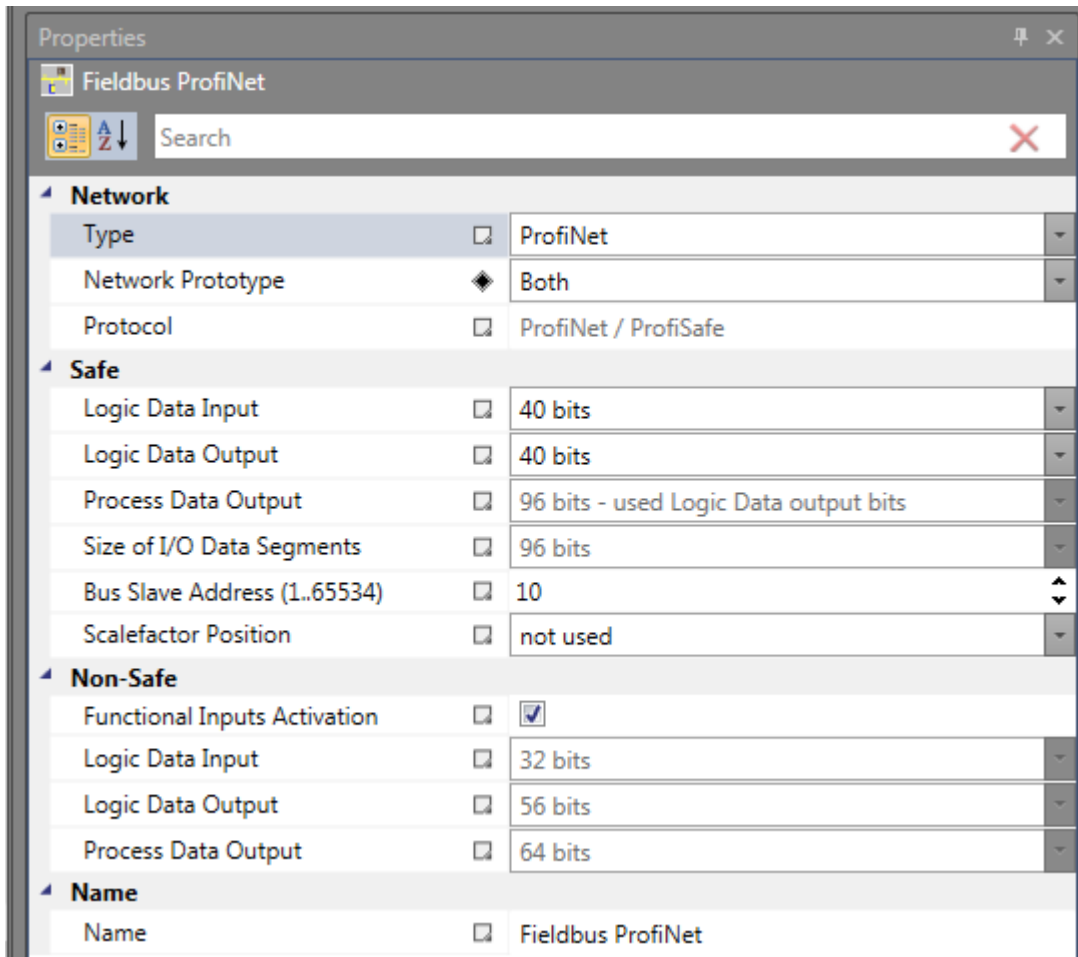
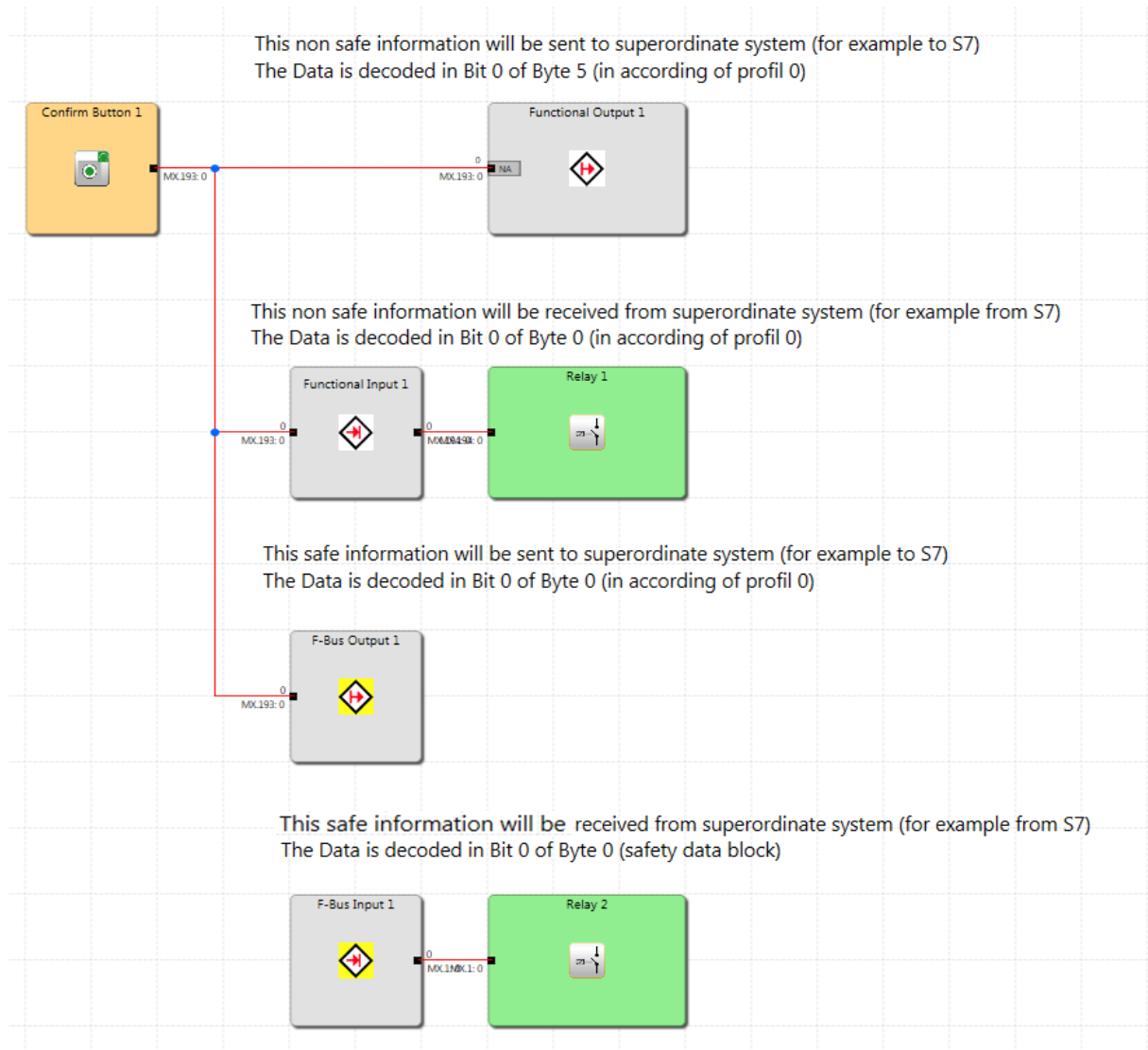

Figure 16: Properties fieldbus (Fieldbus PROFINET) - both

The functional inputs and outputs must still be inserted in the "Functional scheme" and logically connected.



The project and the network configuration must be transferred:
"Click the "Device Interface" icon



Click the "Connect" icon in the new dialogue.

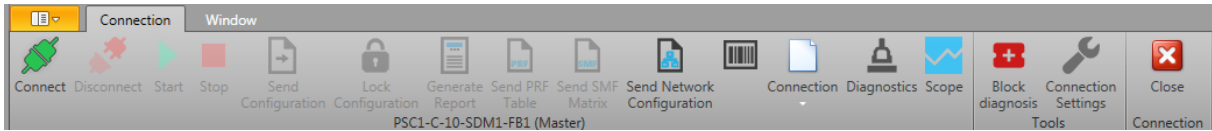

The successful connection to PSC1 is displayed in the following dialogue ("Connect icon" faded out / "Disconnect icon" faded in).

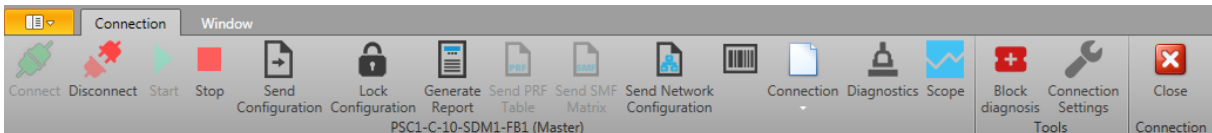

Now the network configuration and the source code can be transferred.

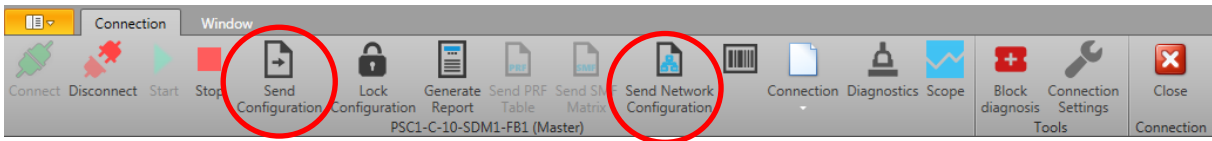

The transfer status (progress bar) is displayed in the lower information bar.

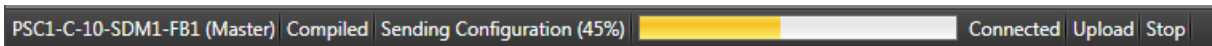

After transmission, the PSC1 may have to be restarted ("Green arrow icon").

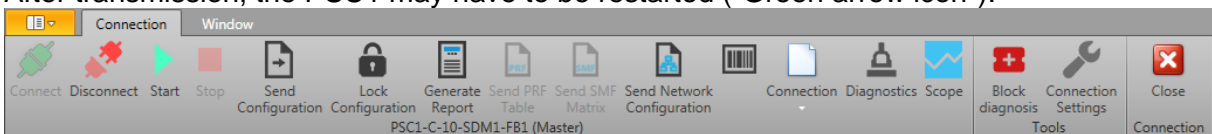

11.1 Parameter configuration

The parameters are set using the "TIA Portal" program from Siemens AG.

11.1.1 Installing the XML file

Click on "Tools" => "Manage device description files (GSD)".

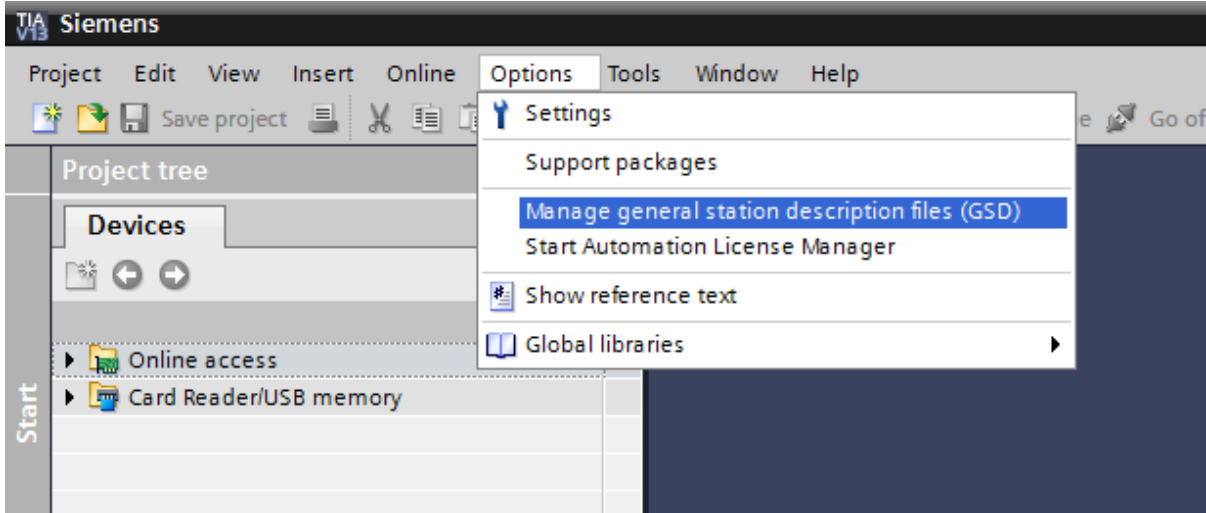

Select "Source path" and confirm the selection with "Install".

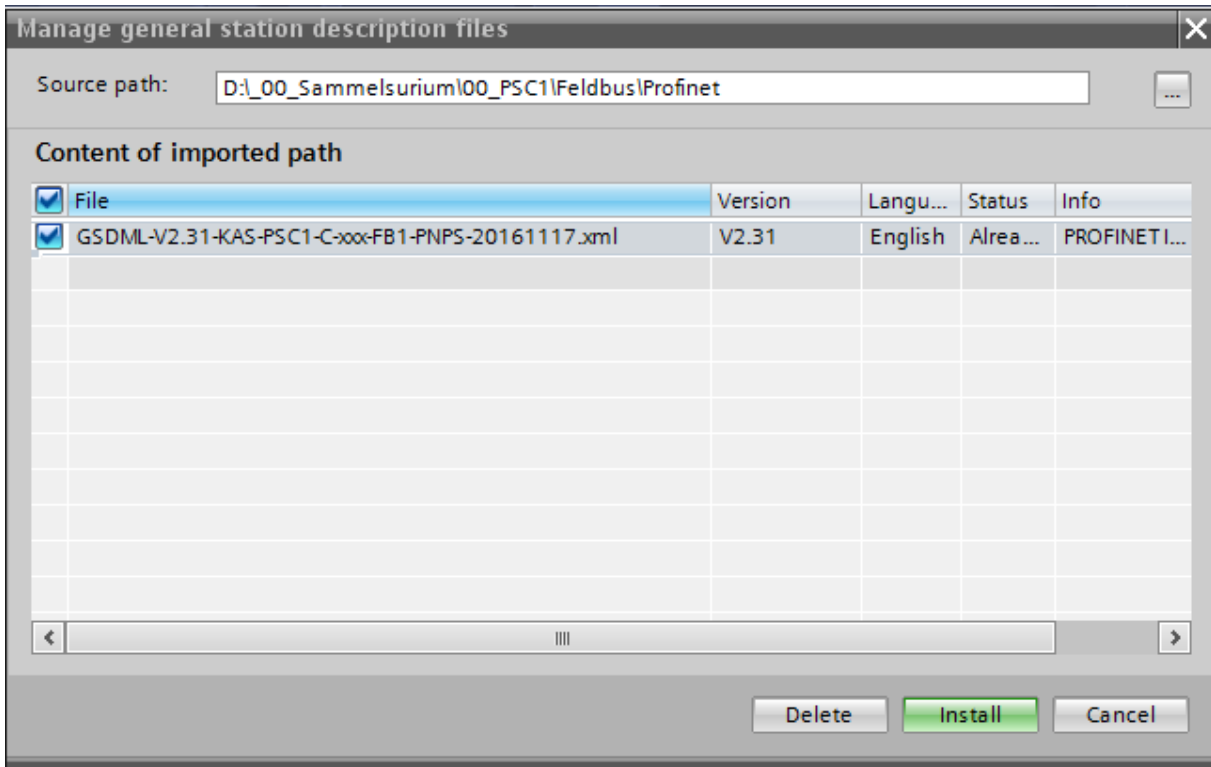

The device catalogue is updated.

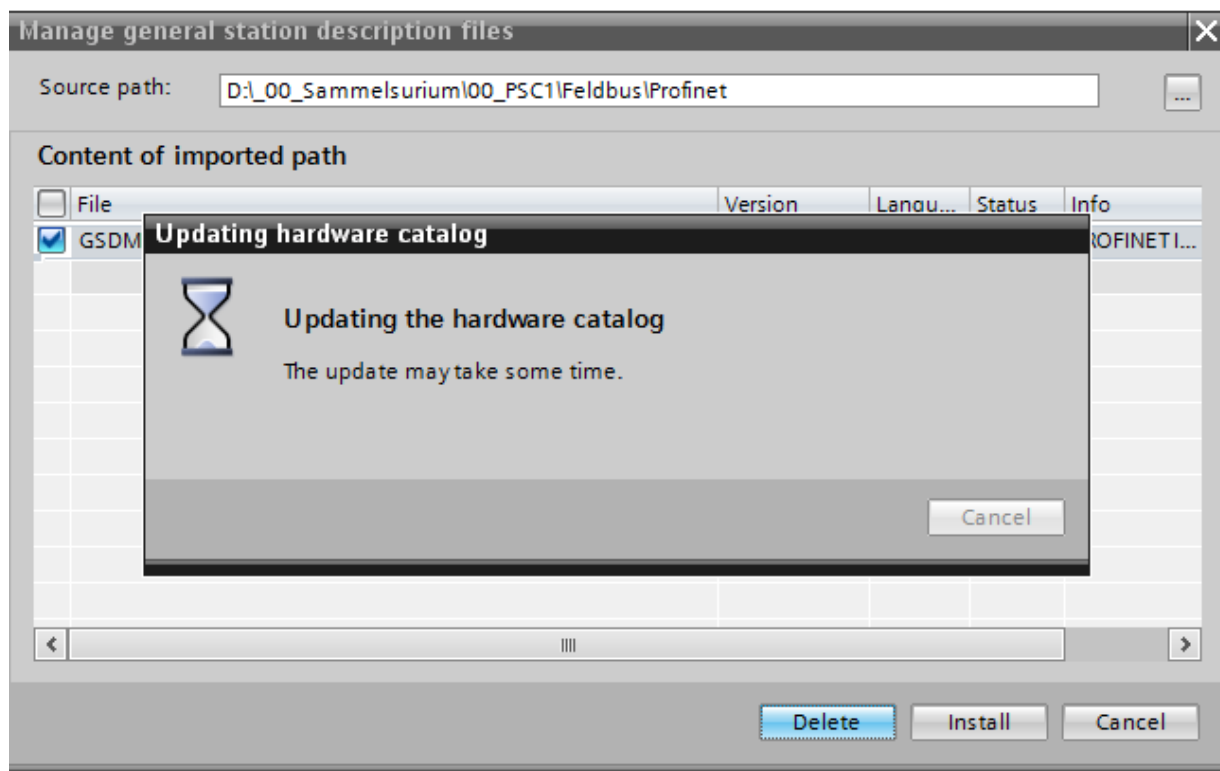

The installation result of the XML file is displayed.

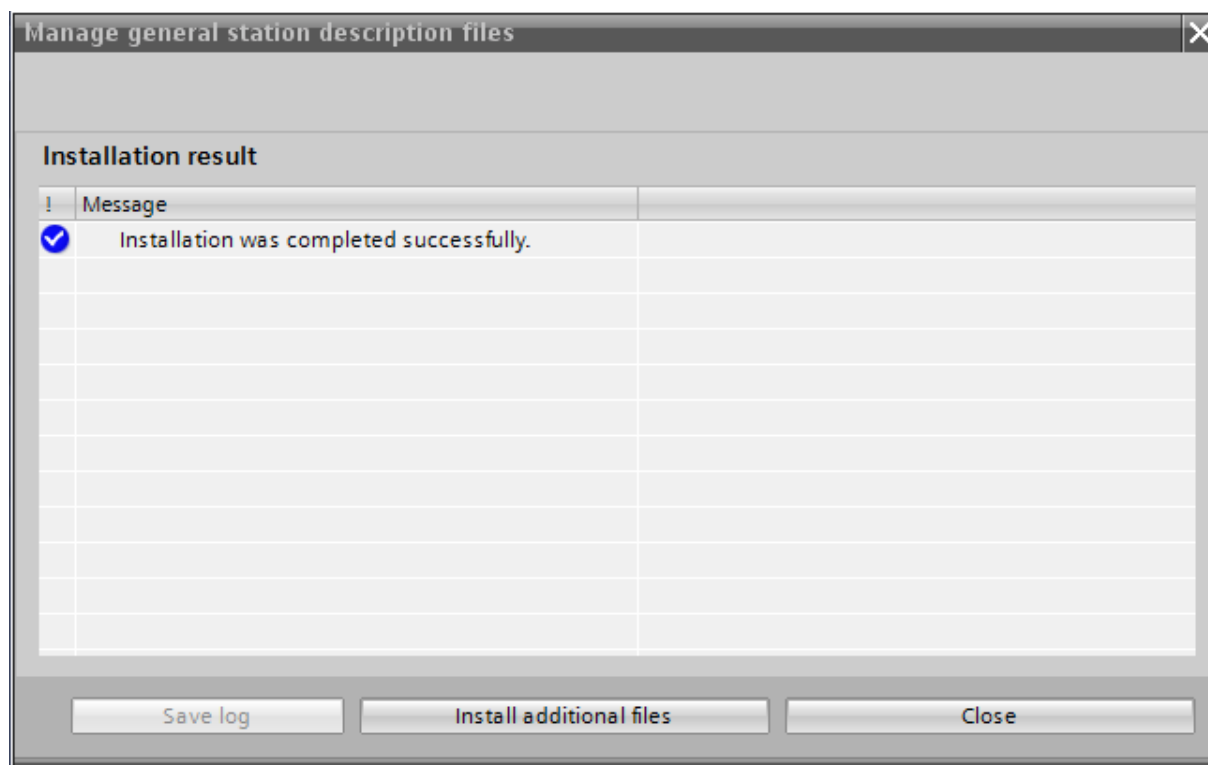

11.1.2 Create project and insert PSC1 with PROFINET

Create a new project with "Project" => "New".

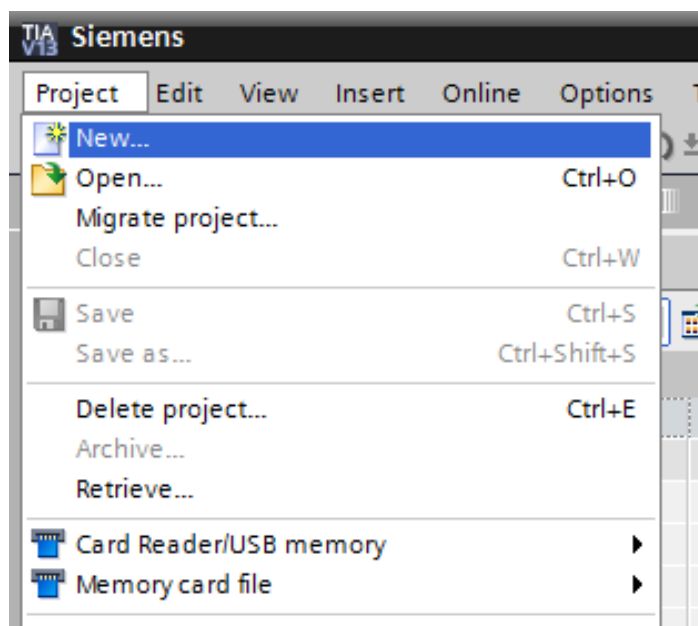

Assign a project name.

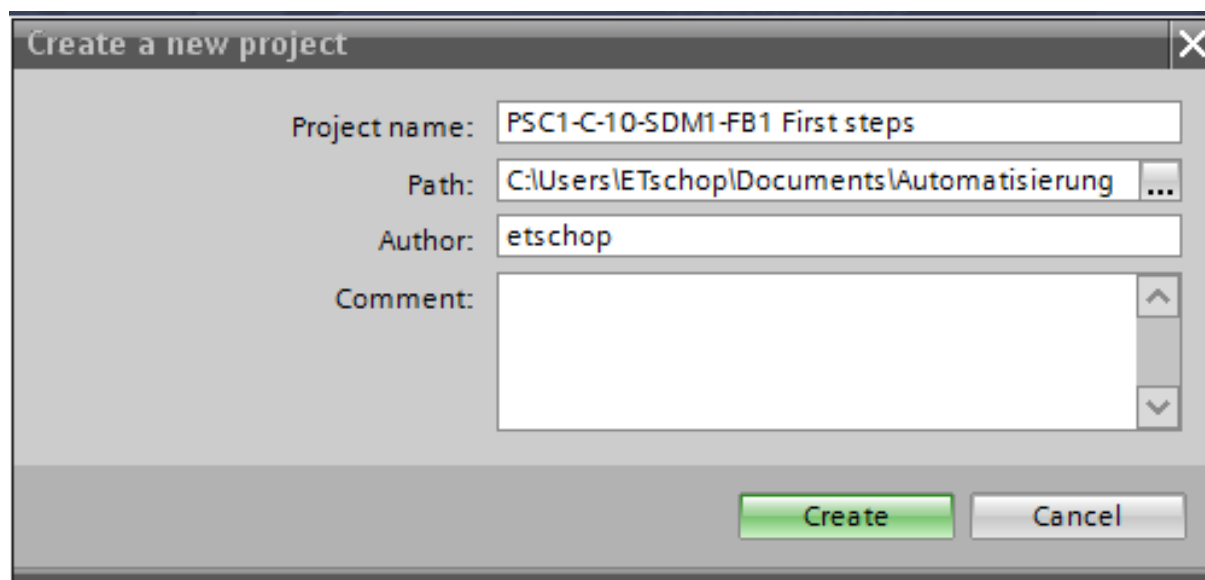

Call up the hardware catalogue in the "Network overview".

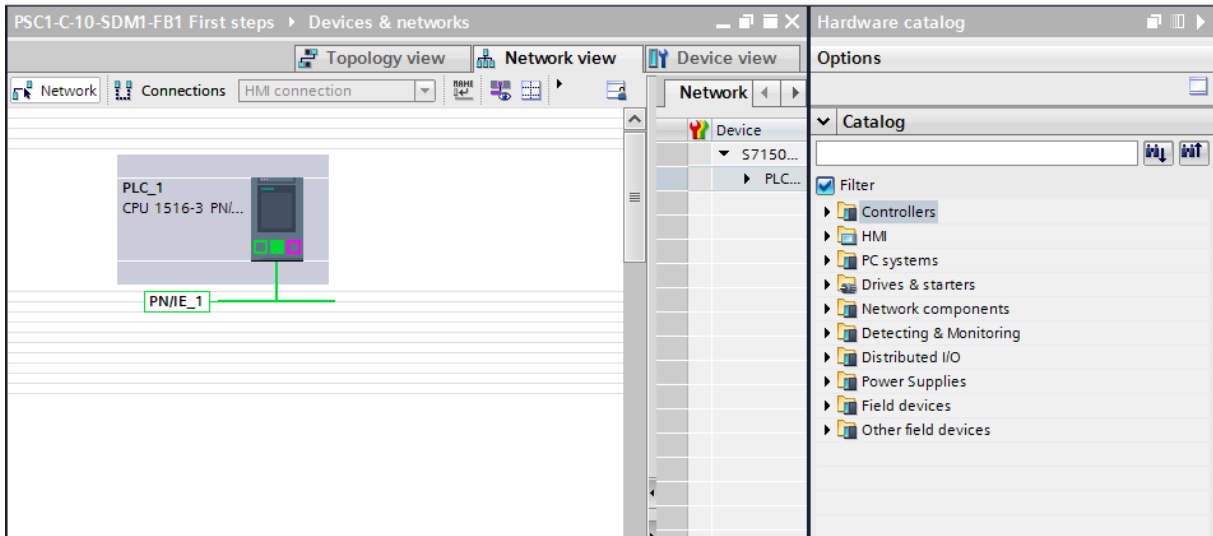

Enter "PSC1" in the search field of the hardware catalogue and confirm with "Enter".

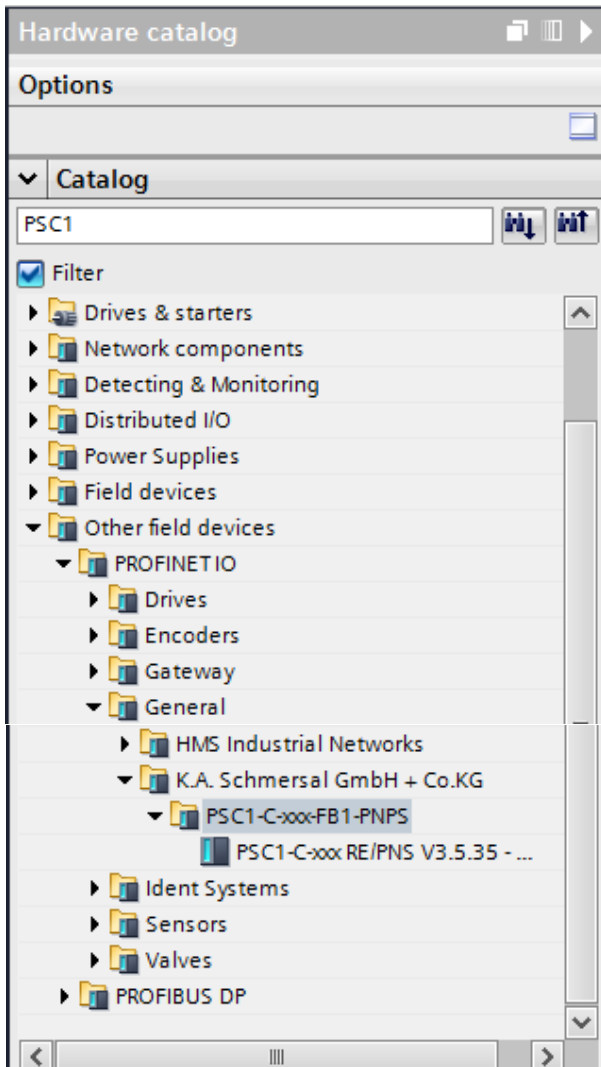

Confirm the selection by double-clicking.

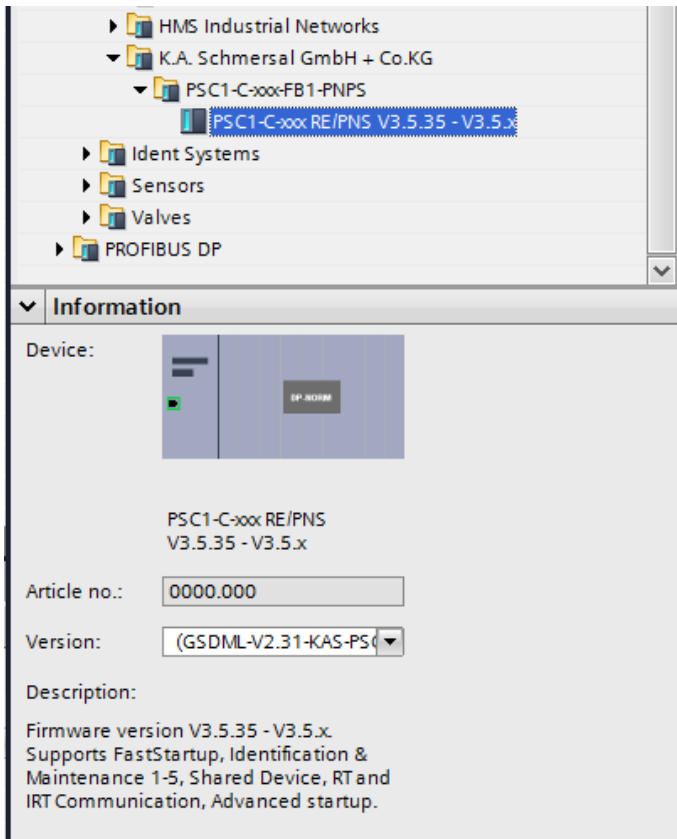

The inserted device is displayed in the "Network Overview".

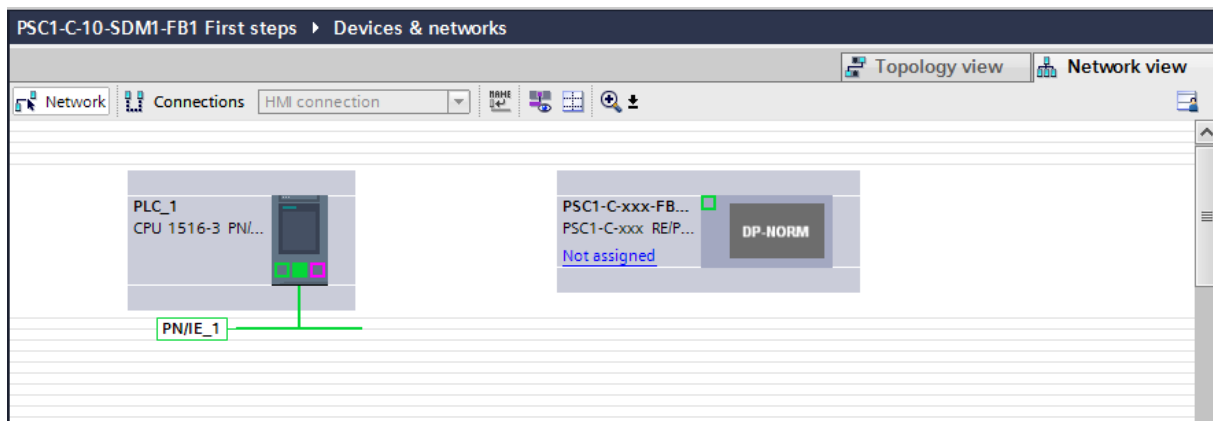

The PSC1-C-xxx-FB must still be assigned. Click on "not assigned" and select the master control.

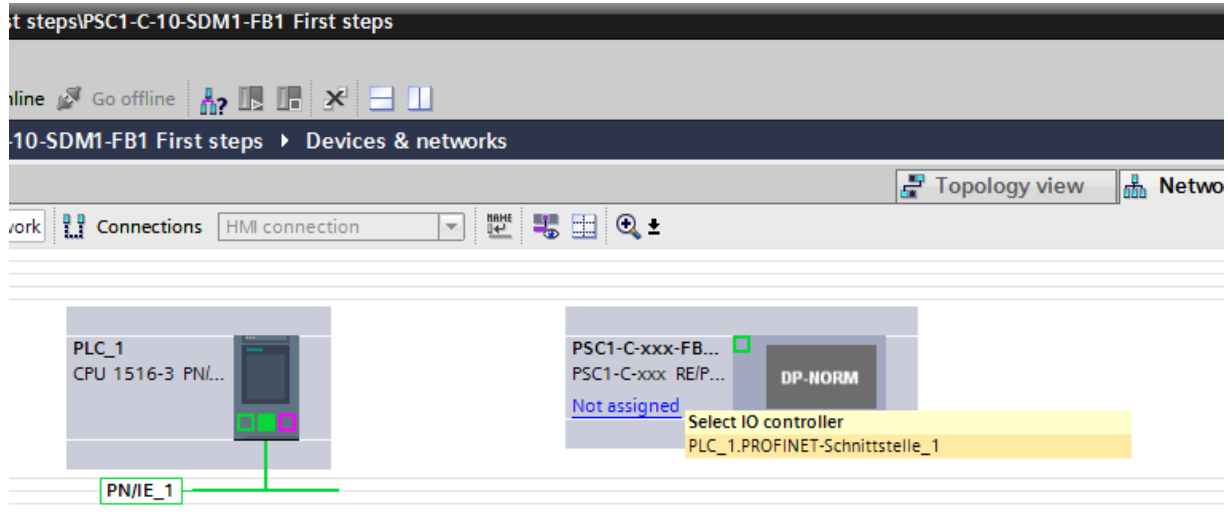

The successful assignment is indicated by a connection line.

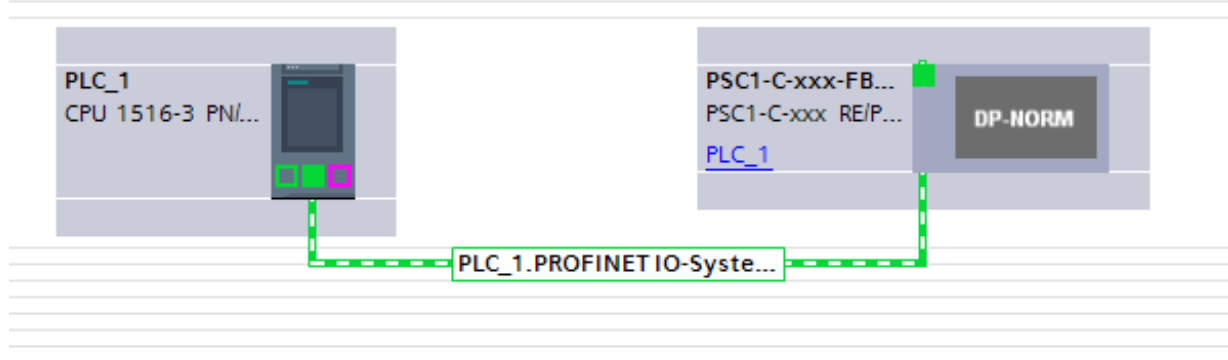

Double-click on PSC1-C-xxx-FB... to access the "Device overview".

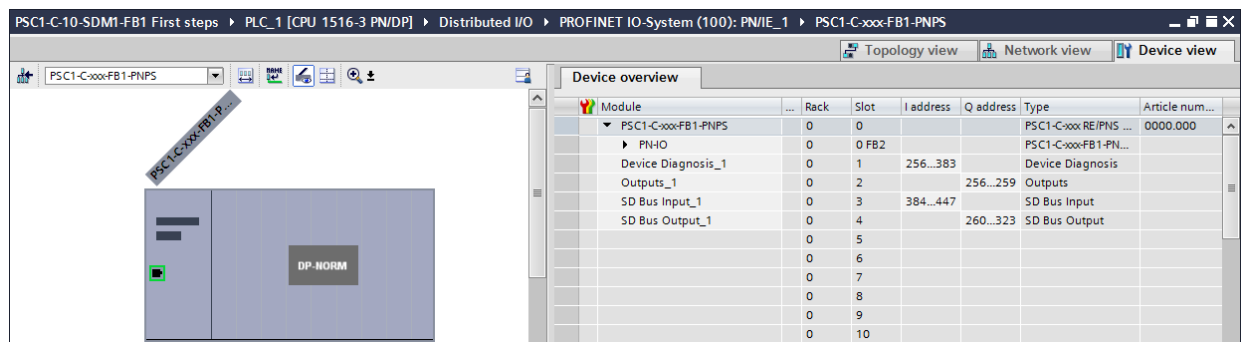

11.1.3 Setting up safe data transmission

If you do not want to set up safe data transfer, proceed with "11.1.4 Setting up an online connection".

A safe communication module "F modules" from the device catalogue must be inserted in the device overview.

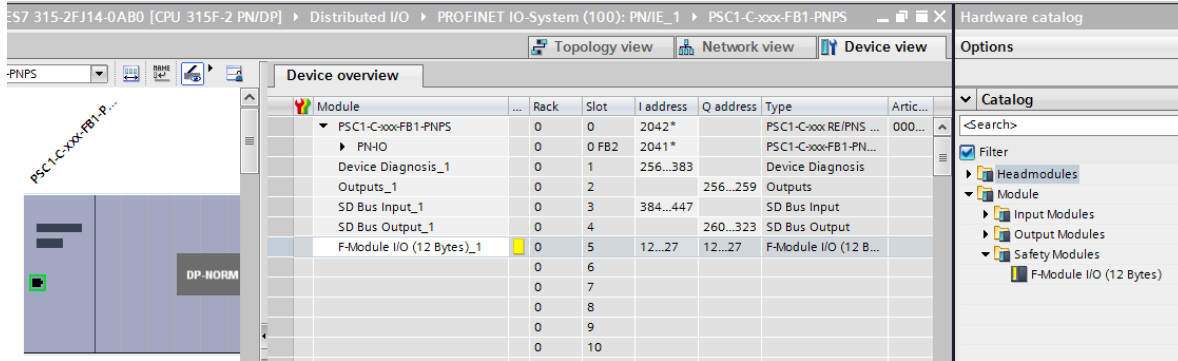

Click on the safe communication module to access the properties of the security module. The "PROFIsafe" tab must be used to adjust the target address and the monitoring time.

The destination address must correspond to the address preset in SafePLC2 (in the example the address 10)

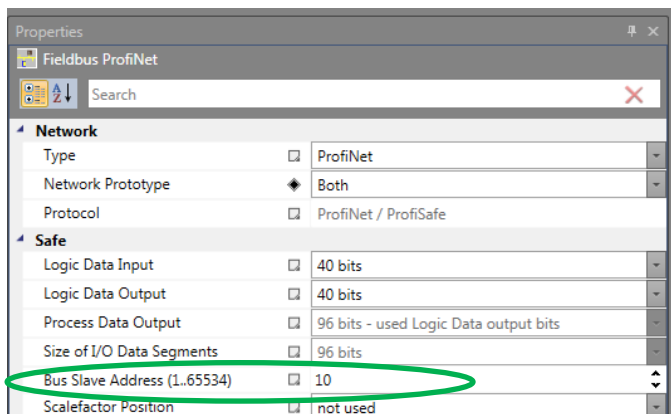
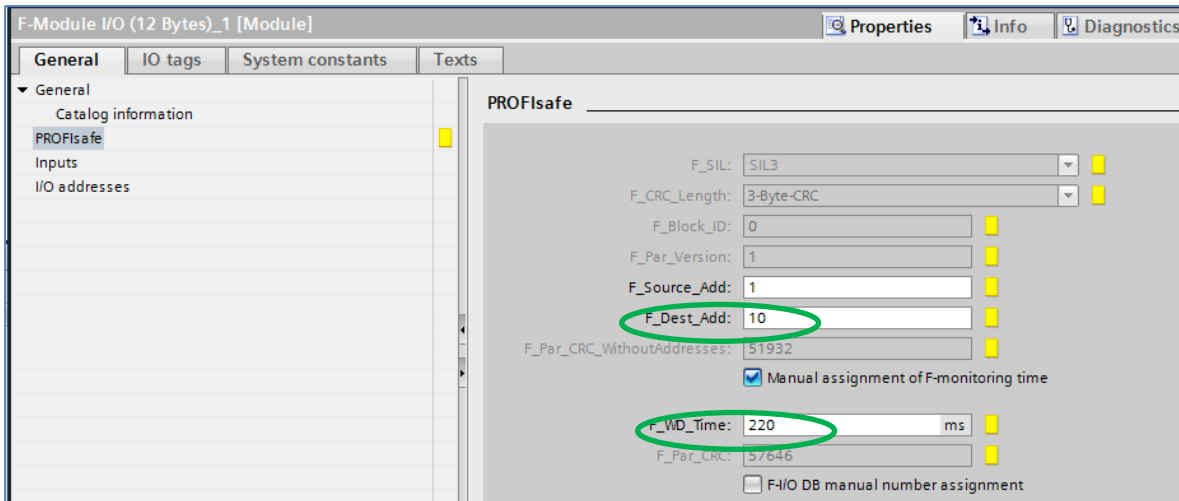

A program call must be defined in the Safety Administration Editor of the program.

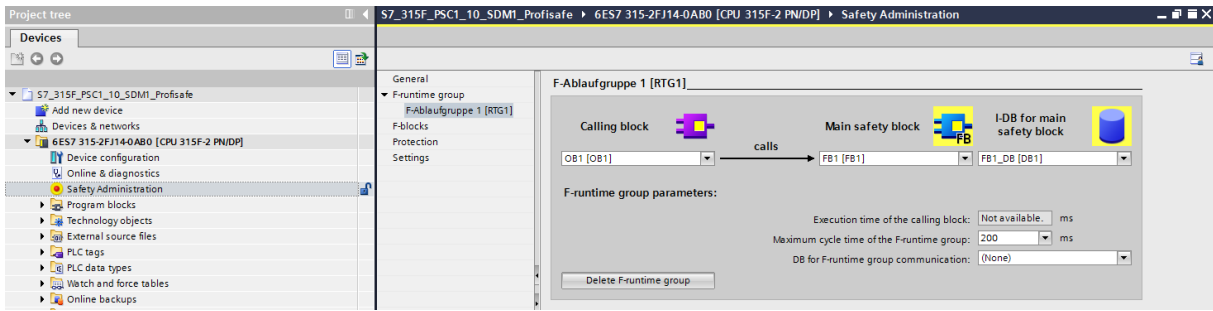

To reintegrate the safe module after an F-peripheral/channel error, an acknowledgement must still be programmed. The acknowledgement request for reintegration is detected via the variable "ACK_REQ" and the acknowledgement for reintegration is sent via the variable "ACK_REI".

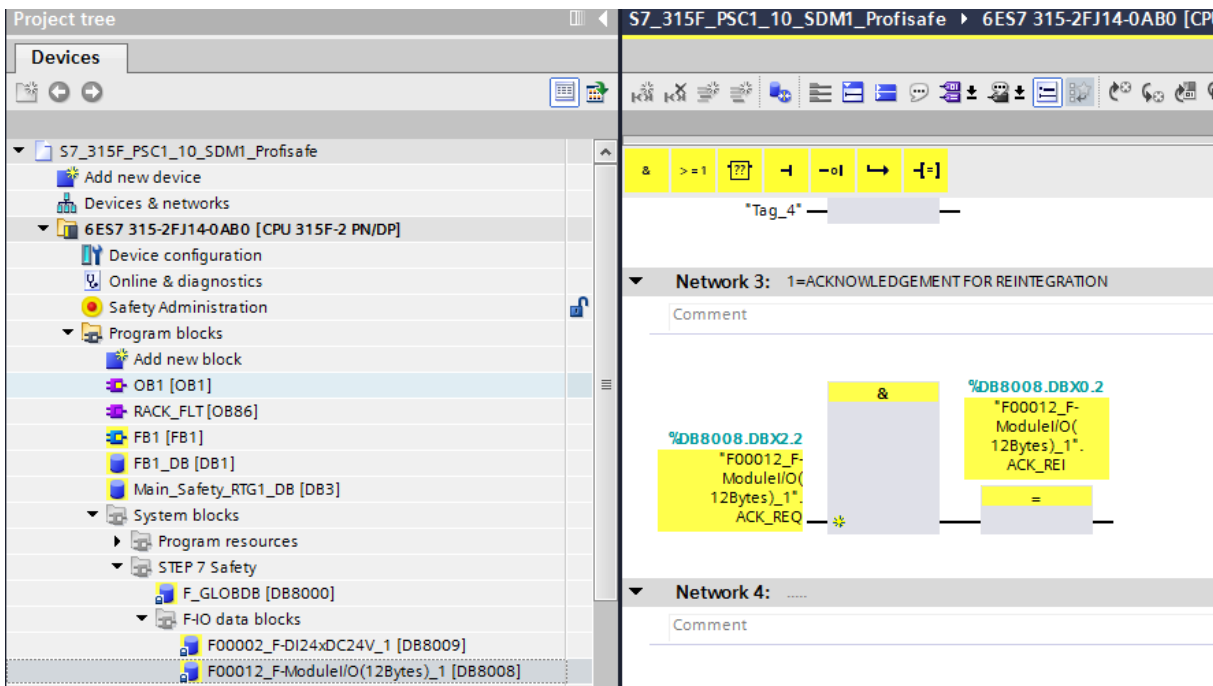

11.1.4 Setting up an online connection

To establish an online connection to the master control, click on "Connect Online" and start the search for compatible devices.

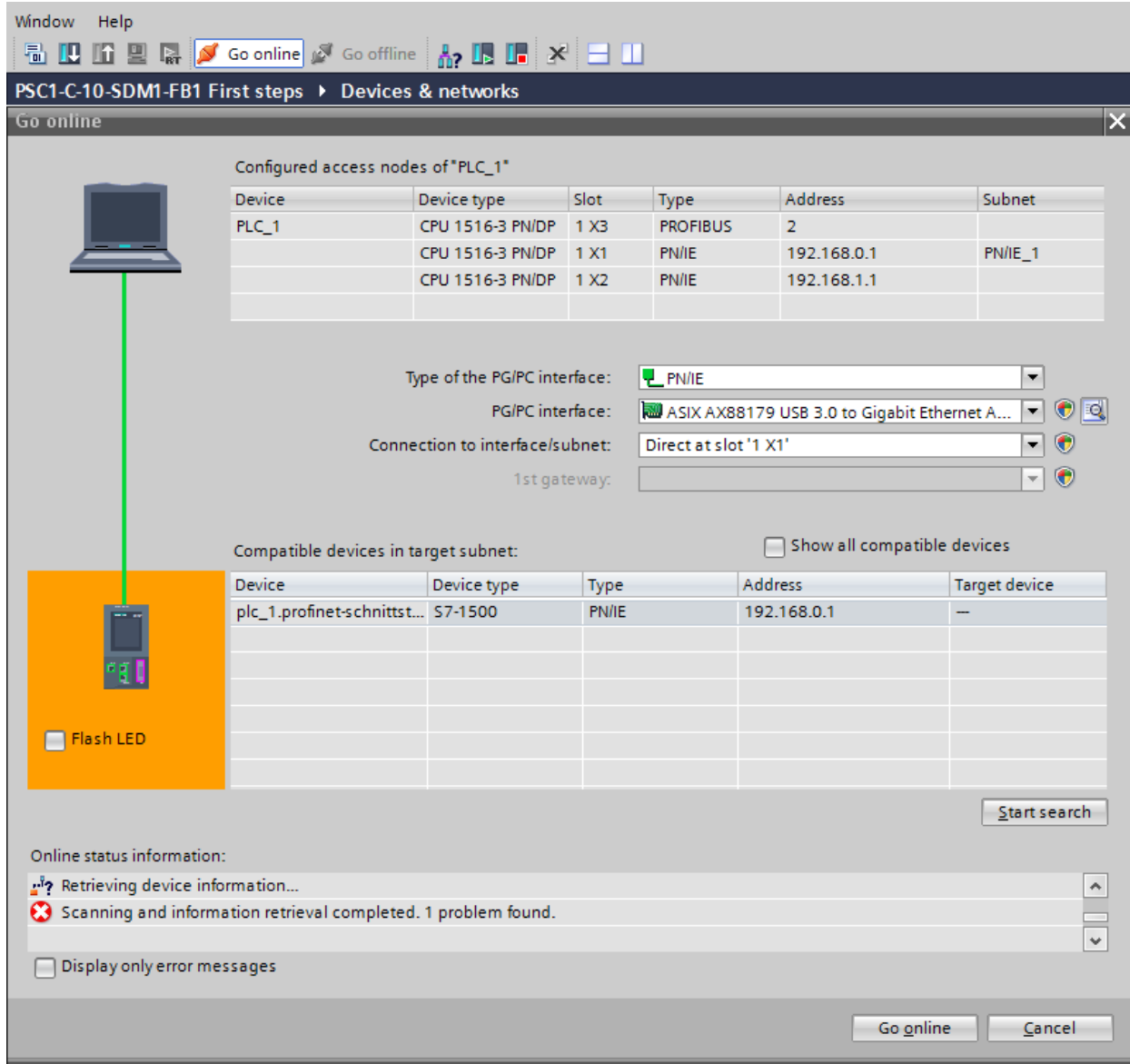

The IP address of the preselected communication card of the PC/PG may still have to be adapted.

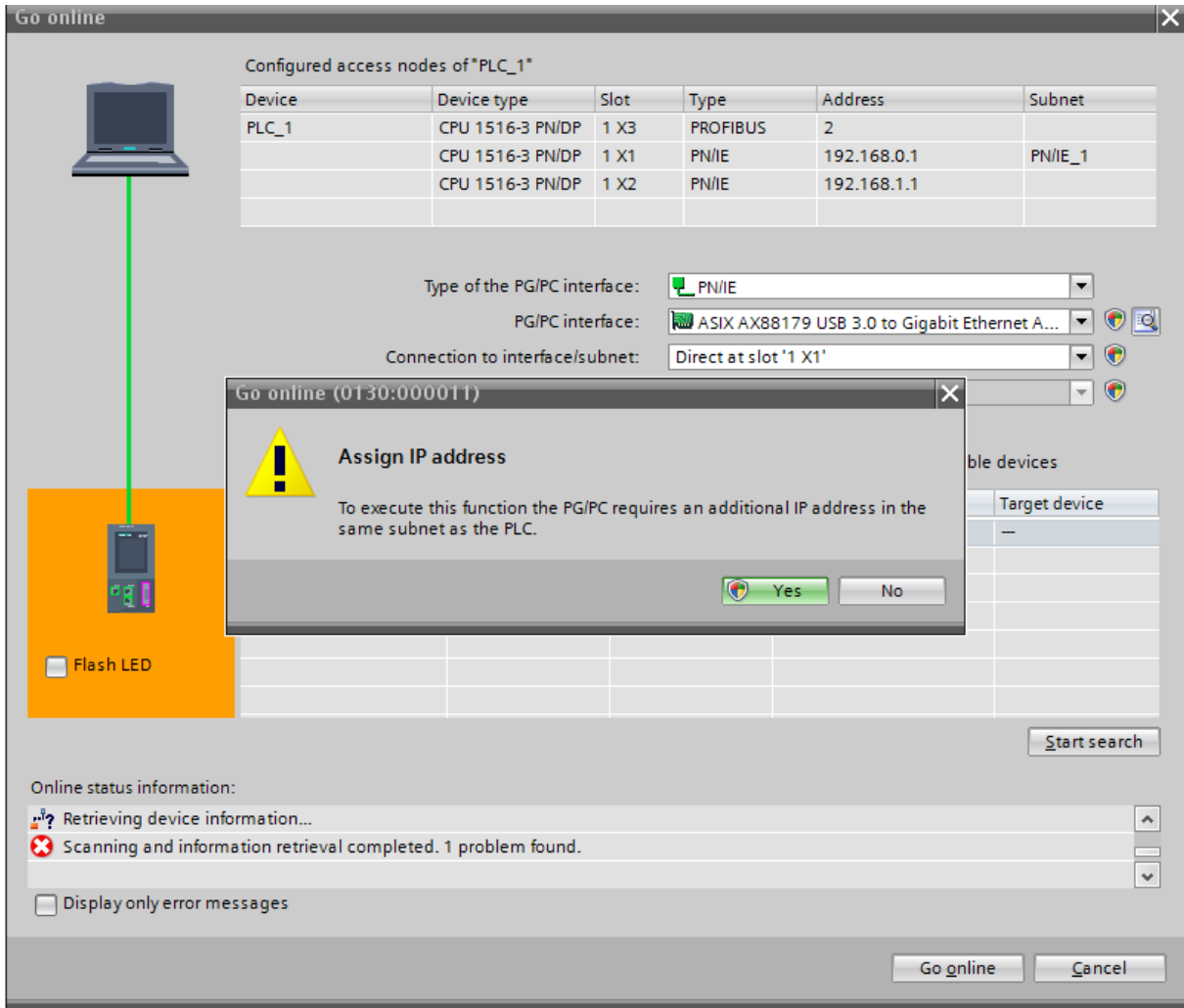

Go online
✕

Configured access nodes of *PLC_1*

Device	Device type	Slot	Type	Address	Subnet
PLC_1	CPU 1516-3 PN/DP	1 X3	PROFIBUS	2	
	CPU 1516-3 PN/DP	1 X1	PN/IE	192.168.0.1	PN/IE_1
	CPU 1516-3 PN/DP	1 X2	PN/IE	192.168.1.1	

Type of the PG/PC interface:

PG/PC interface:

Connection to interface/subnet:

Go online (0130:000008)

An additional IP address was added.

The IP address 192.168.0.241 was added to the interface ASIX AX88179 USB 3.0 to Gigabit Ethernet Adapter.

Flash LED

Start search

Online status information:

- Retrieving device information...
- Scanning and information retrieval completed. 1 problem found.

Display only error messages

Before a PROFINET IO Device can be addressed by a PROFINET IO Controller, a device name must be assigned to the PROFINET IO Device. Double-click on the desired device in the "Device Overview" and then right-click to open the menu dialogue shown below.

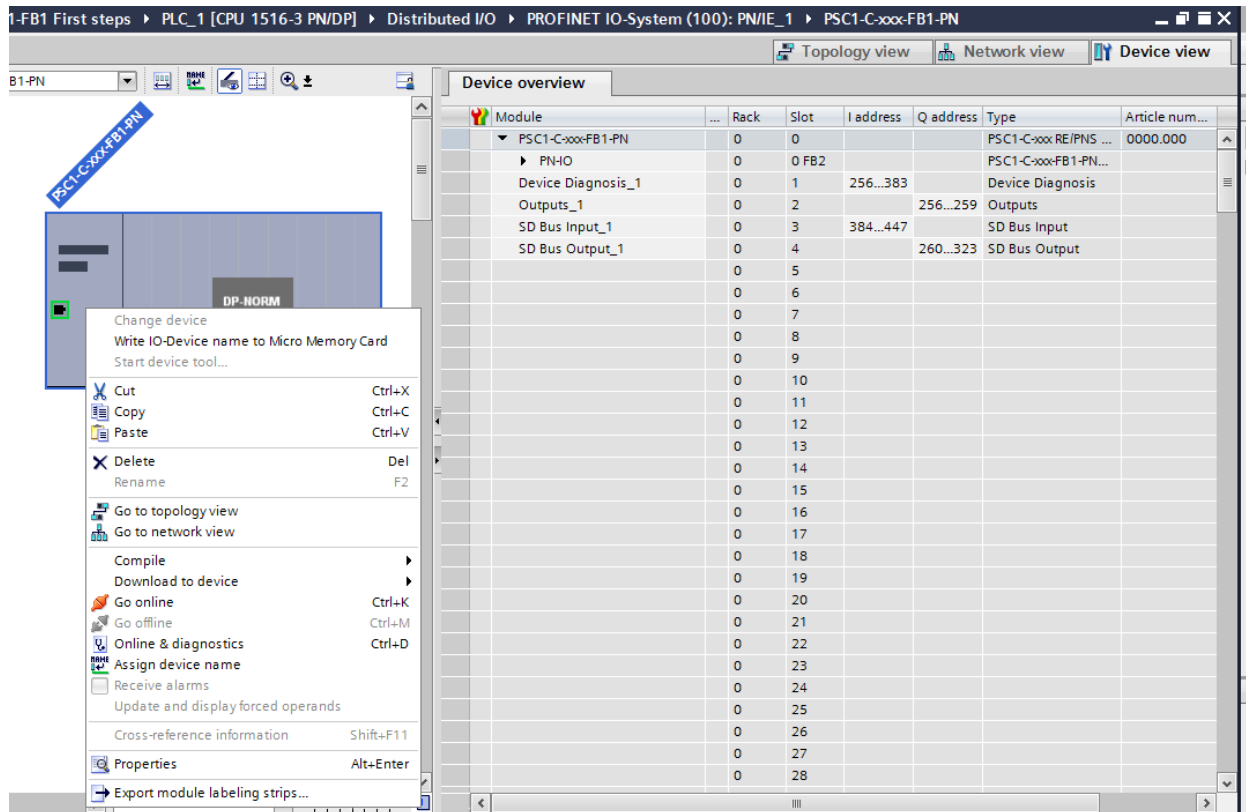

Select the "Assign device name" function.

In the following dialogue, accept or edit the PROFINET device name and confirm the selection with "Assign name".

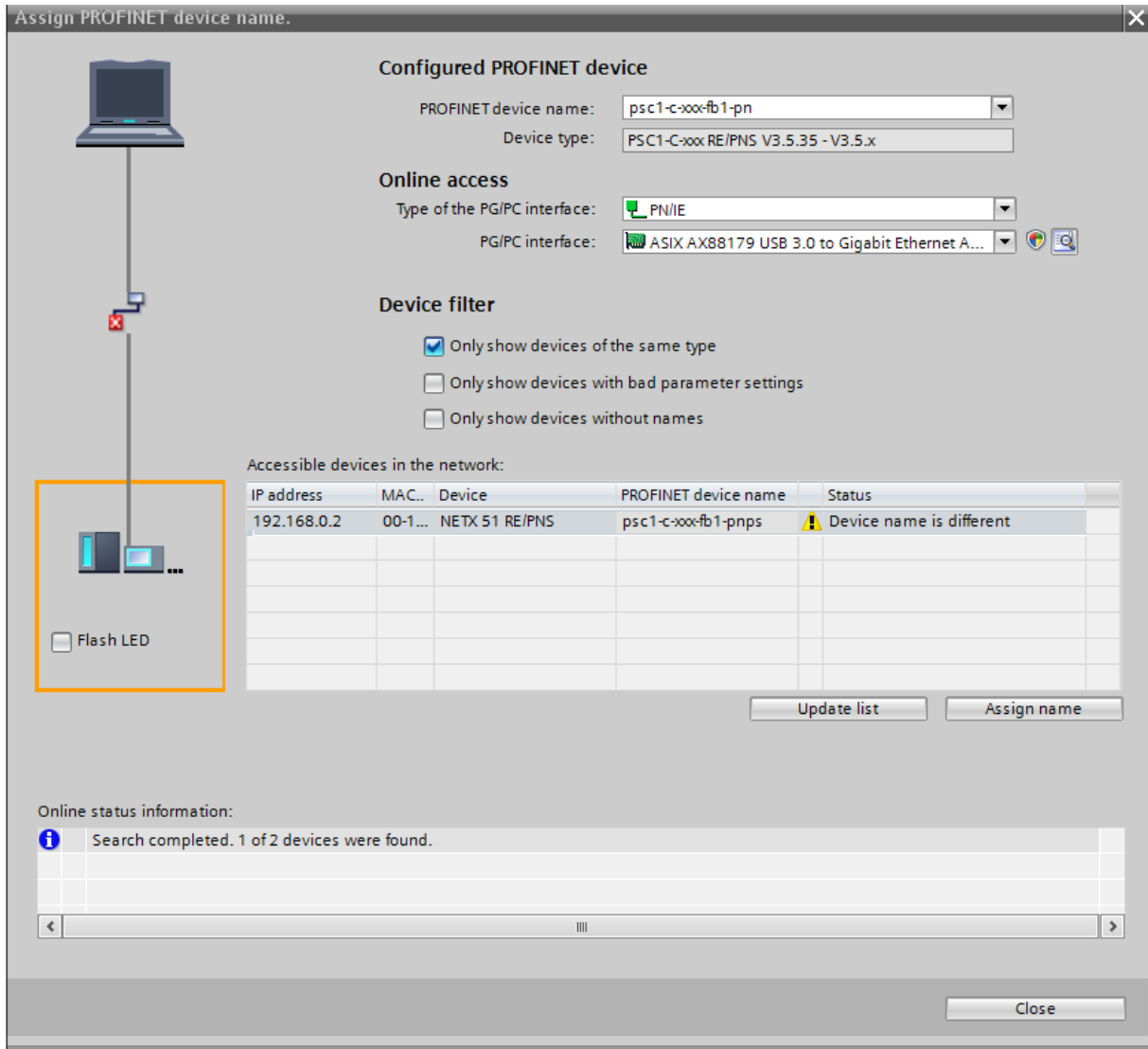

Assign PROFINET device name.

Configured PROFINET device

PROFINET device name: psc1-c-xxx-fb1-pn
Device type: PSC1-C-xxx RE/PNS V3.5.35 - V3.5.x

Online access

Type of the PG/PC interface: PN/IE
PG/PC interface: ASIX AX88179 USB 3.0 to Gigabit Ethernet A...

Device filter

- Only show devices of the same type
- Only show devices with bad parameter settings
- Only show devices without names

Accessible devices in the network:

IP address	MAC...	Device	PROFINET device name	Status
192.168.0.2	00-1...	NETX 51 RE/PNS	psc1-c-xxx-fb1-pnps	⚠ Device name is different

Flash LED

Update list Assign name

Online status information:
Search completed. 1 of 2 devices were found.

Close

After a successful change, the status changes to "OK".

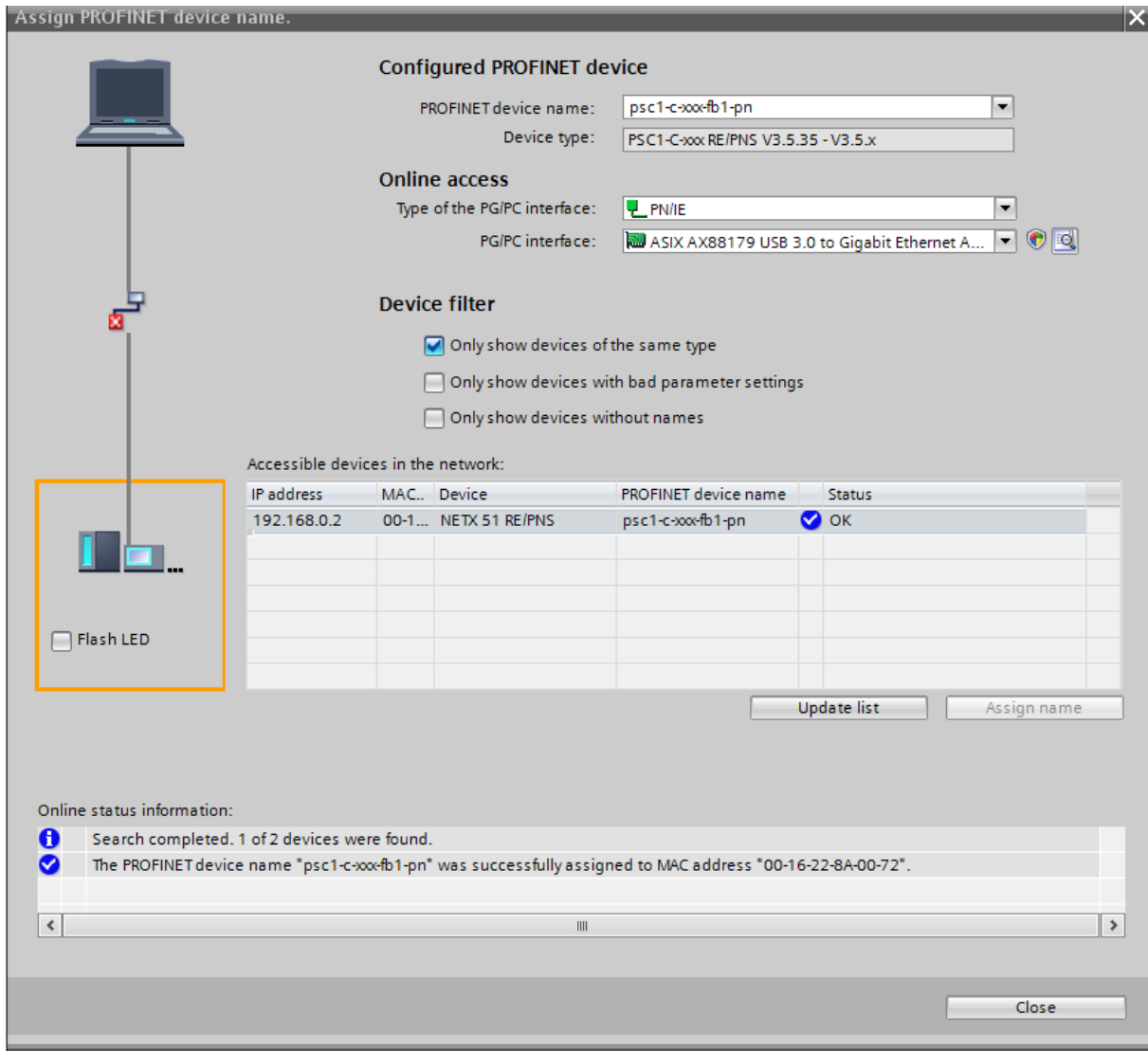

Signal states can now be observed in the "Observe Variables" dialogue.

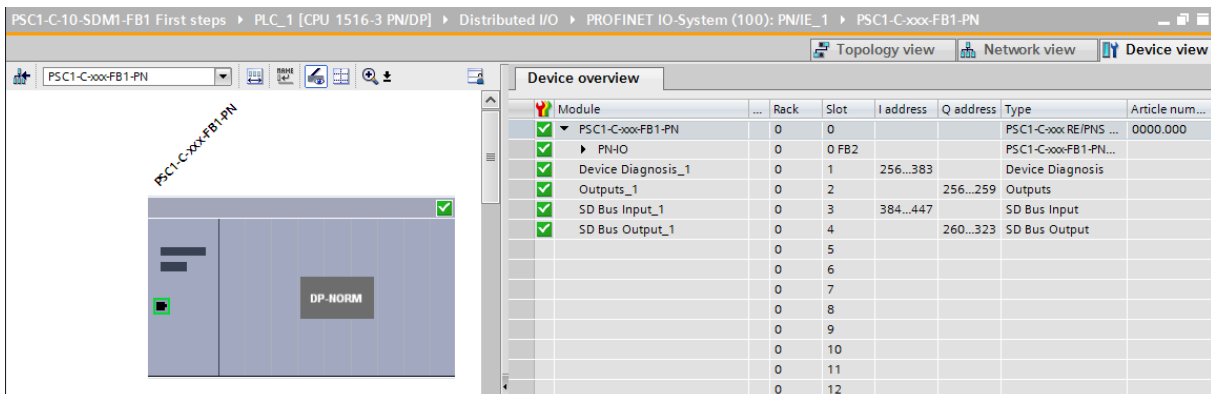

11.1.5 Examples of non-safe data transmission

In the following example, the switching state of the button "Confirm Button 1" is written to SafePLC2 in bit 0 (functional output) and can be read in byte 5 (bit 0) of the configuration tool (TIA Portal).

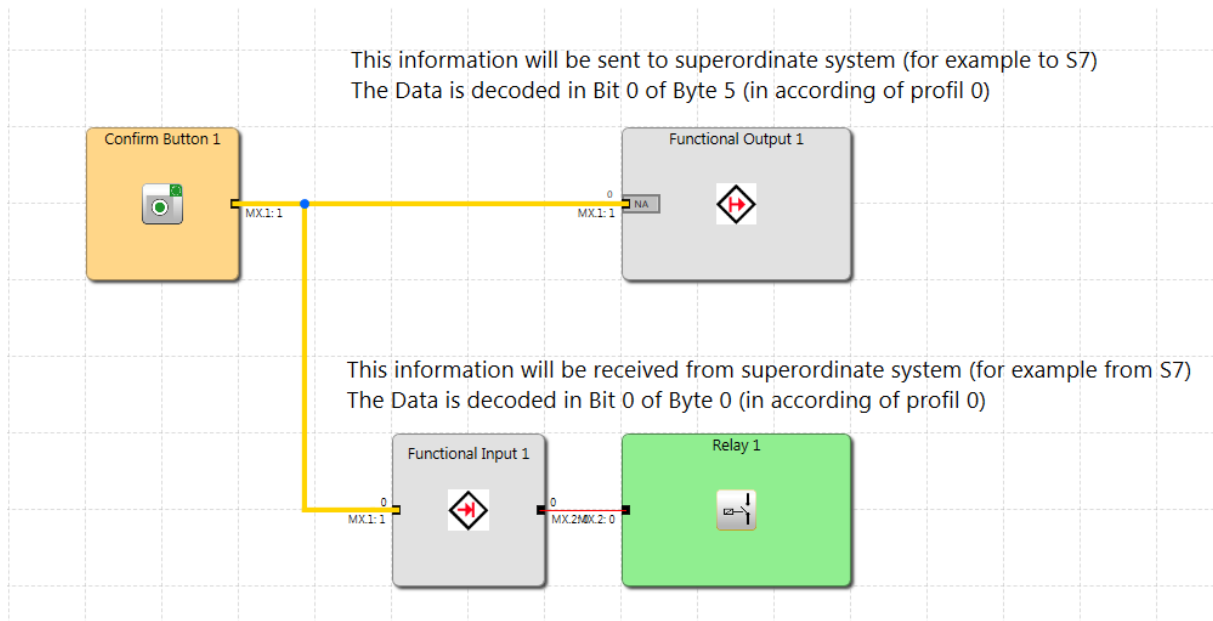

PSC1-C-10-SDM1-FB1 First steps > PLC_1 [CPU 1516-3 PN/DP] > Watch and force tables > Watch table_1

i	Name	Address	Display format	Monitor value	Modify value		Comment
1		%EB256	Bin	2#0001_0100		<input type="checkbox"/>	Byte 0 // Status of PSC1 and alive counter
2		%EB257	Bin	2#0000_0000		<input type="checkbox"/>	Byte 1 // Logicdata [Bit ID 48..55]
3		%EB258	Bin	2#0000_0000		<input type="checkbox"/>	Byte 2 // Logicdata [Bit ID 40..47]
4		%EB259	Bin	2#0000_0000		<input type="checkbox"/>	Byte 3 // Logicdata [Bit ID 32..39]
5		%EB260	Bin	2#0000_0000		<input type="checkbox"/>	Byte 4 // Logicdata [Bit ID 08..15]
6		%EB261	Bin	2#0000_00 1		<input type="checkbox"/>	Byte 5 // Logicdata [Bit ID 00..07]
7		%EB262	Bin	2#0000_0000		<input type="checkbox"/>	Byte 6 // Logicdata [Bit ID 24..30] +error code [high byte]
8		%EB263	Bin	2#0000_0000		<input type="checkbox"/>	Byte 7 // Logicdata [Bit ID 16..23] +error code [low byte]

In addition, up to 32 non-safe functional inputs are available on the PSC1, via which digital information can be received from the higher-level standard controller. In the "SafePLC2" function diagram, these inputs must always be AND-linked to a safe input and can then be reused as required.

In the following example, the functional output (Byte0, Bit 0) is written in the higher-level standard control and AND-linked to a safe input in PSC1 (Confirm Button 1). Both have a high signal, relay 1 is activated.

9	%AB256	Bin	2#0000_0001	2#0000_0001	<input checked="" type="checkbox"/>	Byte 1 // Functional Output [Bit ID 00..07]
10	%AB257	Bin	2#0000_0000		<input type="checkbox"/>	Byte 2 // Functional Output [Bit ID 08..15]
11	%AB258	Bin	2#0000_0000		<input type="checkbox"/>	Byte 3 // Functional Output [Bit ID 16..23]
12	%AB259	Bin	2#0000_0000		<input type="checkbox"/>	Byte 4 // Functional Output [Bit ID 24..31]

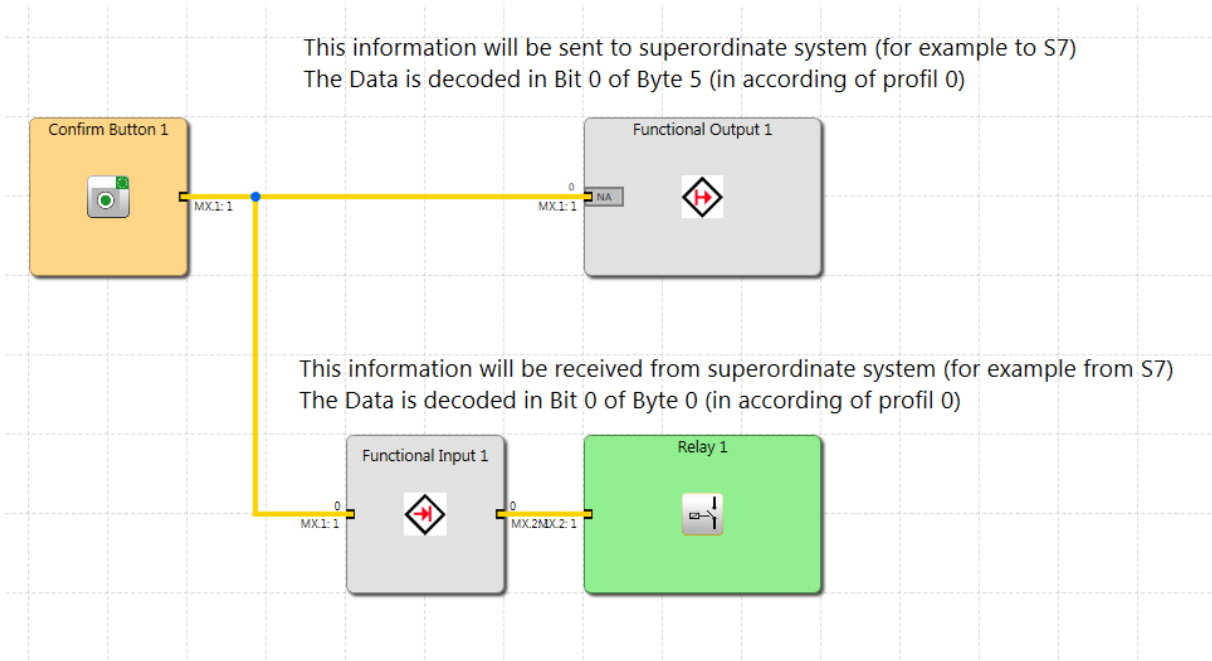

In the following example, the functional output (Byte0, Bit 0) is written in the higher-level standard control and AND-linked to a safe input in PSC1 (Confirm Button 1). "Confirm Button 1" has a low signal, the functional output from the standard control has a high signal, Relay 1 is not activated.

9	%AB256	Bin	2#0000_0001	2#0000_0001	<input checked="" type="checkbox"/>	Byte 1 // Functional Output [Bit ID 00..07]
10	%AB257	Bin	2#0000_0000		<input type="checkbox"/>	Byte 2 // Functional Output [Bit ID 08..15]
11	%AB258	Bin	2#0000_0000		<input type="checkbox"/>	Byte 3 // Functional Output [Bit ID 16..23]
12	%AB259	Bin	2#0000_0000		<input type="checkbox"/>	Byte 4 // Functional Output [Bit ID 24..31]

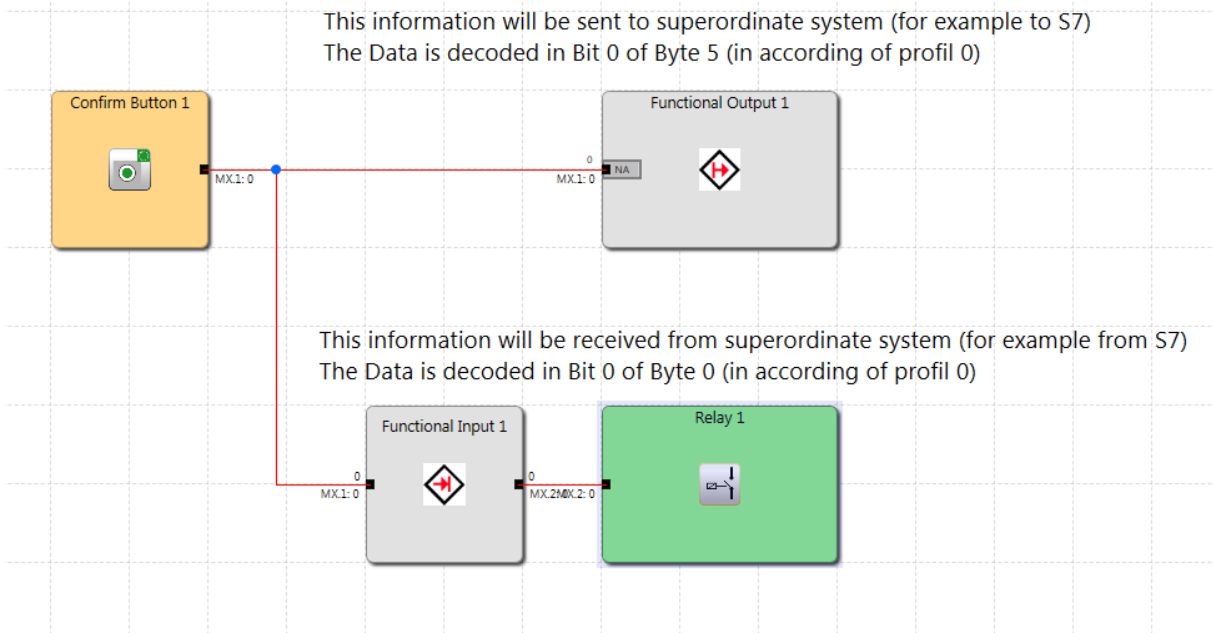

11.1.6 Examples of safe data transmission

In the following example, the switching state of the button "Confirm Button 1" is written to PSC1 in bit 1 (f bus output 1) and can be read in byte 0 (bit 0, F bus 00..07) of the configuration tool (TIA Portal).

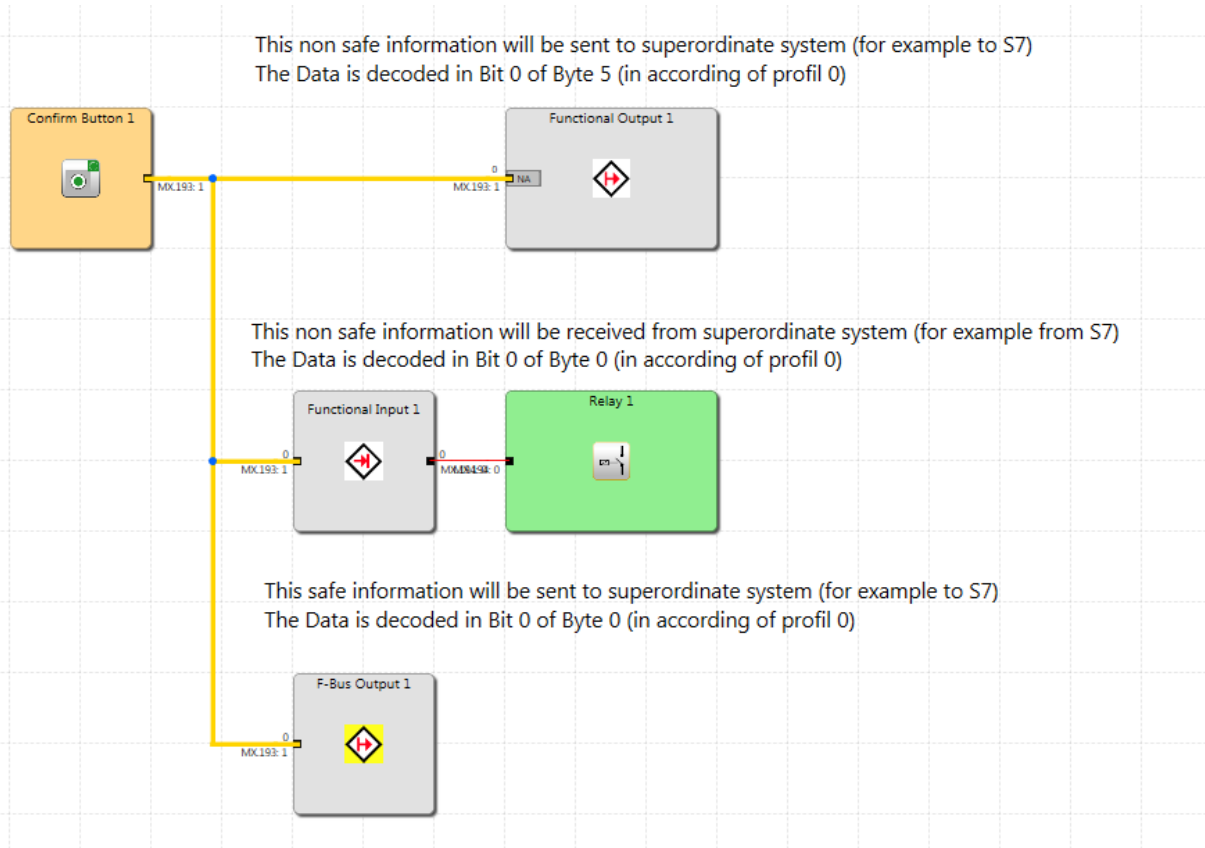

i	Name	Adresse	Anzeigeformat	Beobachtungswert	Steuerwert	⚡
1	*F-Bus 00..07*	%EB12	Bin	2#0000_0001		<input type="checkbox"/>
2	*F-Bus IN 08..15*	%EB13	Bin	2#0000_0000		<input type="checkbox"/>
3	*F-Bus IN 16..23*	%EB14	Bin	2#0000_0000		<input type="checkbox"/>
4	*F-Bus IN 24..32*	%EB15	Bin	2#0000_0000		<input type="checkbox"/>
5	*F-Bus IN 32..39*	%EB16	Bin	2#0000_0000		<input type="checkbox"/>
6	*F-Bus IN 40..47*	%EB17	Bin	2#0000_0000		<input type="checkbox"/>
7	*F-Bus IN 48..55*	%EB18	Bin	2#0000_0000		<input type="checkbox"/>
8	*F-Bus IN 56..63*	%EB19	Bin	2#0000_0000		<input type="checkbox"/>
9	*F-Bus IN 64..71*	%EB20	Bin	2#0000_0000		<input type="checkbox"/>
10	*F-Bus IN 72..79*	%EB21	Bin	2#0000_0000		<input type="checkbox"/>
11	*F-Bus IN 80..88*	%EB22	Bin	2#0000_0000		<input type="checkbox"/>
12	*F-Bus IN 89..96*	%EB23	Bin	2#0000_0000		<input type="checkbox"/>
13	*F-Bus CRC Byte 1*	%EB24	Hex	16#20		<input type="checkbox"/>
14	*F-Bus CRC Byte 2*	%EB25	Hex	16#69		<input type="checkbox"/>
15	*F-Bus CRC Byte 3*	%EB26	Hex	16#1A		<input type="checkbox"/>
16	*F-Bus CRC Byte 4*	%EB27	Hex	16#04		<input type="checkbox"/>

The last four bytes are intended for CRC control.

In addition, up to 96 safe functional inputs are available on the PSC1, via which digital information can be received by the higher-level safety controller.

In the following example, the functional output (F_Bus byte 0. bit 0) is written in the safety controller and read in the PSC1 in bit 0 (F bus input 1) and output to relay 2.

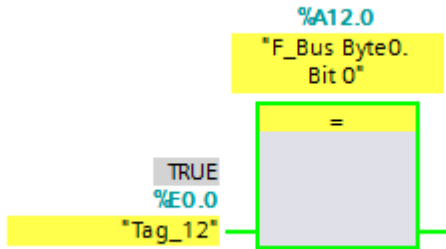

17	"F-Bus OUT 00..07"	%AB12	Bin	2#0000_0001
----	--------------------	-------	-----	-------------

This safe information will be received from superordinate system (for example from S7)
 The Data is decoded in Bit 0 of Byte 0 (safety data block)



12 Commissioning and configuration EtherNet/IP in SafePLC2 and RSLogix500

EtherNet/IP is available for all PSC1 base devices with the "-FB1" option. The "-FB1" option is always permanently integrated in the base device and represents the gateway from the CAN-based backplane bus of the PSC1 series to EtherNet/IP. It enables the user to exchange data bidirectionally via EtherNet/IP with a higher-level controller.

In the properties of the PSC1 base device, the:

- **Local Network** - the property **fieldbus** is activated,

and in the **fieldbus properties (Fieldbus EtherNet/IP)** under:

- **Type – EtherNet/IP**

must be selected.

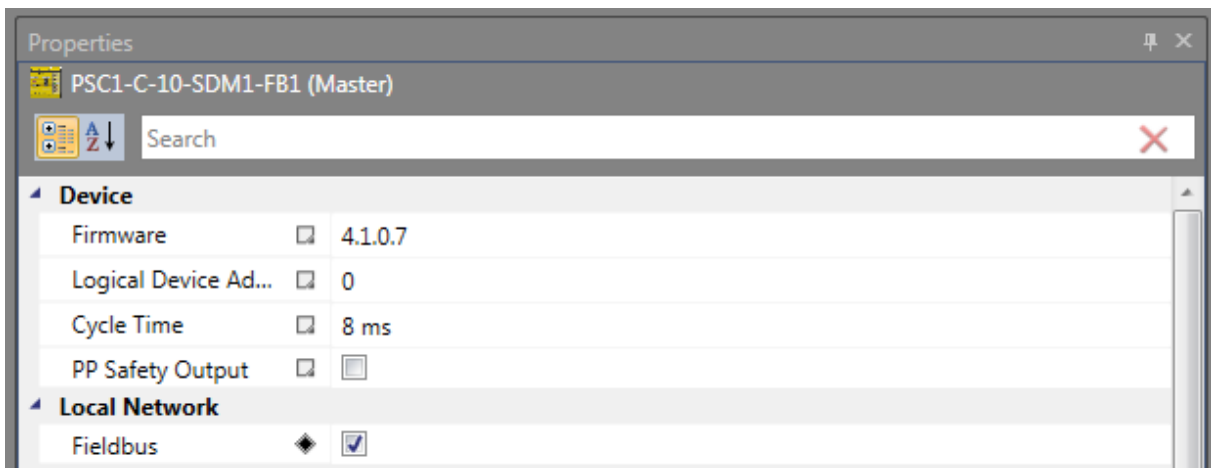

Figure 17: Properties PSC1 basic device - EtherNet/IP

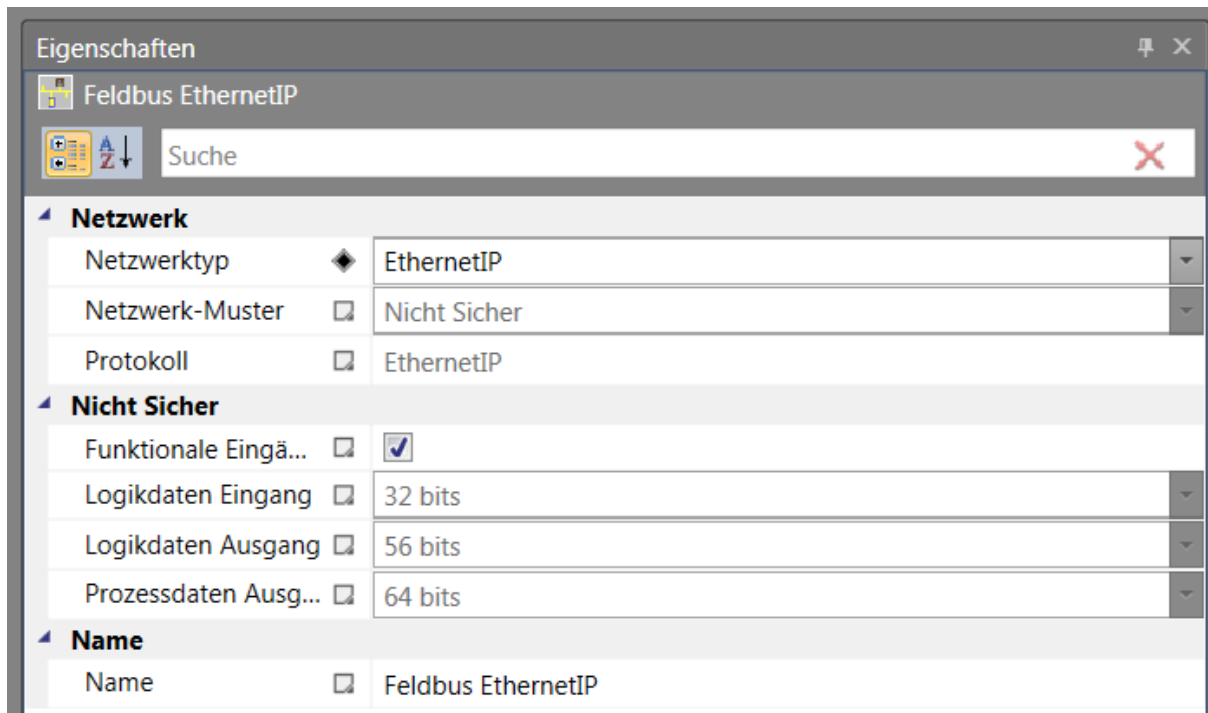
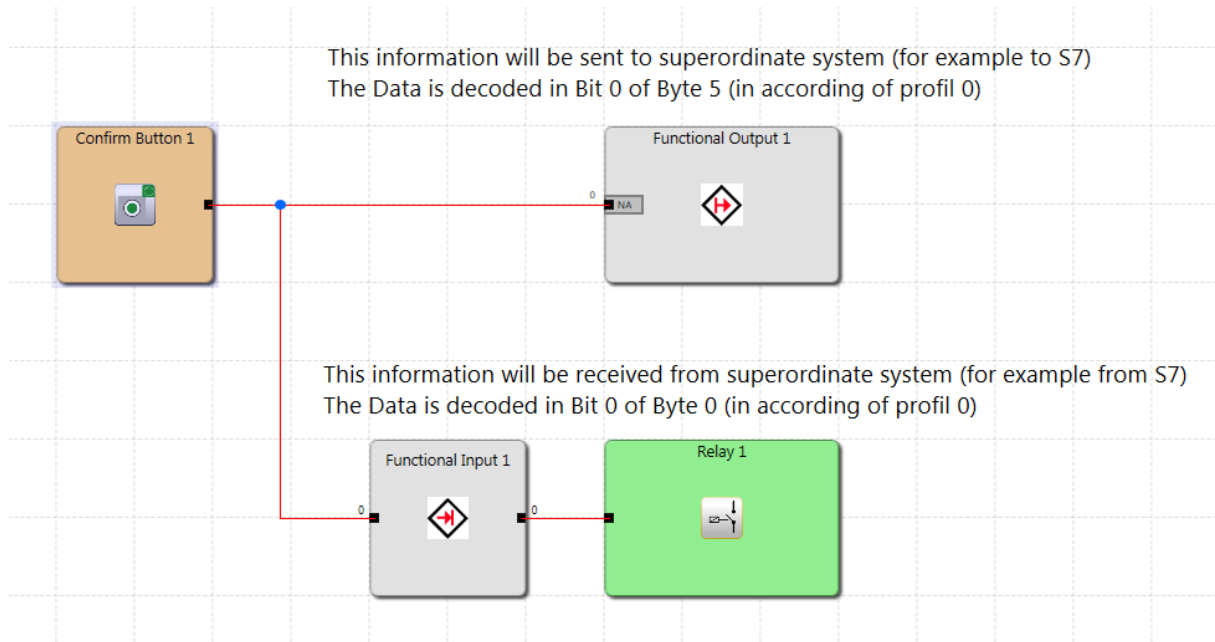

Figure 18: Properties fieldbus (Feldbus EtherNet/IP) - non-safe

The functional inputs and outputs must still be inserted in the "Functional scheme" and logically connected.



The project and the network configuration must be transferred:
"Click the "Device Interface" icon



Click the "Connect" icon in the new dialogue.

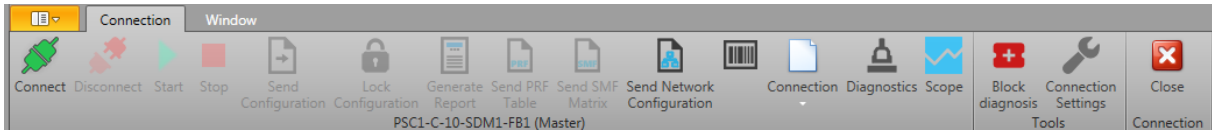

The successful connection to PSC1 is displayed in the following dialogue ("Connect icon" faded out / "Disconnect icon" faded in).

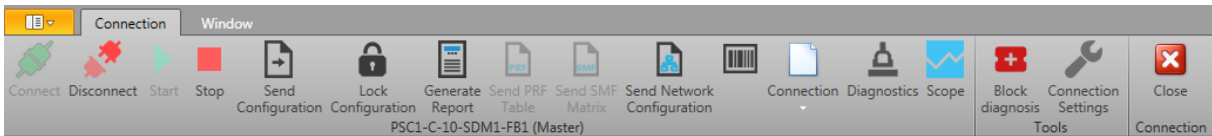

Now the network configuration and the source code can be transferred.

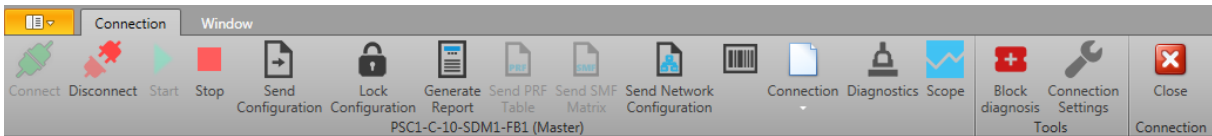

The transfer status (progress bar) is displayed in the lower information bar.

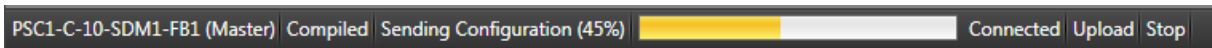

After transmission, the PSC1 may have to be restarted ("Green arrow icon").

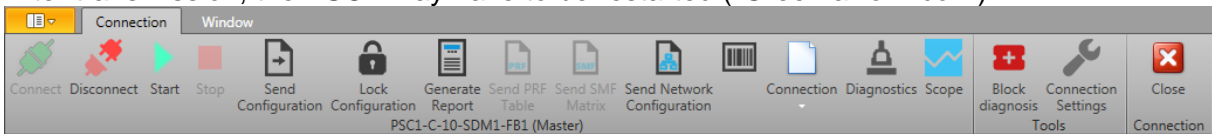

12.1 Parameter configuration

The parameters are set using the RSLogix5000 program from Rockwell Automation, Inc.

12.1.1 Create project

On the menu, click File > New > Project and create a new RSLogix5000 project.

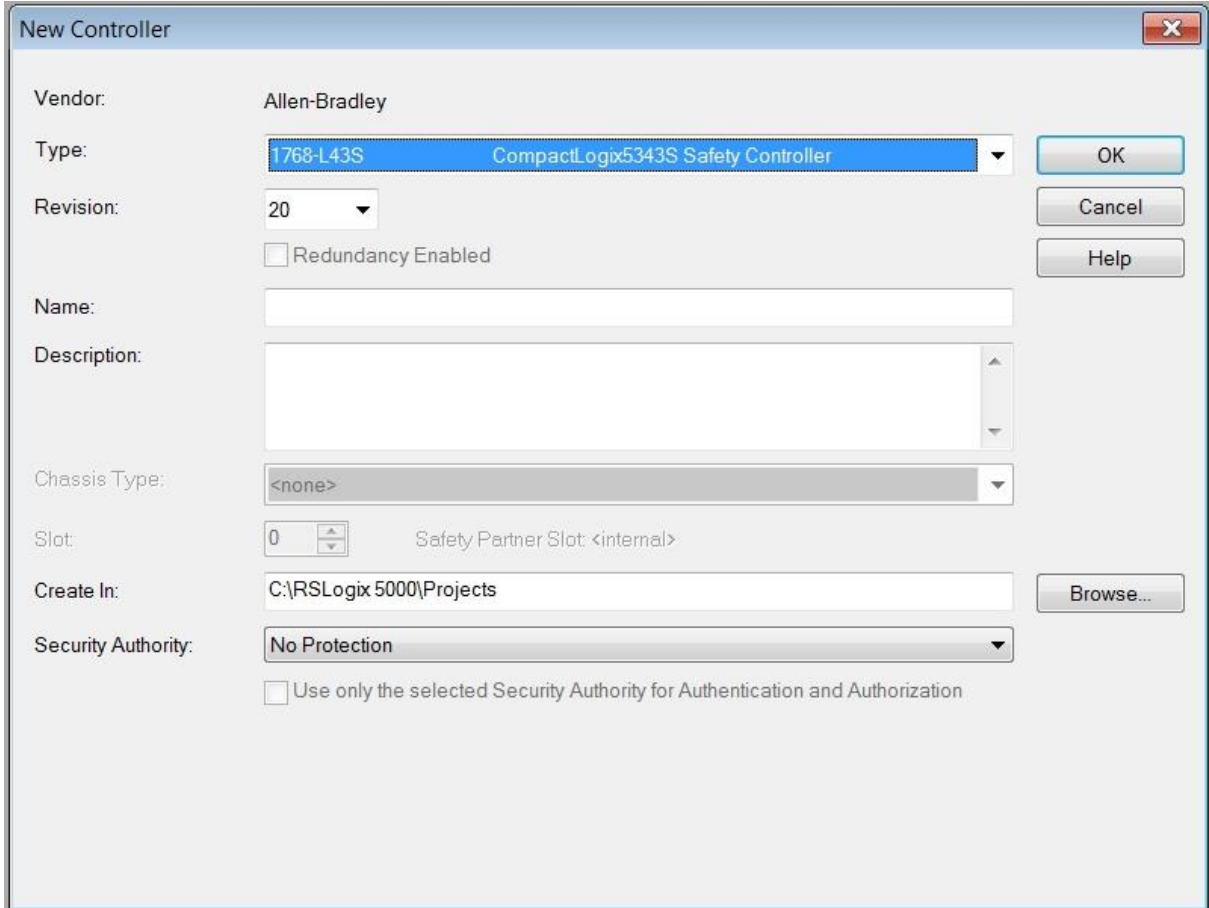

The screenshot shows the 'New Controller' dialog box with the following settings:

- Vendor: Allen-Bradley
- Type: 1768-L43S CompactLogix5343S Safety Controller
- Revision: 20
- Redundancy Enabled
- Name: (empty text box)
- Description: (empty text box)
- Chassis Type: <none>
- Slot: 0 Safety Partner Slot: <internal>
- Create In: C:\RSLogix 5000\Projects
- Security Authority: No Protection
- Use only the selected Security Authority for Authentication and Authorization

Buttons: OK, Cancel, Help, Browse...

In the tree view, right-click on "... Bus" and in the context menu on "New Module".

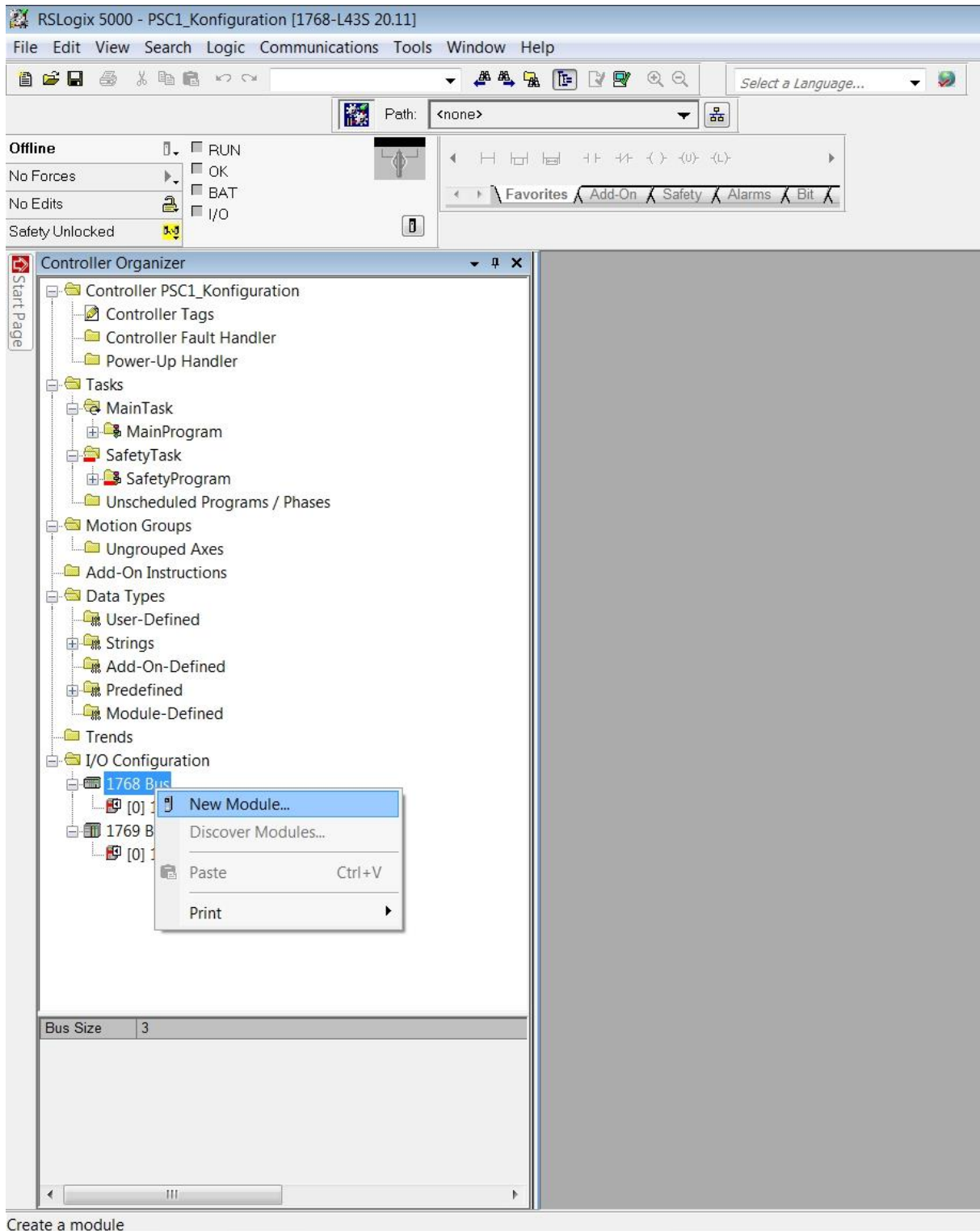

Select the desired communication card and click on "Create".

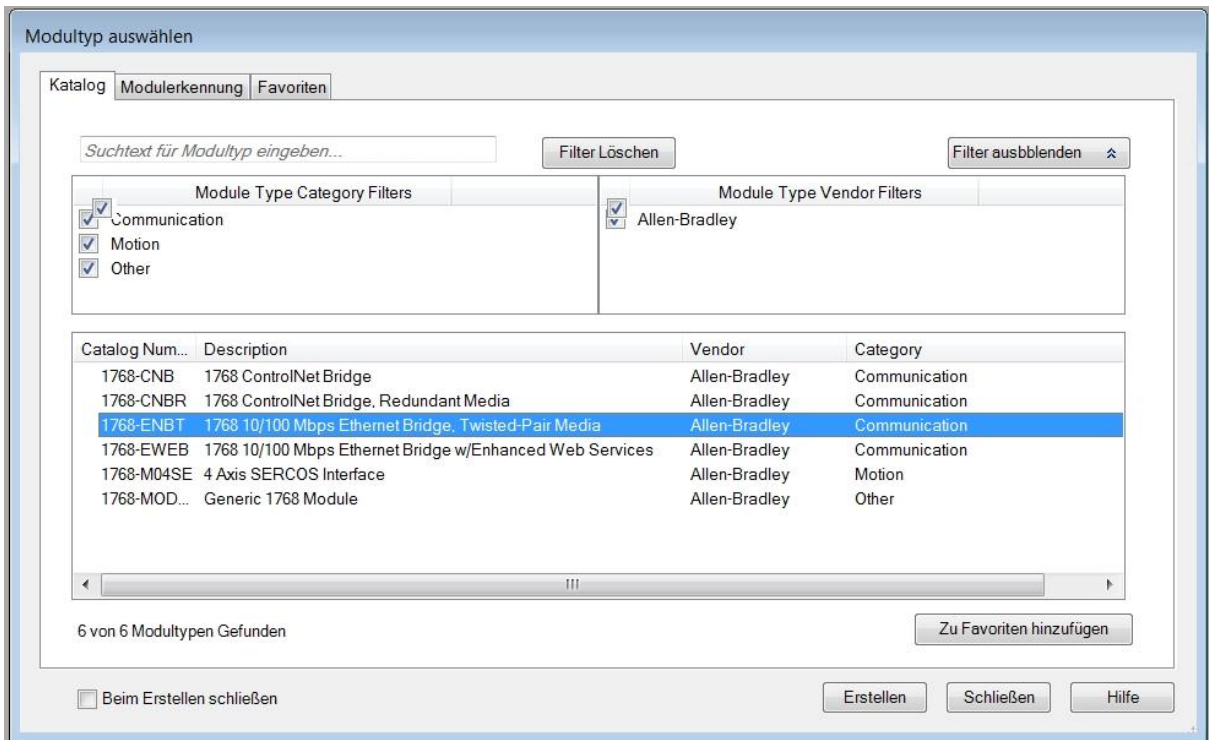

Then enter the IP address of your network card and confirm with "OK".

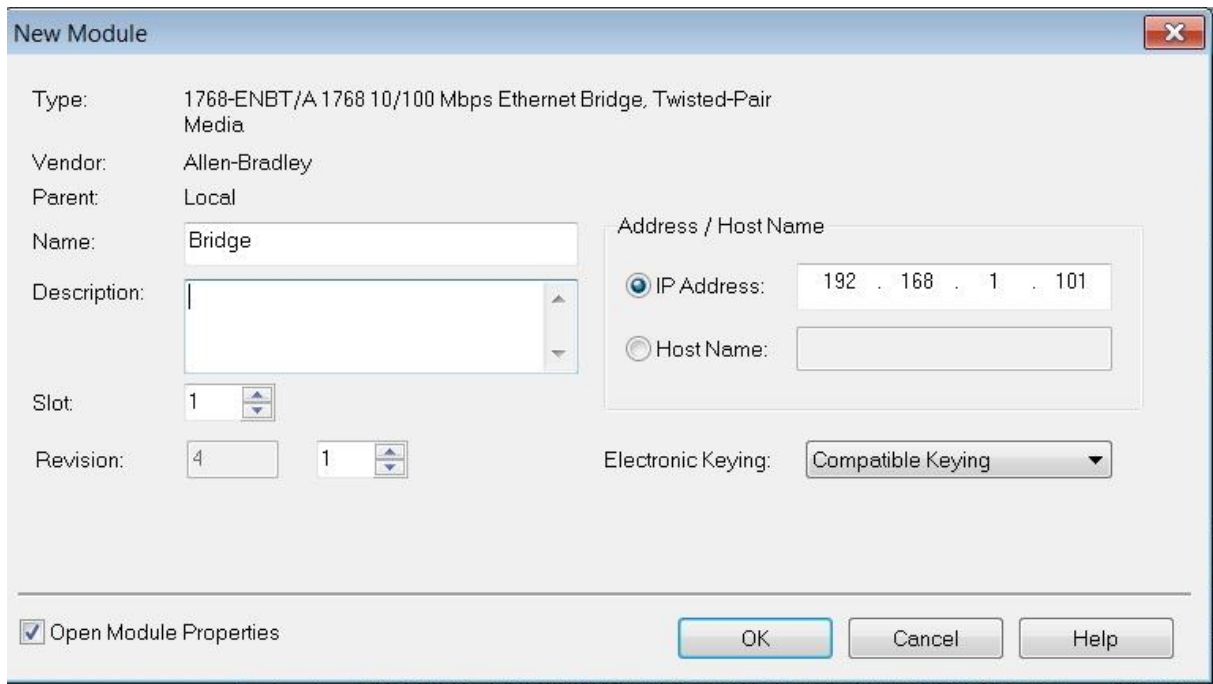

12.1.2 Installing the EDS file

Click on "Tools" => "EDS Hardware Installation Tool".

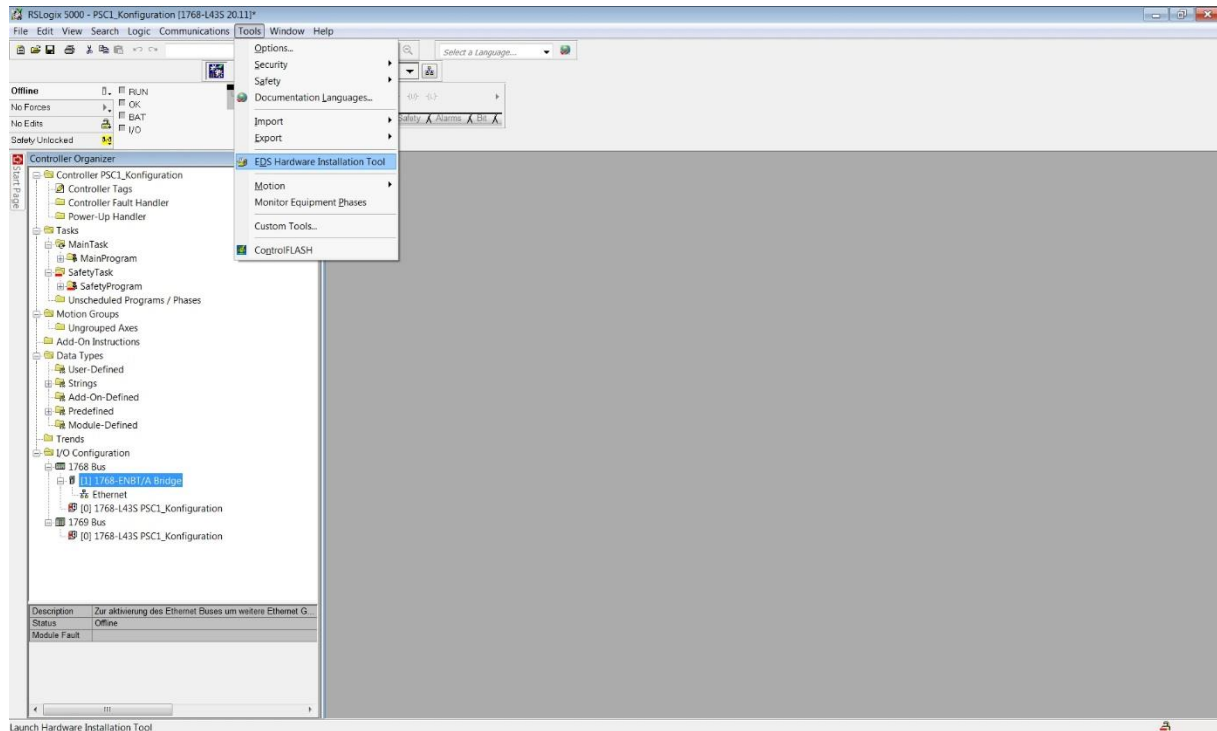

If necessary, confirm that you want to start the installation tool.



Select "Register to EDS file(s)" and click "Next".



Select the EDS file and click "Next".

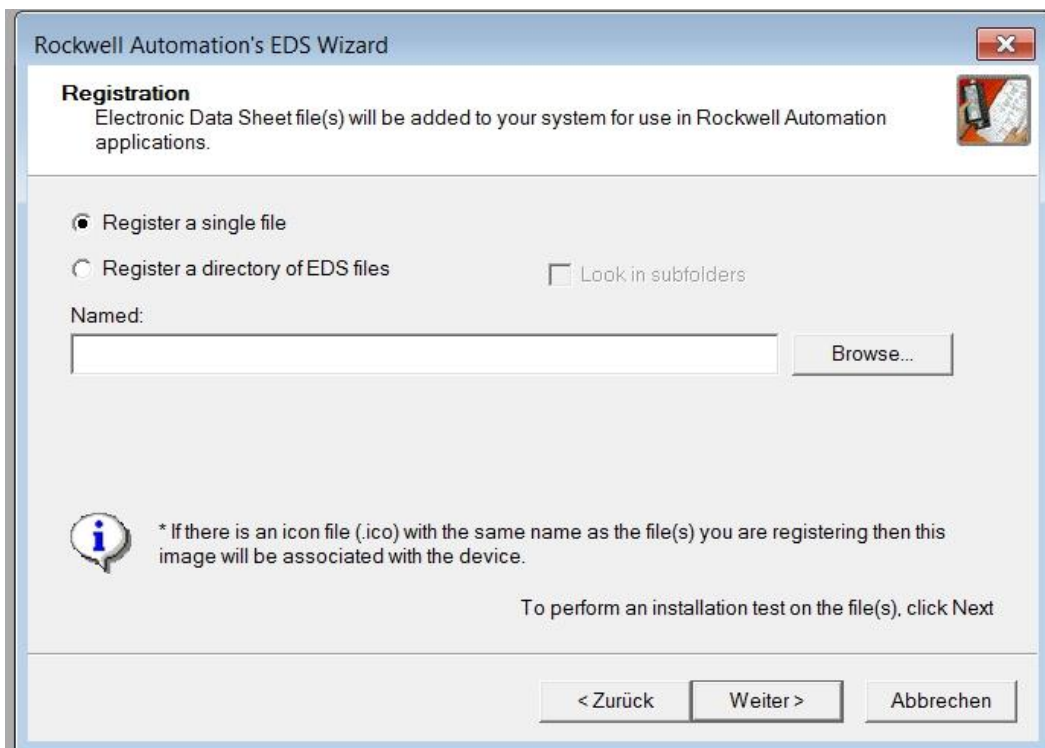

The EDS file is checked.

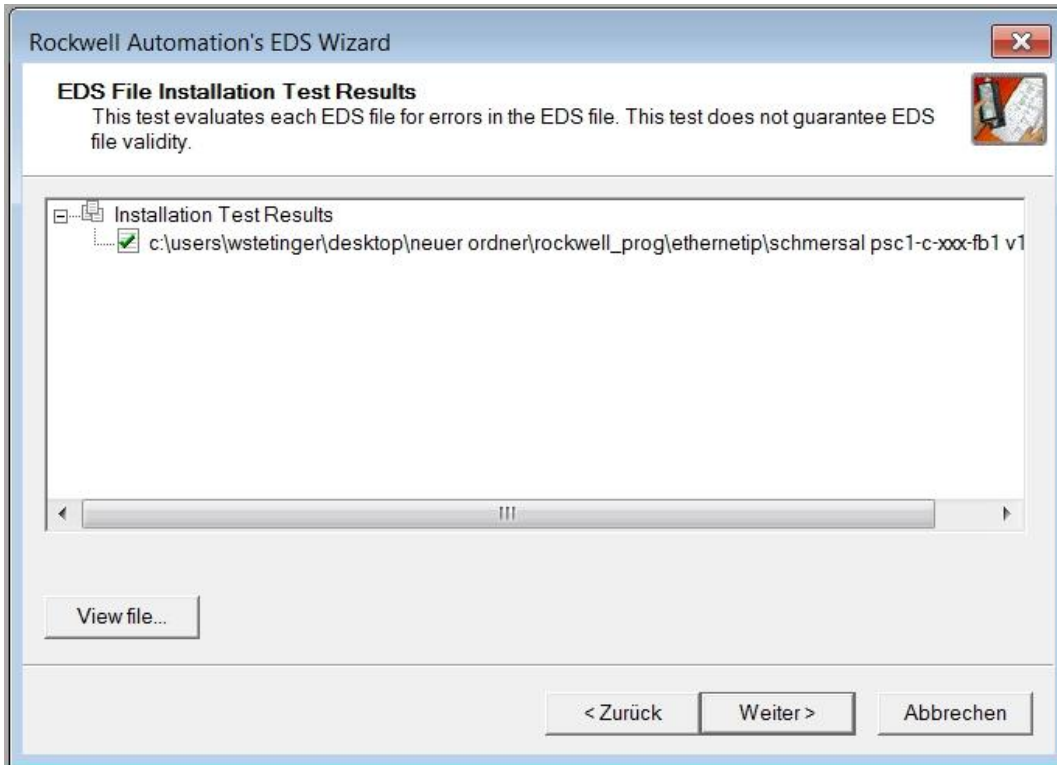

In the following, it is possible to change the graphical image of the slave (not recommended). Click on "Next".

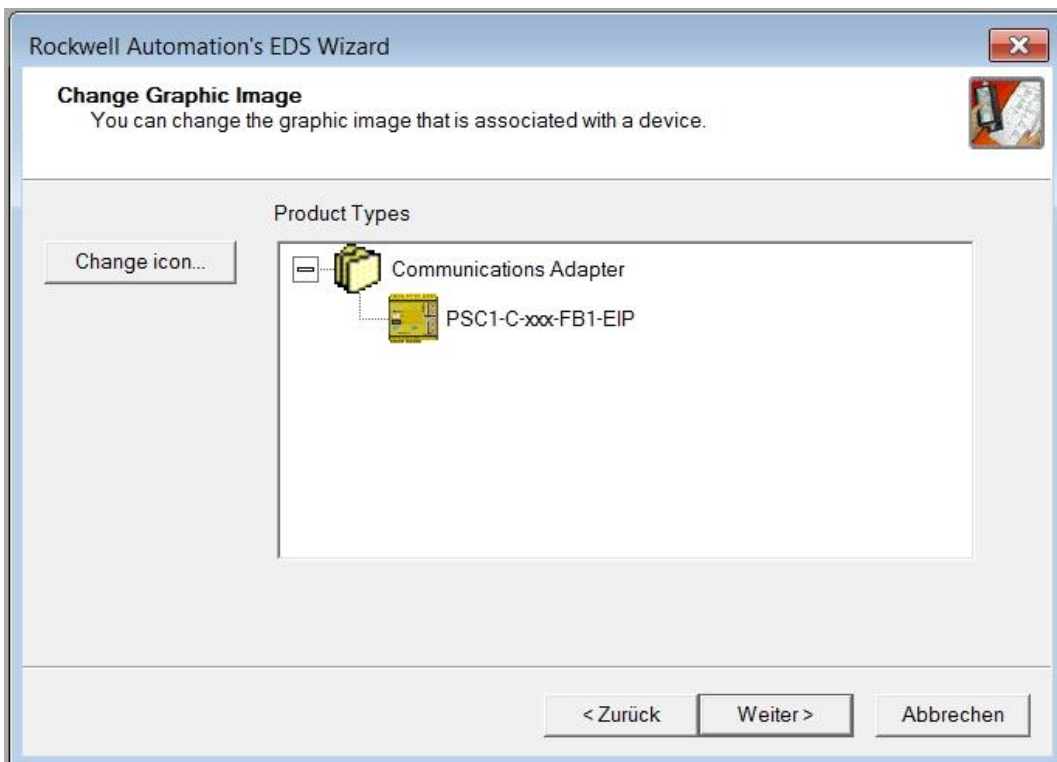

The following window gives a short summary of the installation. Click on "Next".

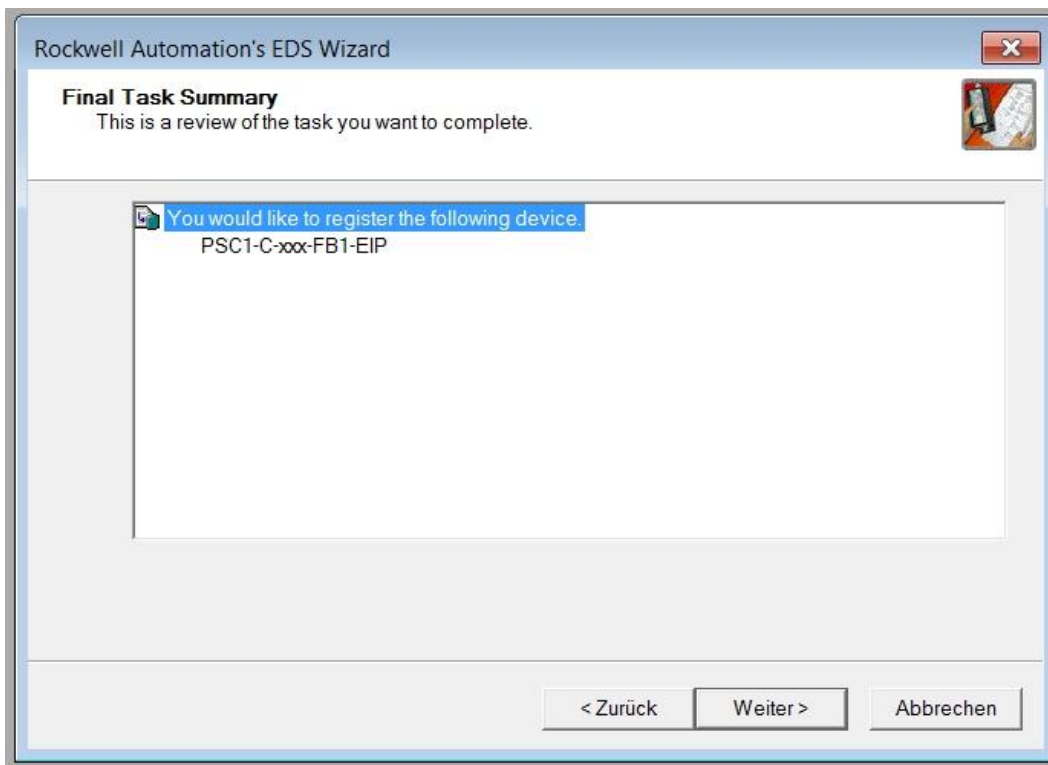

Then click on "Finish".

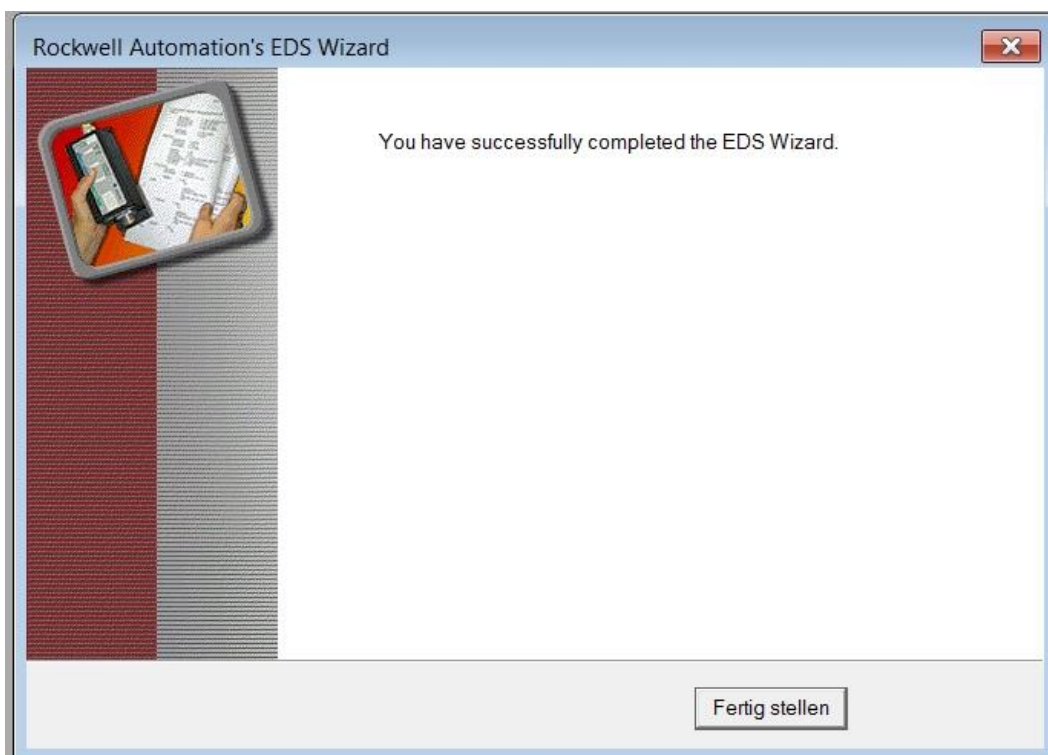

12.1.3 Insert PSC1

In the tree view, right-click "Ethernet" and then "New Module" in the context menu.

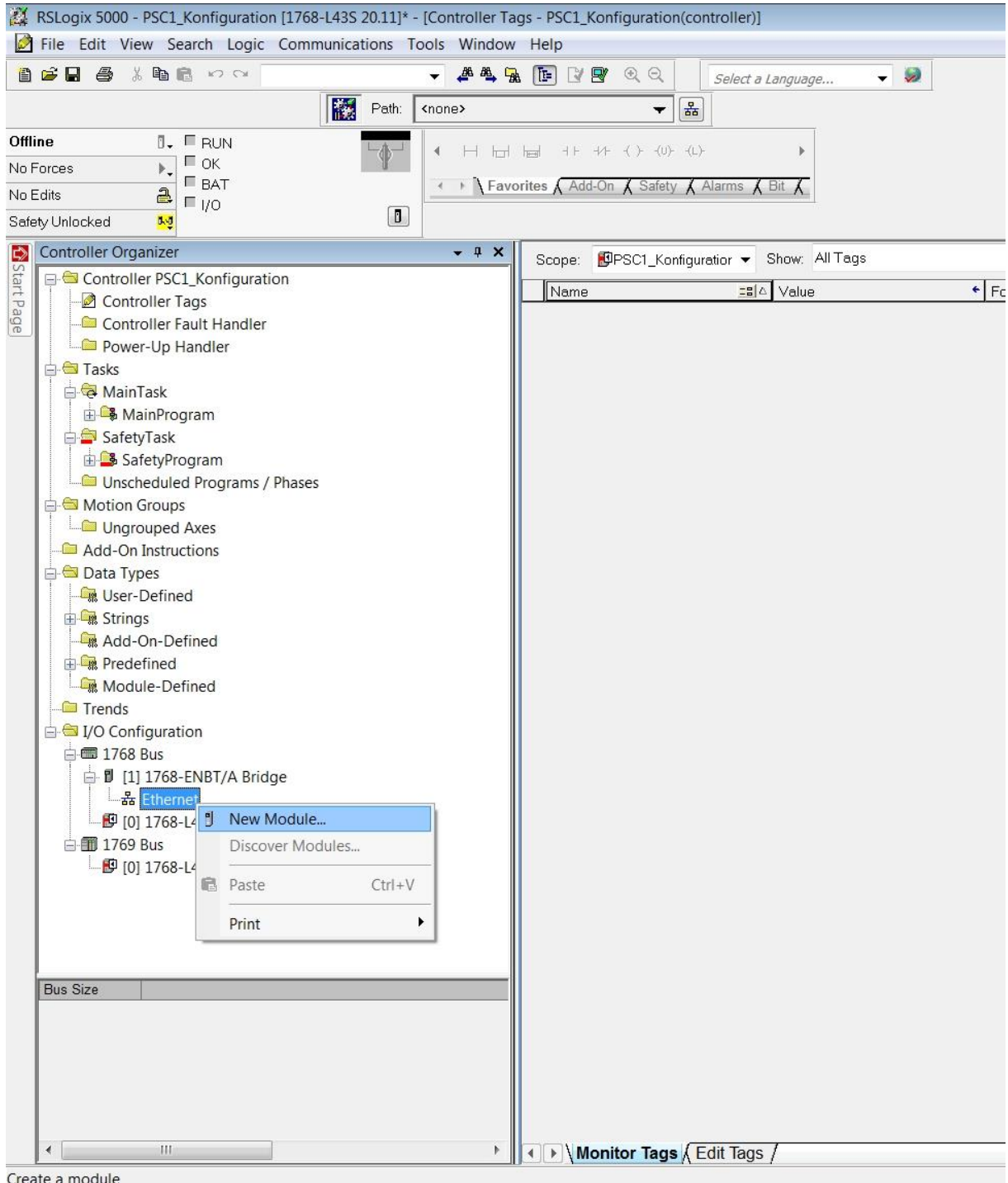

Create a module

Select PSC1-C-xxx-FB1-EIP in the device catalogue and click on "Create".

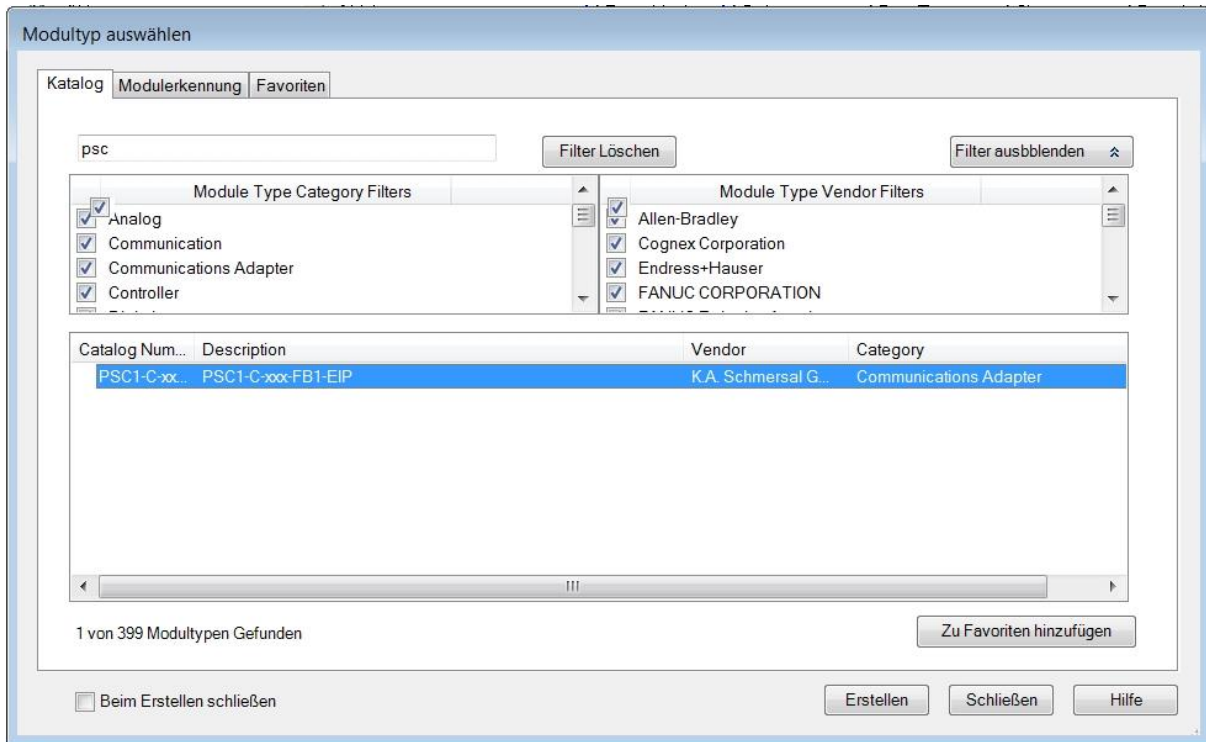

Then enter the IP address of the slave. Afterwards click on "Change" to set the communication area of the slave.

The Rockwell Automation BOOTP-DHCP tool can be used to assign the IP address (for more information see 12.2 Assigning IP addresses with the BOOTP-DHCP tool)

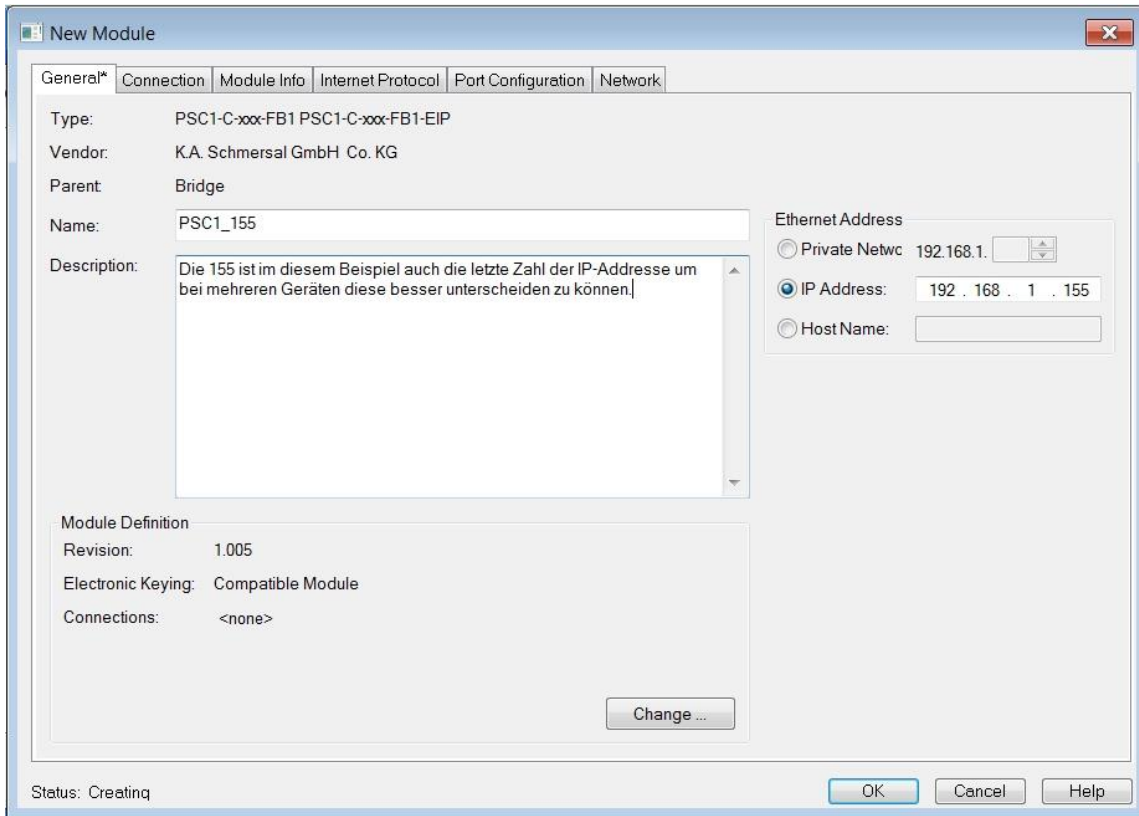

Select "Exclusive Owner" and click "OK".

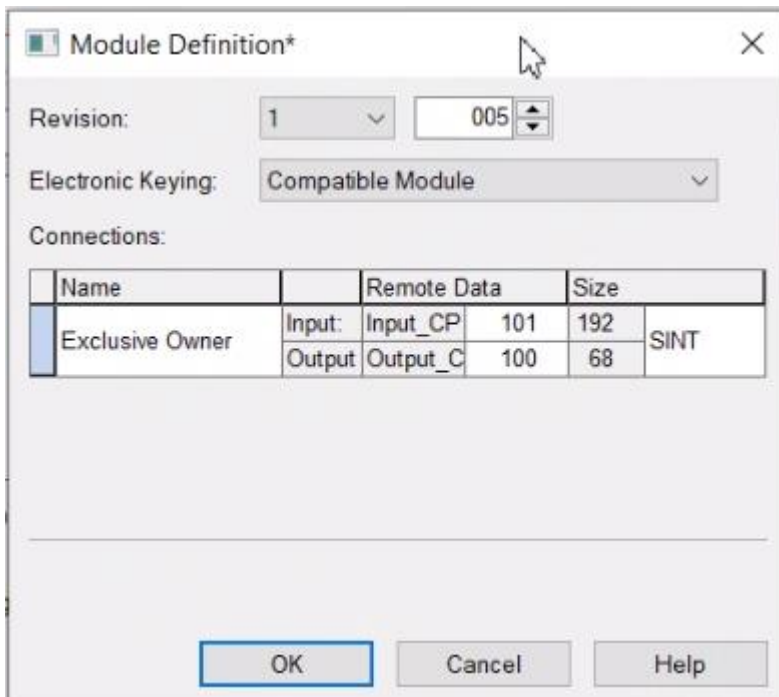

If necessary, click "Yes" to confirm your selection.

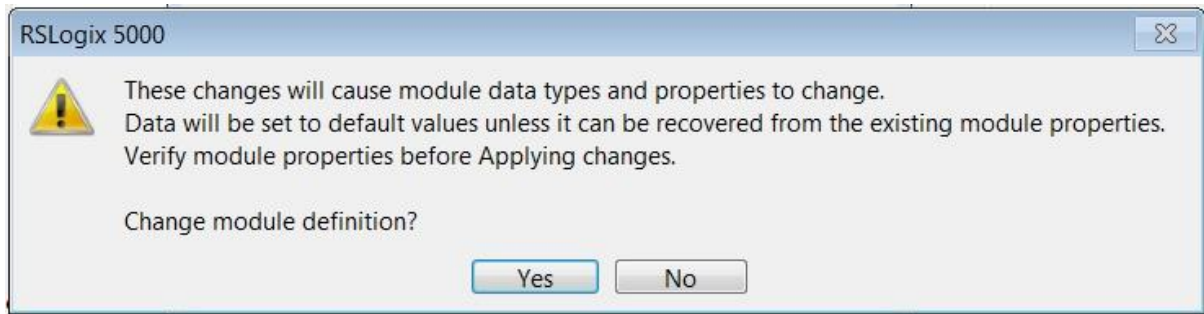

12.1.4 Setting up an online connection

Transfer your project by selecting "Communications" => "Go Online" in the menu.

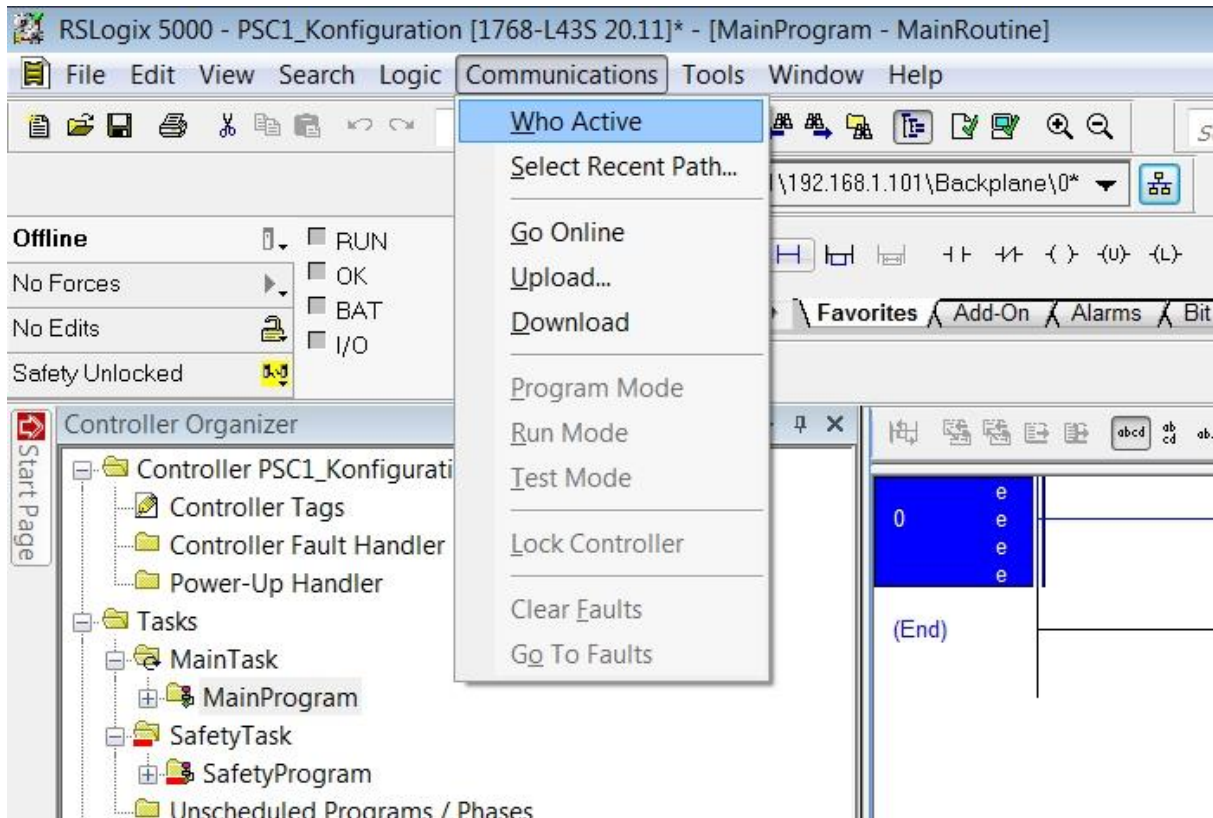

RSLogix5000 compares the online and offline projects. Confirm the data transfer with "Download".

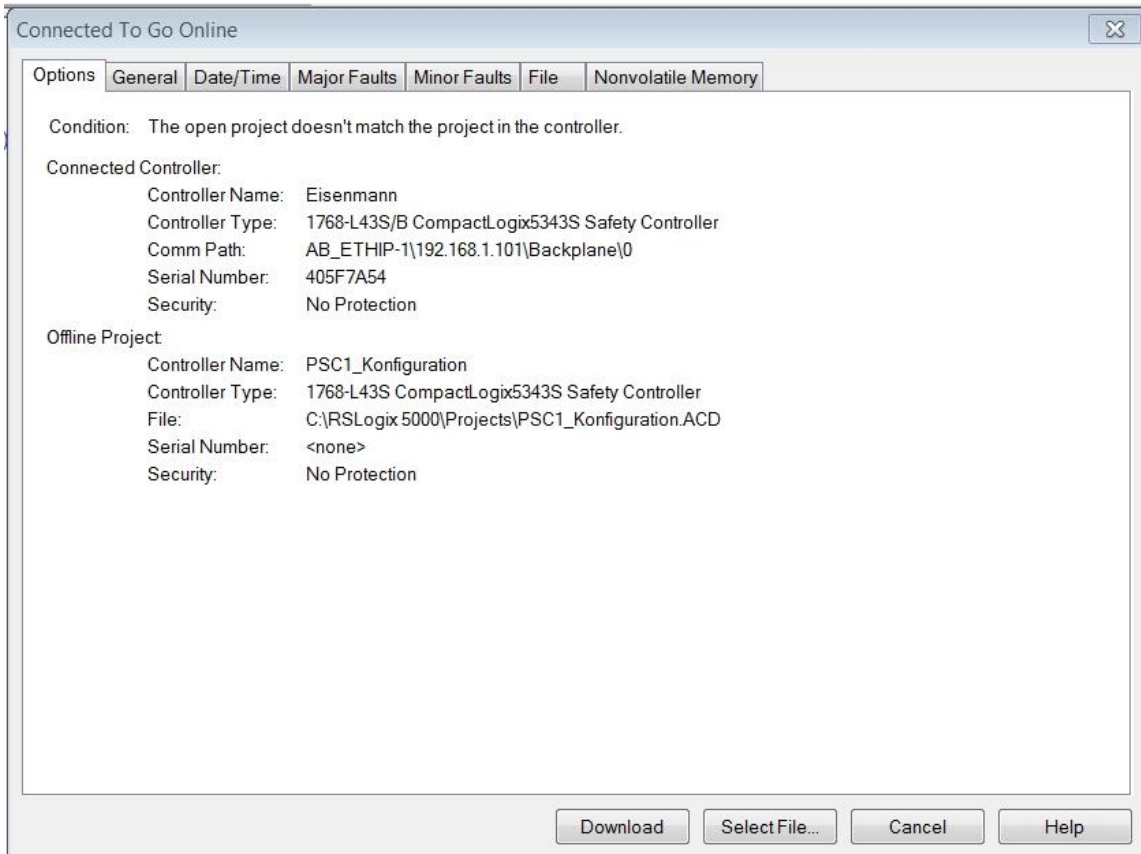

If necessary, also confirm the following warning with "Download".

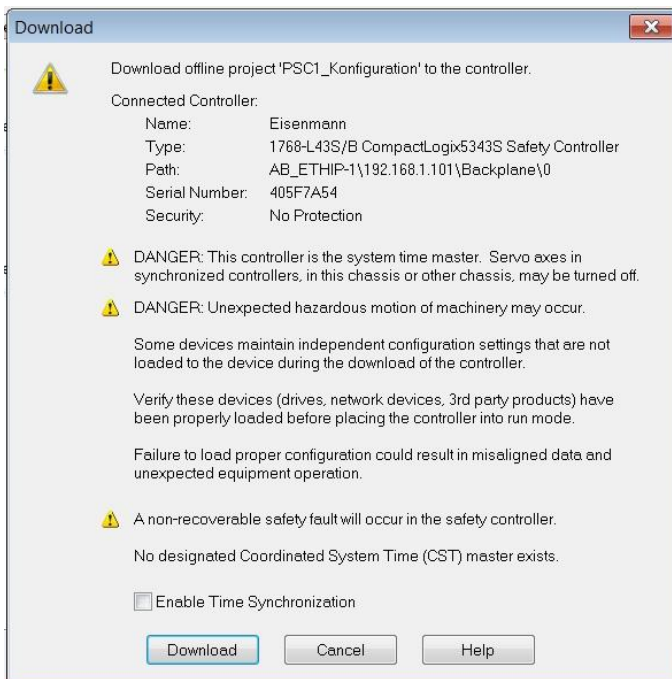

Signal states can be observed in the "Controller Tags" dialogue.

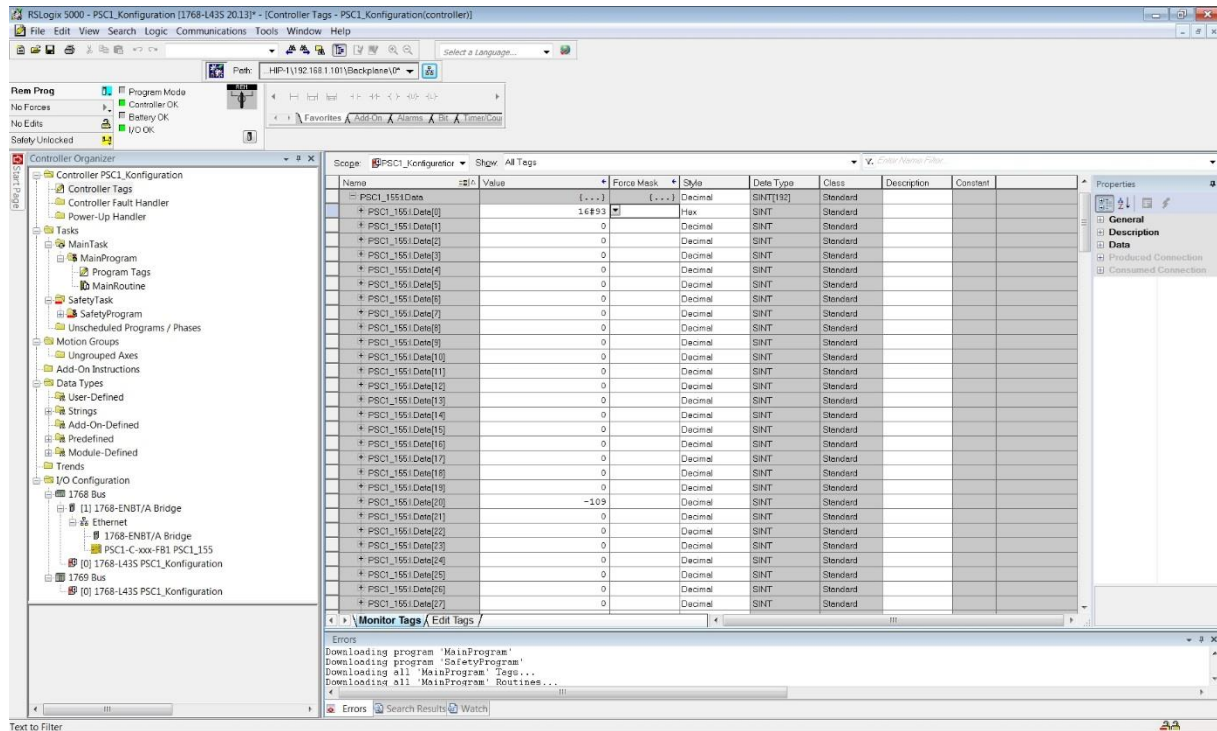

12.1.5 Examples of non-safe data transmission

In the following example, the switching state of the button "Confirm Button 1" is written to SafePLC2 in bit 0 and can be read in byte 5 (bit 0) of the configuration tool (RSLogix5000).

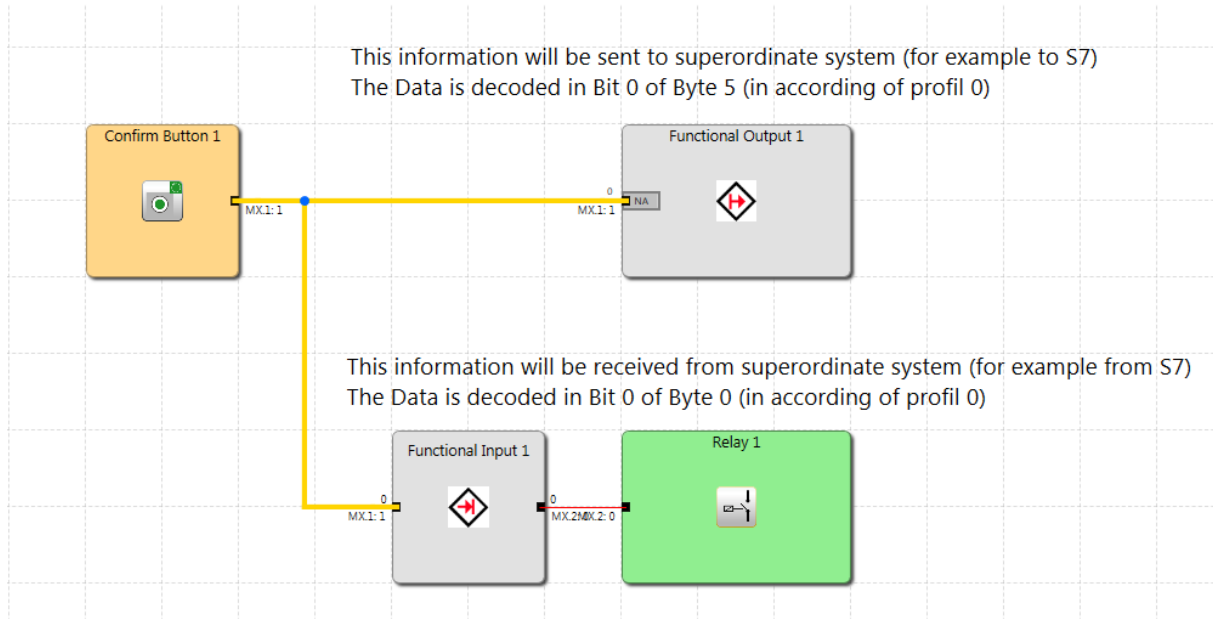

In addition, up to 32 non-safe functional inputs are available on the PSC1, via which digital information can be received from the higher-level standard controller. In the "SafePLC2" function diagram, these inputs must always be AND-linked to a safe input and can then be reused as required.

In the following example, the functional output (Byte0, Bit 0) is written in the higher-level standard control and AND-linked to a safe input in PSC1 (Confirm Button 1). Both have a high signal, relay 1 is activated.

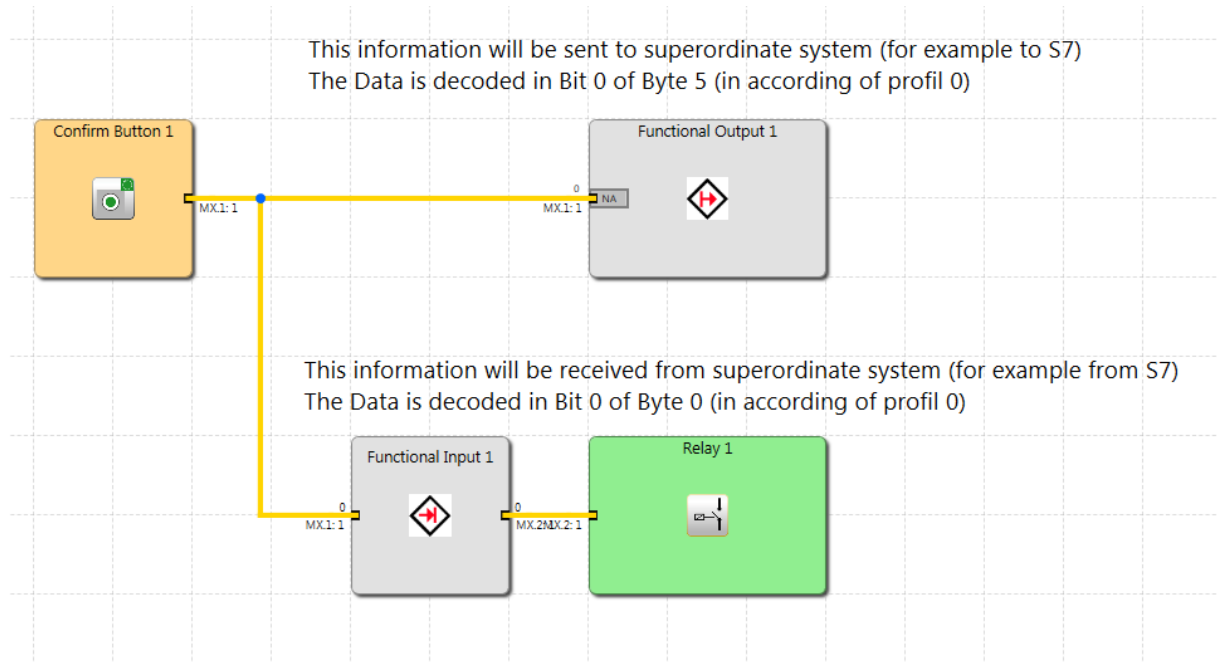

In the following example, the functional output (Byte0, Bit 0) is written in the higher-level standard control and AND-linked to a safe input in PSC1 (Confirm Button 1). "Confirm Button 1" has a low signal, the functional output from the standard control has a high signal, Relay 1 is not activated.

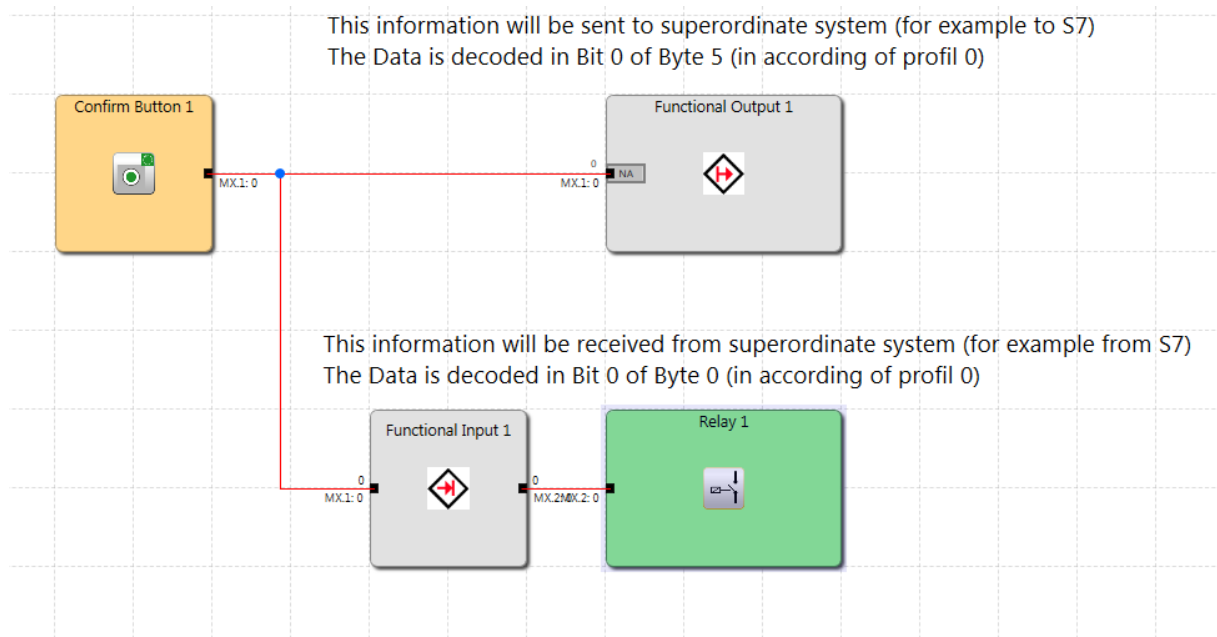

12.2 Assigning IP addresses with the BOOTP-DHCP tool

Start the "BOOTP-DHCP Tool" and select "Tools" => "Network Settings".

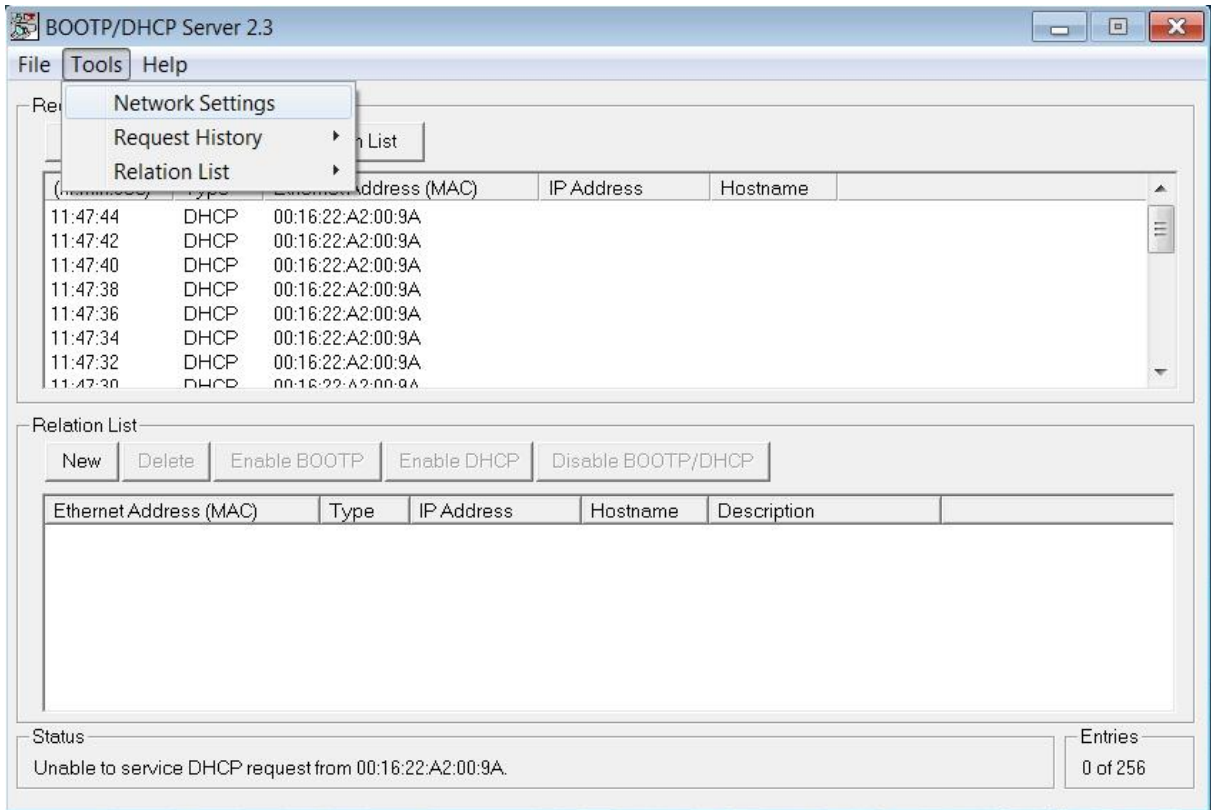

Enter the "Subnet Mask" and the IP address of the gateway. Confirm your entries with "OK".

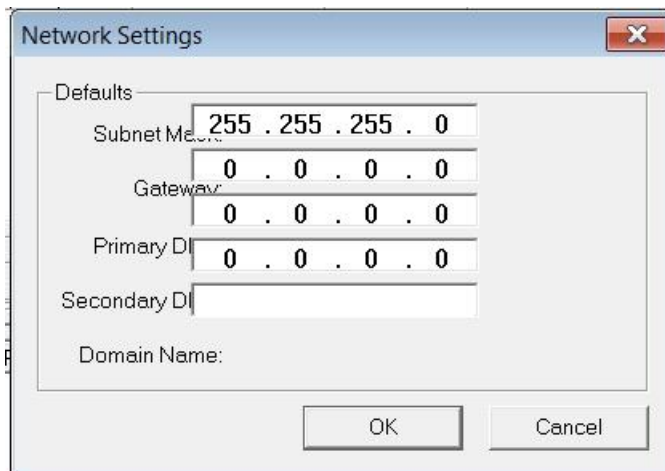

In the "Request History" select the desired slave and click on "Add to Relation List"
(Alternatively you can double-click on the desired slave).
Enter the IP address of the slave and confirm your entries with "OK".

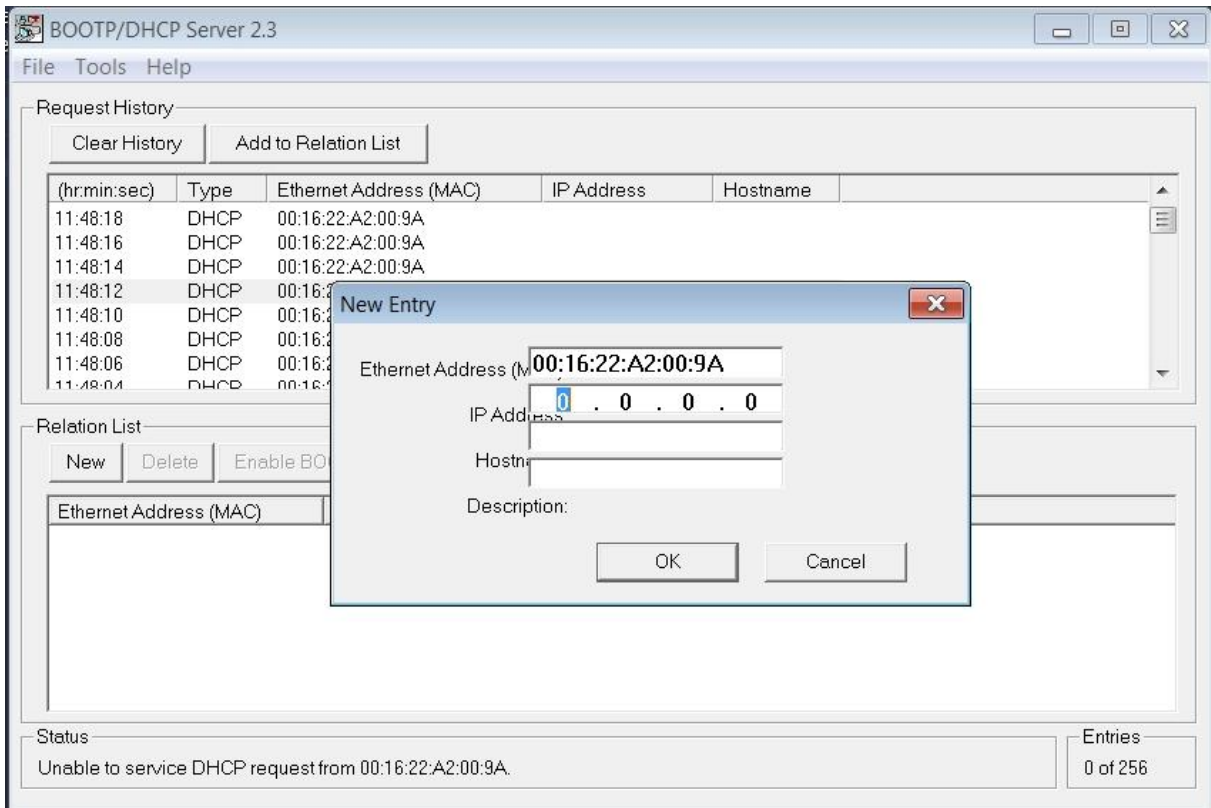

The slave is now displayed with the corresponding IP address in the "Relation List". To assign the address permanently, click on "Disable BOOTP/DHCP".

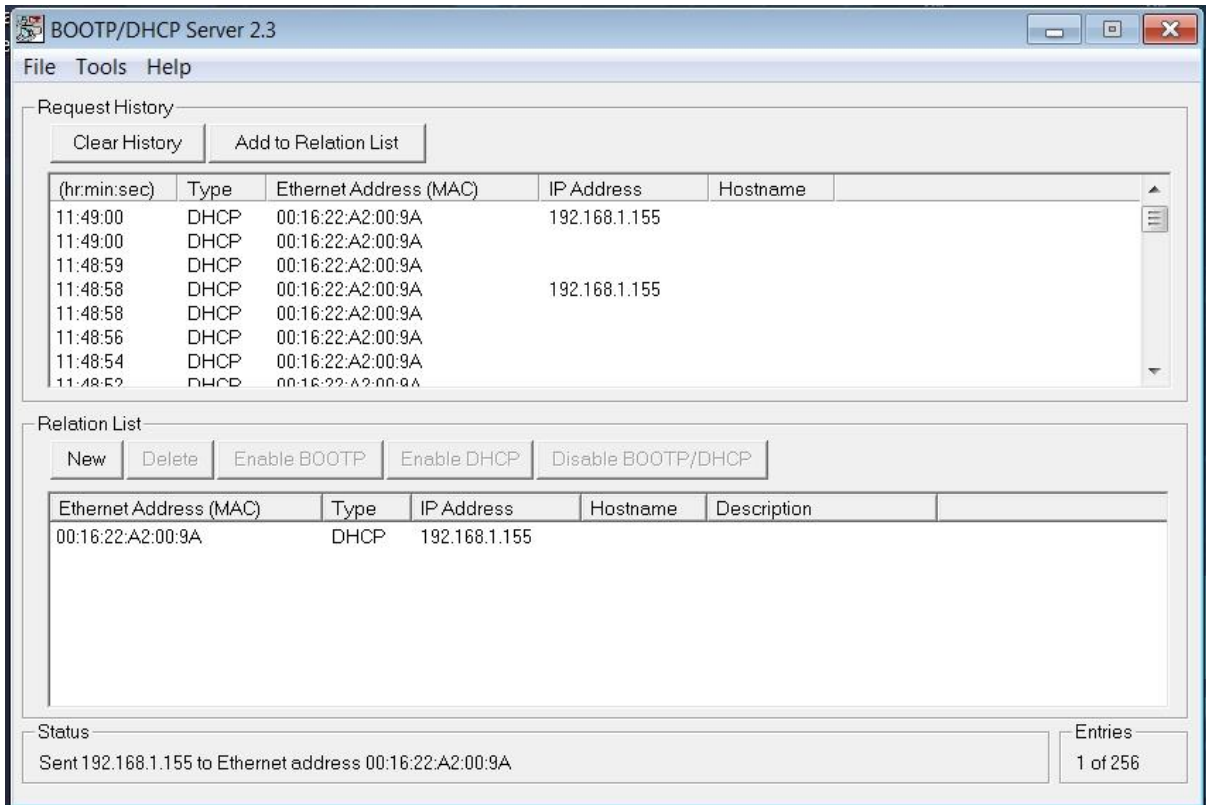

Request History

Clear History Add to Relation List

(hr:min:sec)	Type	Ethernet Address (MAC)	IP Address	Hostname
11:49:00	DHCP	00:16:22:A2:00:9A	192.168.1.155	
11:49:00	DHCP	00:16:22:A2:00:9A		
11:48:59	DHCP	00:16:22:A2:00:9A		
11:48:58	DHCP	00:16:22:A2:00:9A	192.168.1.155	
11:48:58	DHCP	00:16:22:A2:00:9A		
11:48:56	DHCP	00:16:22:A2:00:9A		
11:48:54	DHCP	00:16:22:A2:00:9A		
11:48:52	DHCP	00:16:22:A2:00:9A		

Relation List

New Delete Enable BOOTP Enable DHCP Disable BOOTP/DHCP

Ethernet Address (MAC)	Type	IP Address	Hostname	Description
00:16:22:A2:00:9A	DHCP	192.168.1.155		

Status

Sent 192.168.1.155 to Ethernet address 00:16:22:A2:00:9A

Entries 1 of 256

12.3 Assigning IP addresses using the IP administrator

Start the tool via the IP-Administrator button in the Connection tab.

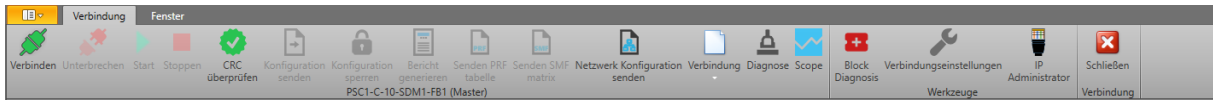

executing IP-Administrator via the connection tab

At startup, the system checks whether a WinPcap driver is installed on the computer. WinPcap is also used by tools such as Wireshark and is used to receive IP packets for network analysis. As WinPcap is not necessary for Ethernet/IP you may ignore the message.

Note:

The compatibility mode of Npcap (<https://nmap.org/npcap/>) must not be used. However, a parallel installation can exist.

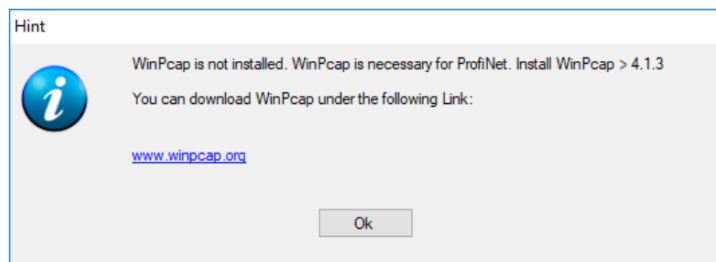

missing WinPcap driver message

First select the network card which is connected to the respective PSC1.

Note: Only network cards are listed that are connected to an active network. The IP address of the selected network card must be in the same IP address range (subnet mask) as the PSC1.

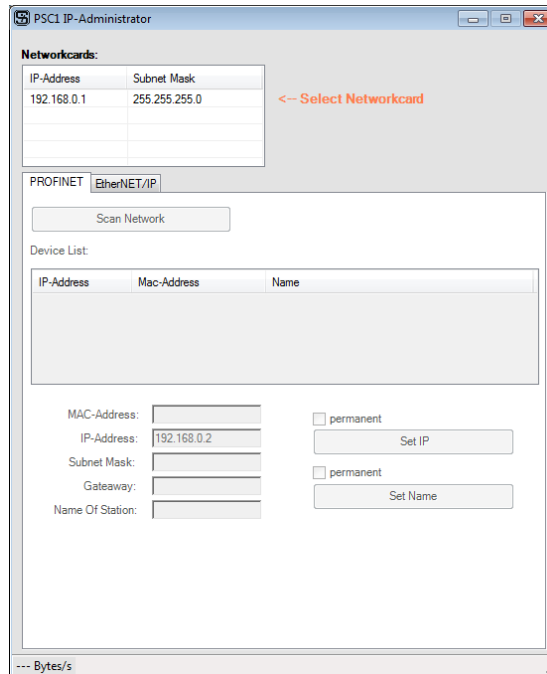

Select network card

The *Scan Network* button runs the search. All devices with activated DHCP, but without assigned IP address, are then listed in the *DHCP Requests* list. The desired IP address can now be entered in the *IP-Address* text field and is transferred via DHCP to the connected PSC1 via the *Set IP Address via DHCP* button. This process may take a moment.

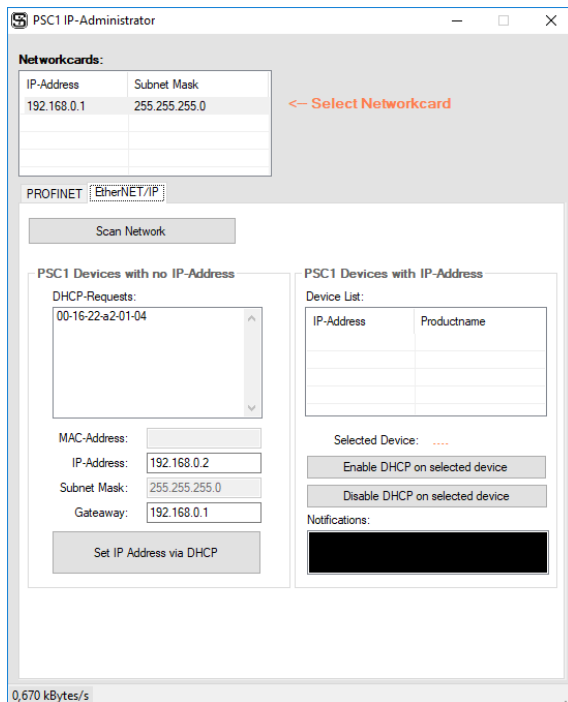

PSC1 without assigned IP-Address and DHCP activated

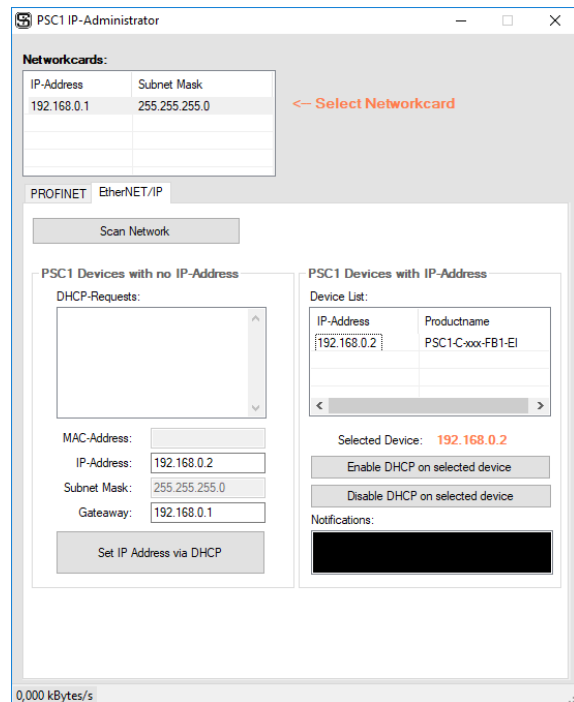

PSC1 with assigned IP-Address

The device now appears automatically in the *Device List*. All PSC1 devices already having an IP address assigned are listed here.

Note: The MAC-Address printed on the devices represents the MAC-Address of the SDDC connection ports. The MAC-Address of the fieldbus ports is derived following the example:

00:16:22:**22**:12:34

00:16:22:**A2**:12:34

& 80h

If the IP address is to be permanently assigned, the DHCP service must be deactivated via *Disable DHCP on selected device*. Message about the successful deactivation is displayed in the Notifications area.

Changing an IP address

To assign a new IP address to a PSC1 device, the device first must be selected in the *Device List* and then via *Enable DHCP on selected device* DHCP must be activated for this device. After the message about successful execution a power-on reset is recommended. Afterwards the device is accessible via DHCP and can be found in the *DHCP Requests* list.

Please then follow the procedure described above.

12.4 Explicit Messaging

Reading/Writing of fieldbus data is also possible via **Explicit Messaging** objects.

There are two different Assembly Objects available:

Instance 64h(100d) / (PLC -> PSC1)

4 Byte Functional Inputs and 64 Byte SD Bus request

Instance 65h(101d) / (PLC <- PSC1)

128 Byte Functional Outputs and 64 Byte SD Bus response

With the services

Get_Attribute_Single (0Eh)

Set_Attribute_Single (10h)

the data (attribute 03h) and the data length (Attribut 04h) can be read or written.

Byte	Bit	"Run" mode (2, 3, 4)	Error case (A, F)
Byte 0	0...3	PSC1 mode 1, 2, 3, 4, 5, 6 = Fatal error, 7 = Alarm	
	4	0x1 (always 1)	
	5..7	Alive counter (3 Bit)	
Byte 1	0...7	Logic data (Bit ID: 48..55)	
Byte 2	0...7	Logic data (Bit ID: 40..47)	
Byte 3	0...7	Logic data (Bit ID: 32..39)	
Byte 4	0...7	Logic data (Bit ID: 8..15)	
Byte 5	0...7	Logic data (Bit ID: 0...7)	
Byte 6	0..6	Logic data (Bit ID:24.. 30)	Error code: high Byte
	7	"0"	"1"
Byte 7	0..7	Logic data (Bit ID: 16..23)	Error code: low Byte

Table 10: PSC1-C-10-x-FB1/2 logic data

13 Commissioning and configuration EtherCAT in SafePLC2 and TwinCat 3

EtherCAT is available for all PSC1 base devices with the "-FB1" option. The "-FB1" option is always permanently integrated in the base device and represents the gateway from the CAN-based backplane bus of the PSC1 series to EtherCAT. It enables the user to exchange data bidirectionally via EtherCAT with a higher-level controller.

In the properties of the PSC1 base device, the:

- **Local Network** - the property **fieldbus** is activated,

and in the **fieldbus properties (Fieldbus)** under:

- **Type - ETHERCAT**

and under

- **Network Patterns (network prototype) - non-safe** for non-safe data transmission

must be selected.

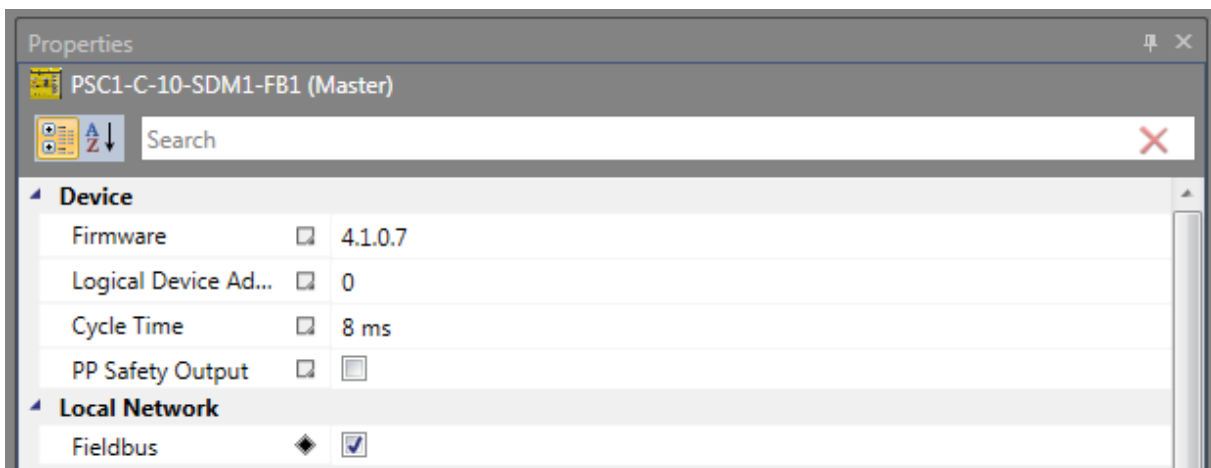

Figure 19: Properties PSC1 basic device - EtherCAT

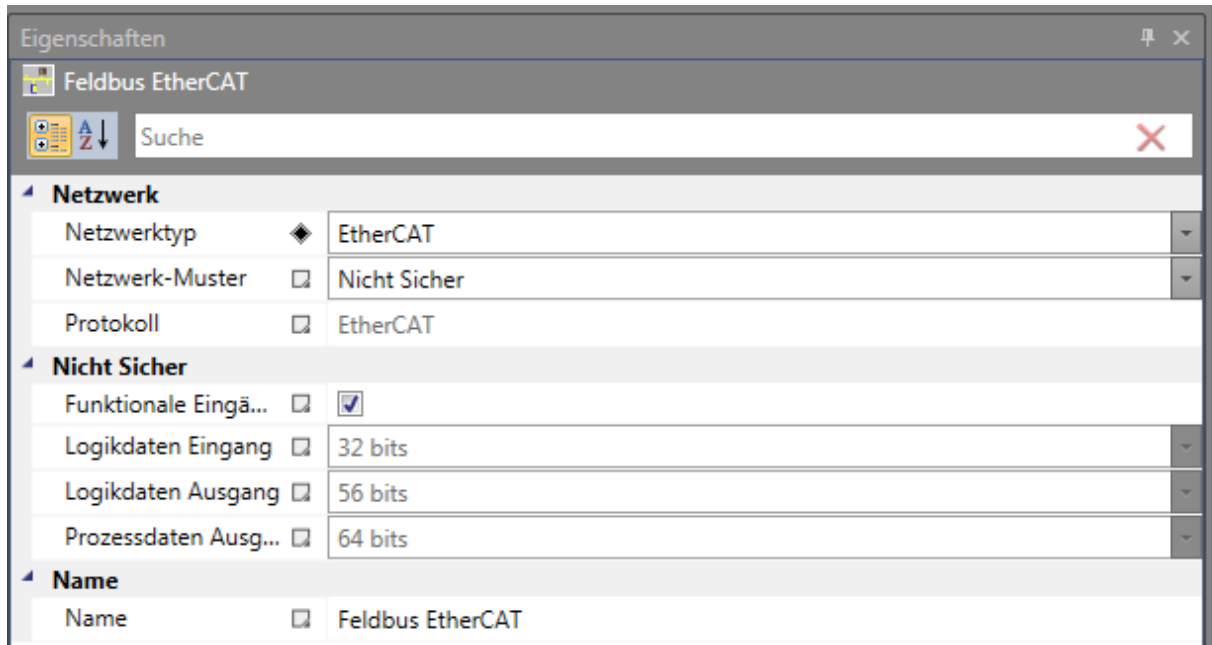
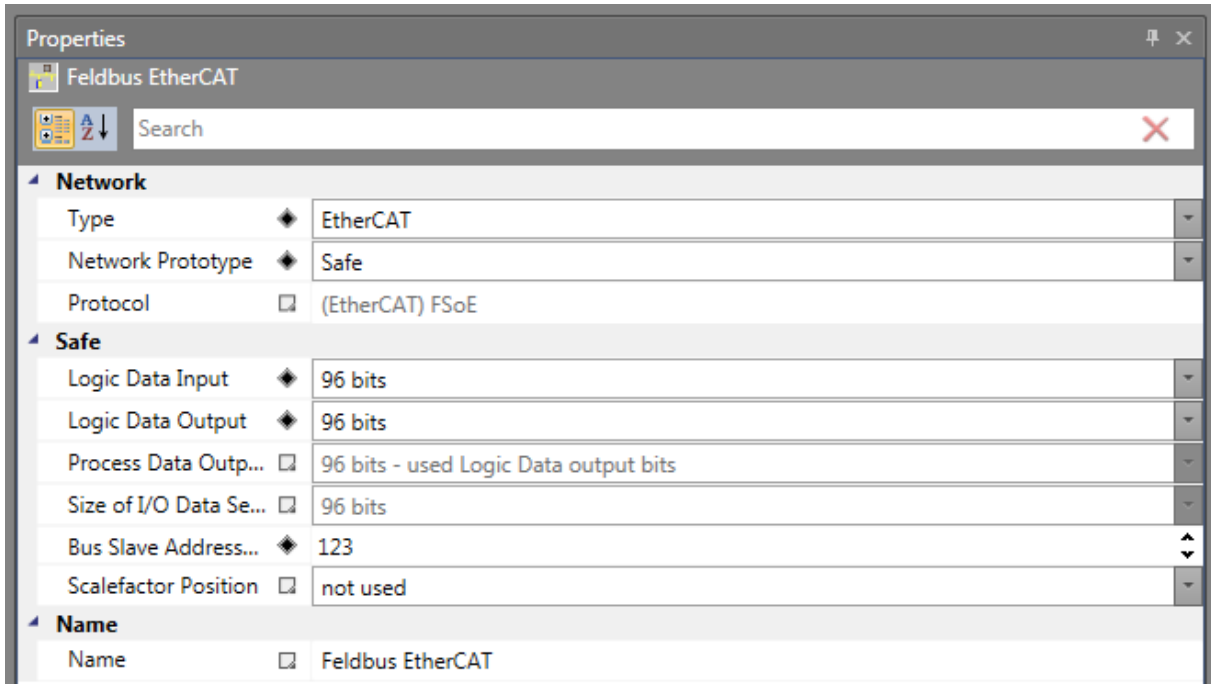
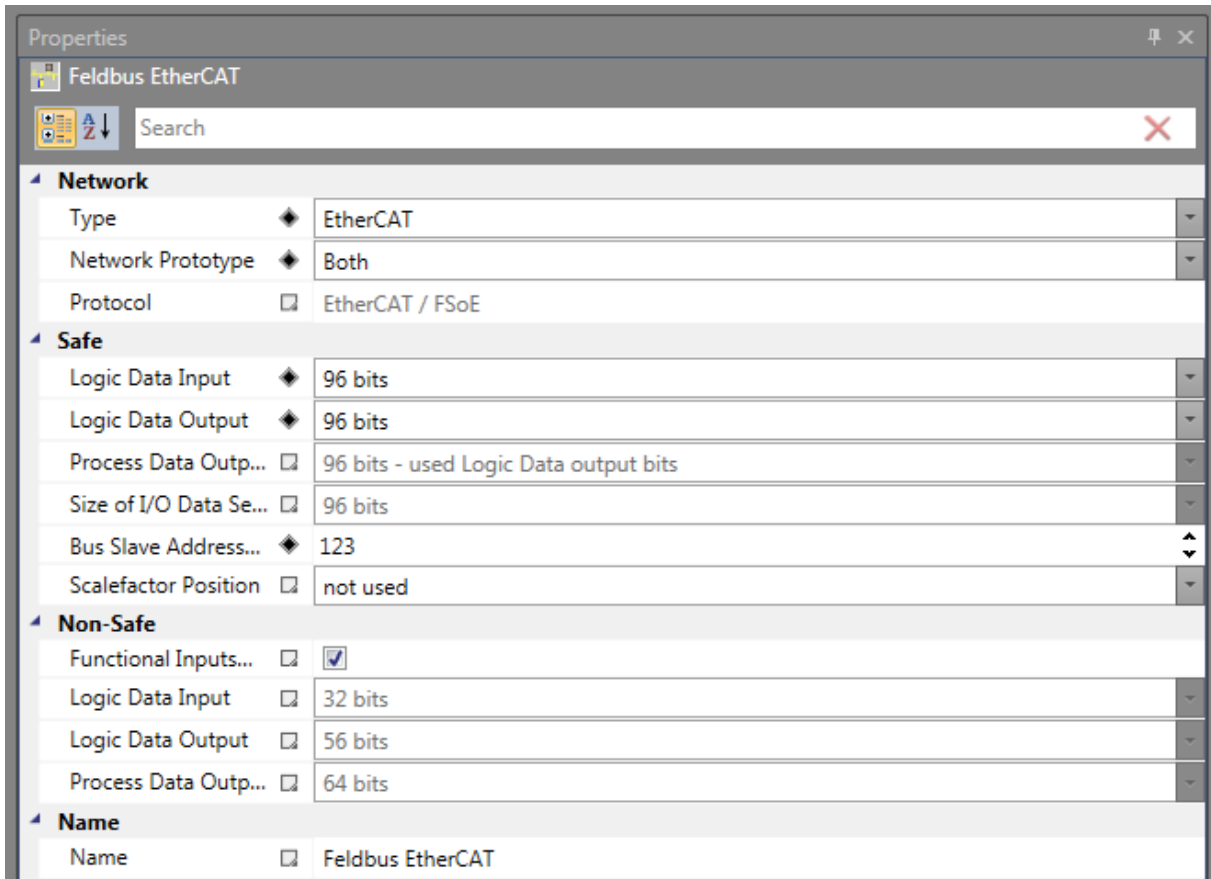

Figure 20: Properties fieldbus (Feldbus EtherCAT) - non-safe

Parametrisation for safe data transmission (FSoE)



Parametrisation for non-safe and safe data transmission (FSoE)



The functional inputs and outputs must still be inserted in the "Functional scheme" and logically connected.

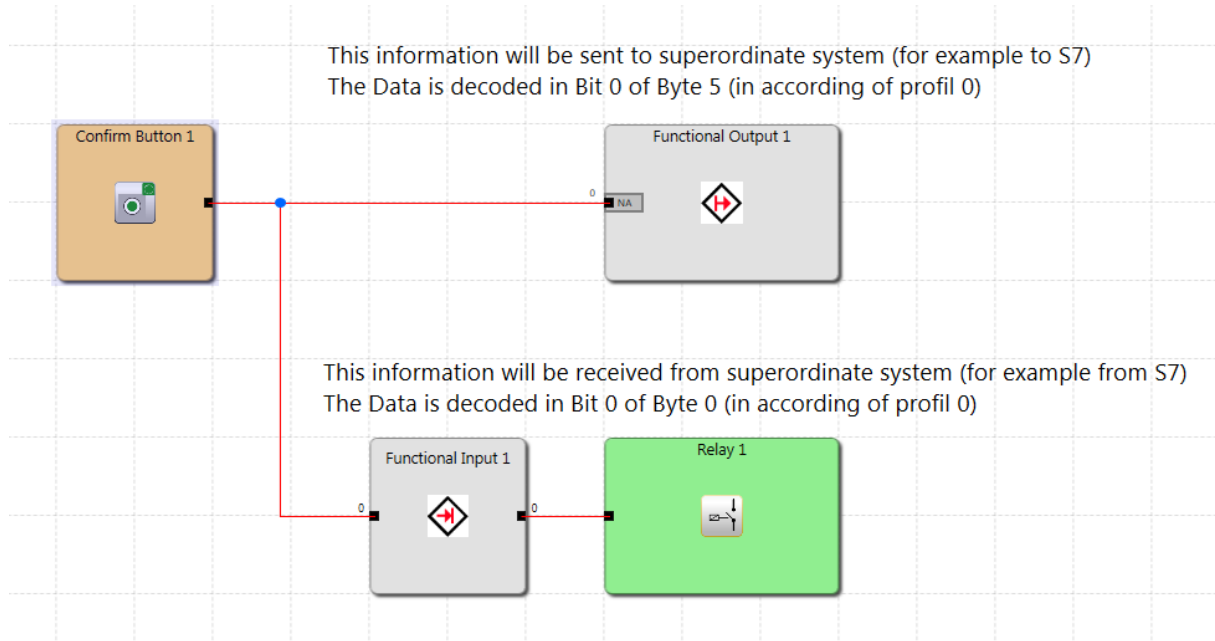

The project and the network configuration must be transferred:
"Click the "Device Interface" icon



Click the "Connect" icon in the new dialogue.

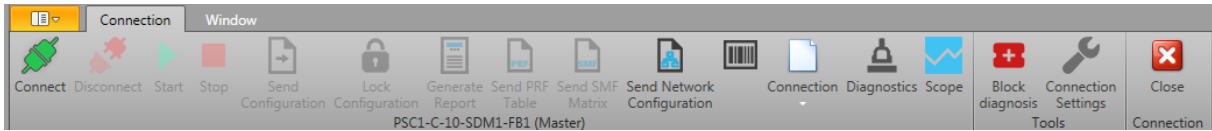

The successful connection to PSC1 is displayed in the following dialogue ("Connect icon" faded out / "Disconnect icon" faded in).

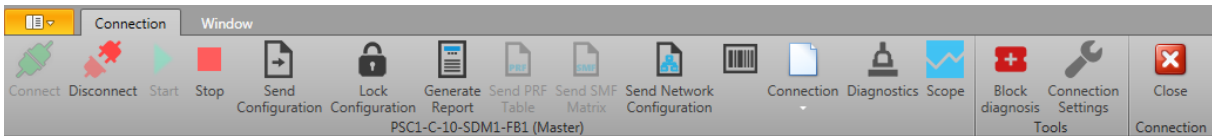

Now the network configuration and the source code can be transferred.

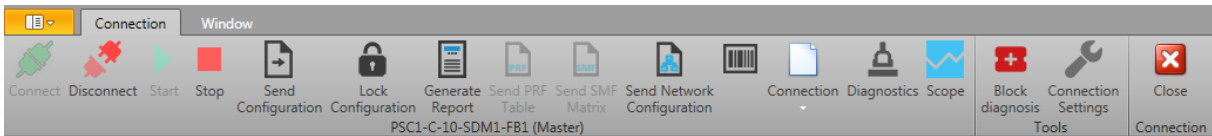

The transfer status (progress bar) is displayed in the lower information bar.

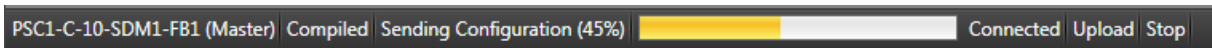

After transmission, the PSC1 may have to be restarted ("Green arrow icon").

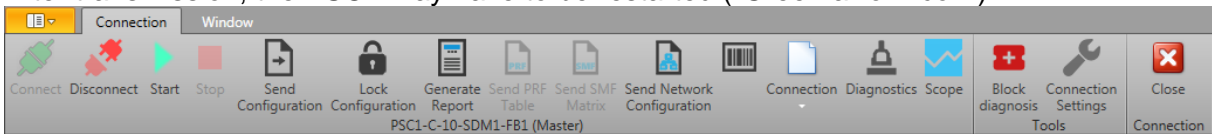

13.1 Parameter configuration

The parameters are set using the "TwinCAT 3" program from Beckhoff Automation GmbH & Co. KG

13.1.1 Create project and search for target system

Before you can work with the devices, you must connect your local computer to the target device.

Then you can search for devices by IP address or host name.

The local PC and the target devices must be on the same network or connected directly via an Ethernet cable.

All devices can be searched for and subsequently configured in TwinCAT 3 in this way.

Prerequisites for this step:

- TwinCAT 3 must be in Config mode
- IP address or host name of the device known

Search for the devices as follows:

- Click in the menu on File => New => Project and create a new "TwinCAT XAE project".
- Click on "SYSTEM" on the left side of the tree view and then on "Choose Target".

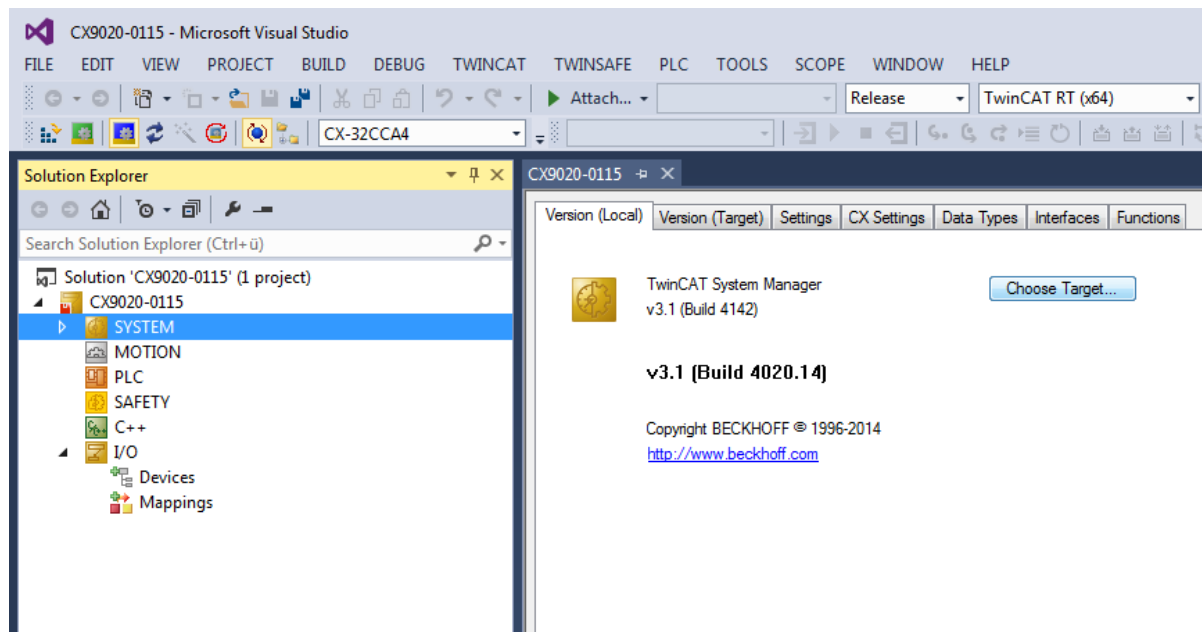

Click on "Search (Ethernet)".

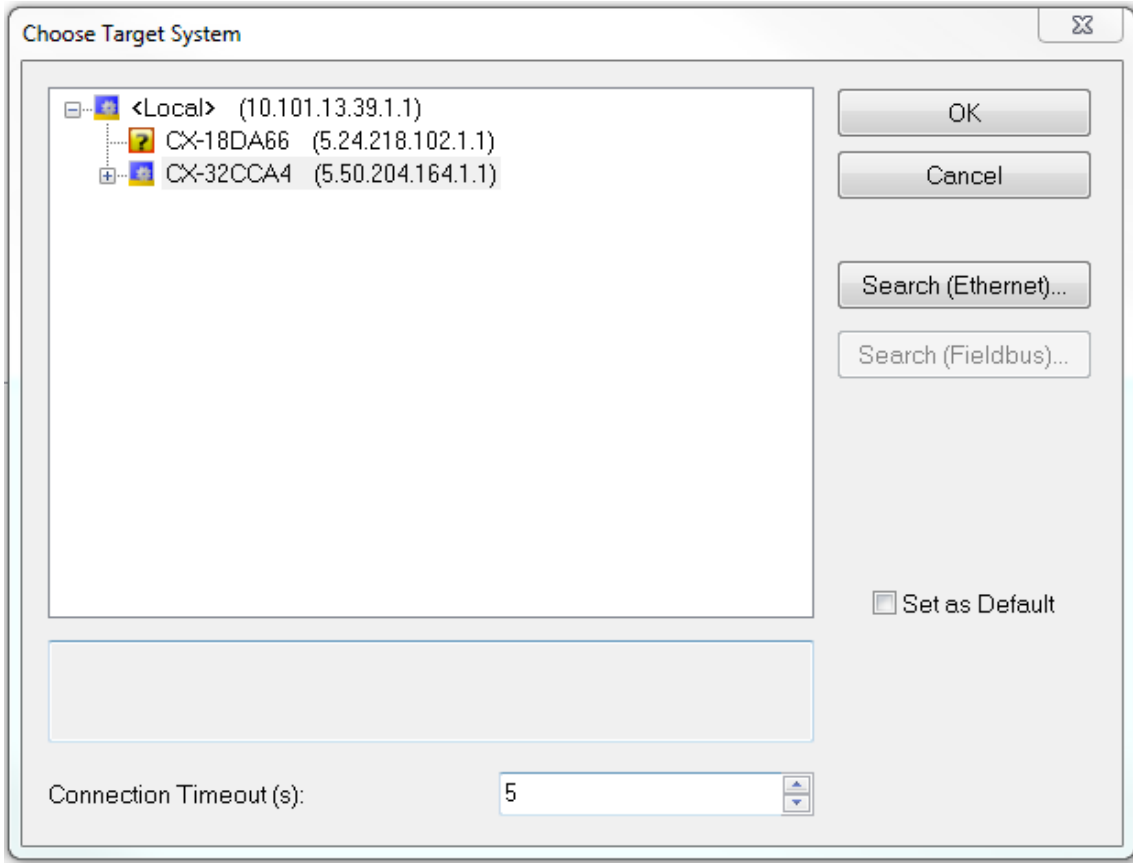

Click on "Broadcast Search".

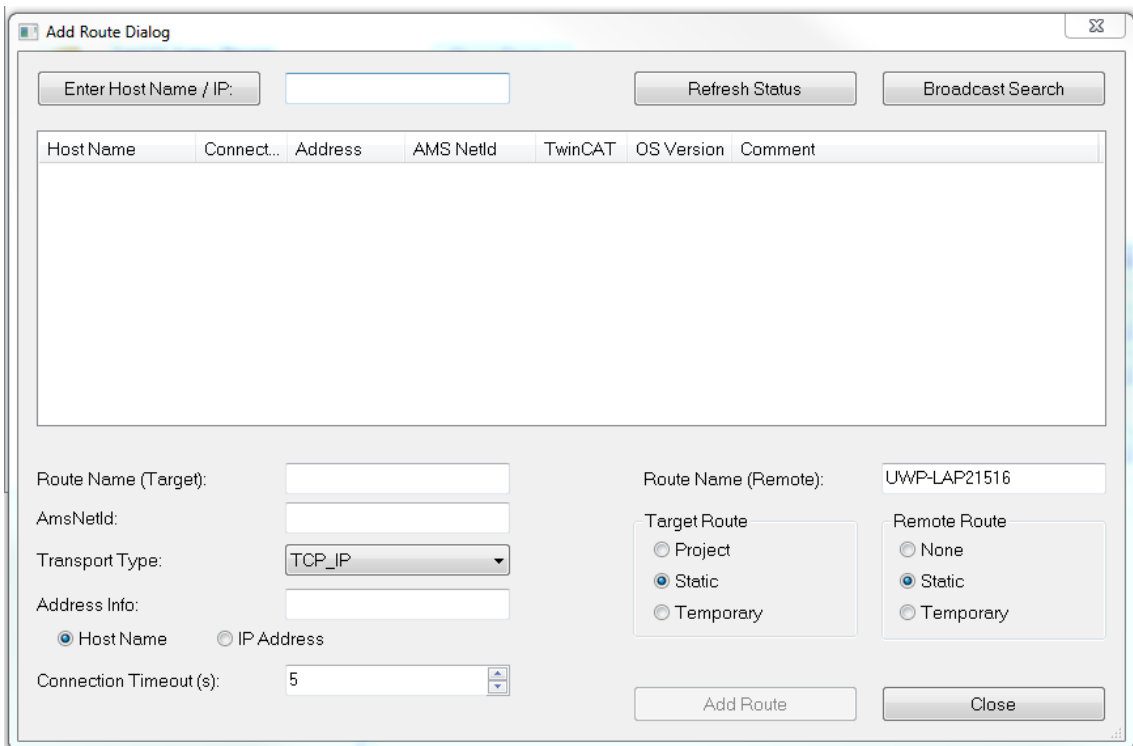

Select the device found and then click on "Add Route".

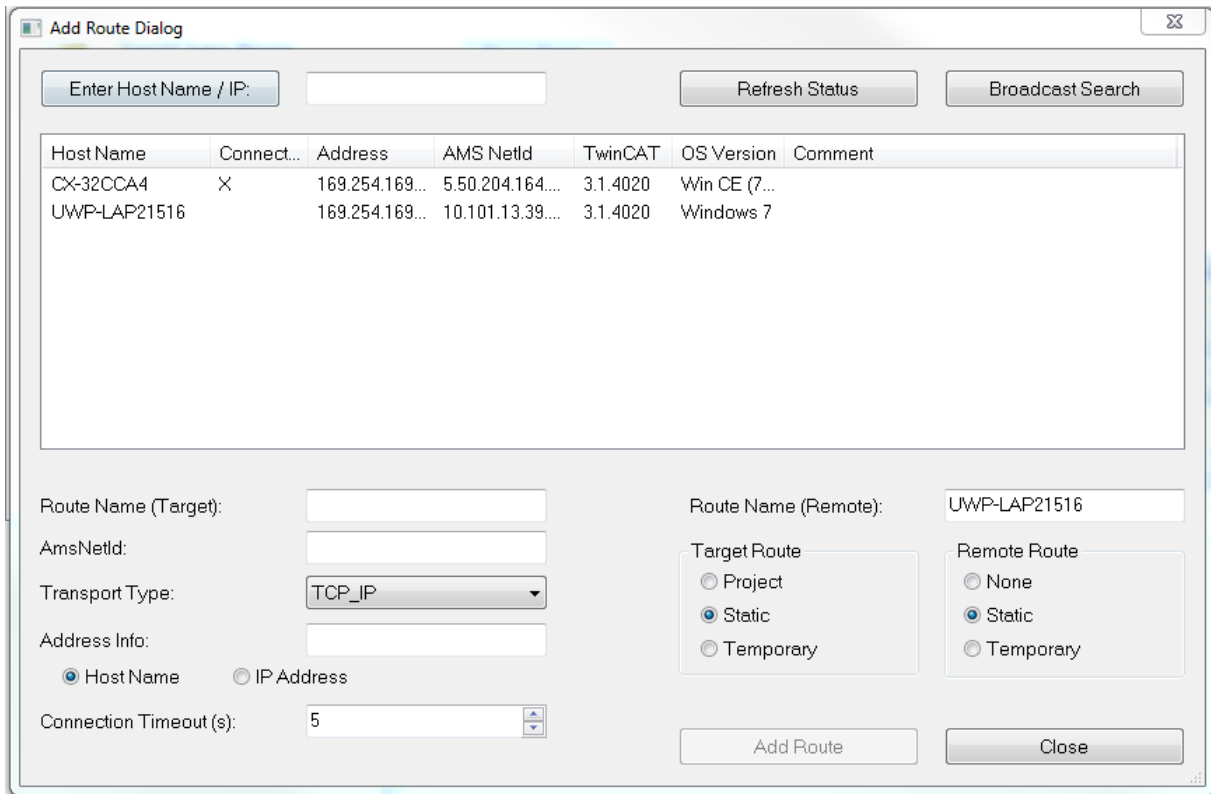

Enter the user name in the "User Name" field and the password for the user in the "Password" field.

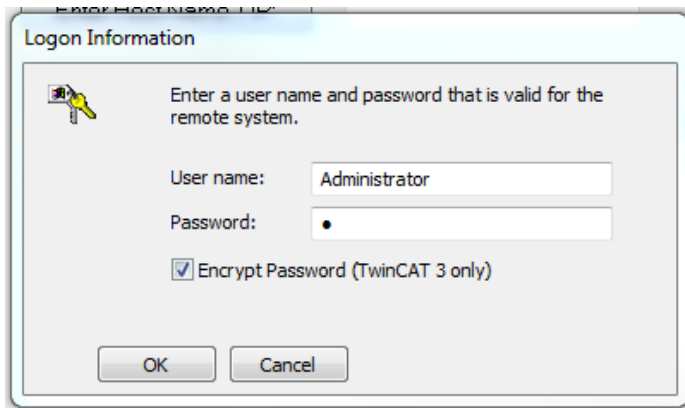

13.1.2 Find connected I/O devices

Import EtherCAT XML Device Description (ESI):

The files should always be unpacked completely into the ESI directory of the EtherCAT Master. The directory can be found in TwinCAT 3.x under "\TwinCAT\3.x\Config\Io\EtherCAT".

Activate in the upper navigation bar "Config Mode".

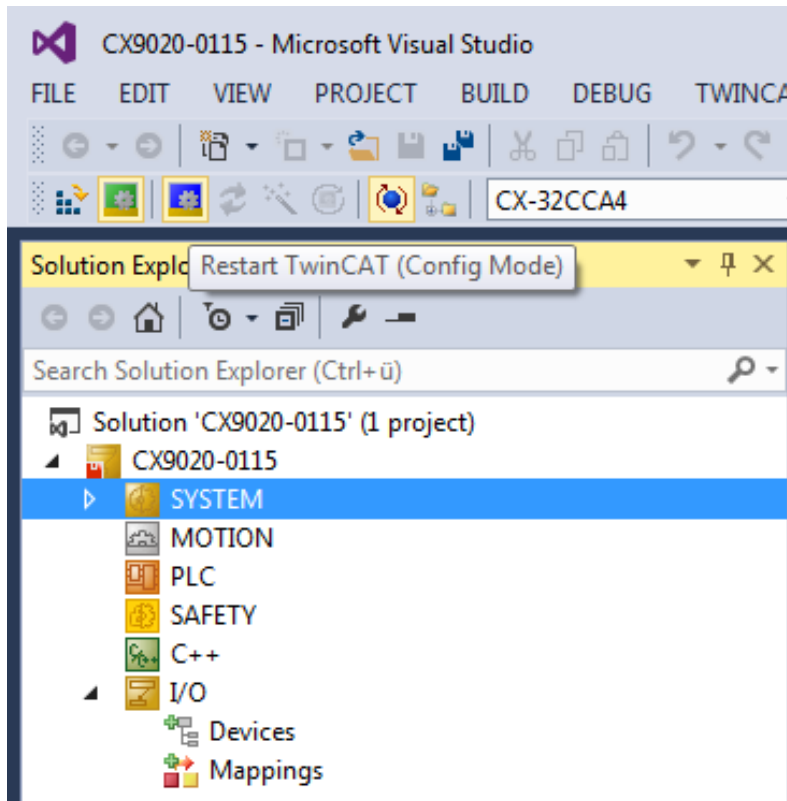

If necessary, confirm the mode switch.

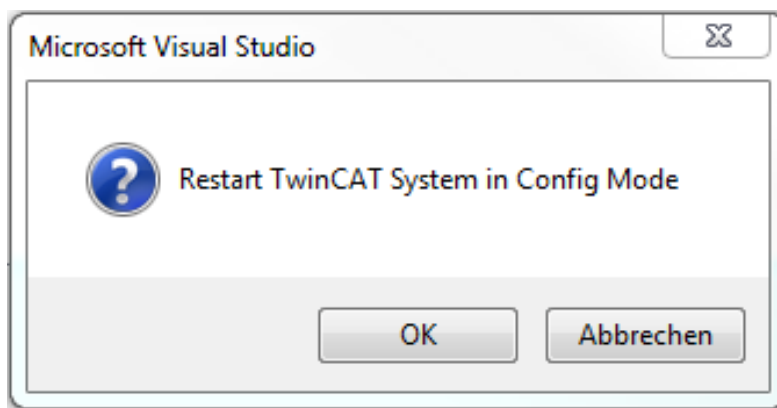

Right-click I/O Devices in the tree view on the left and "Scan" in the context menu.

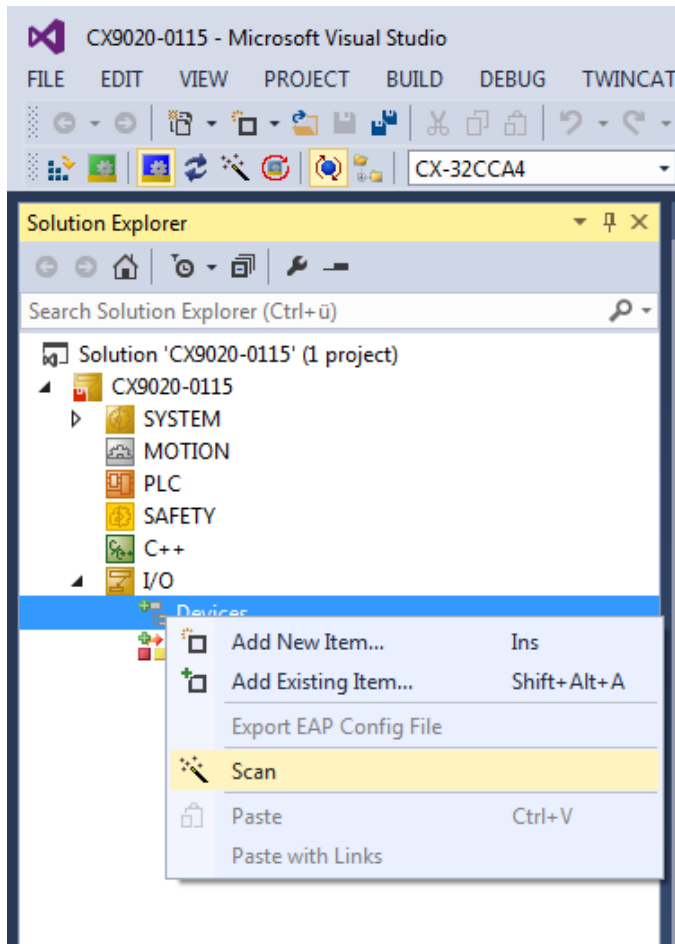

Select the devices you want to use and confirm the selection with "OK".
Only the devices that are actually present are available.

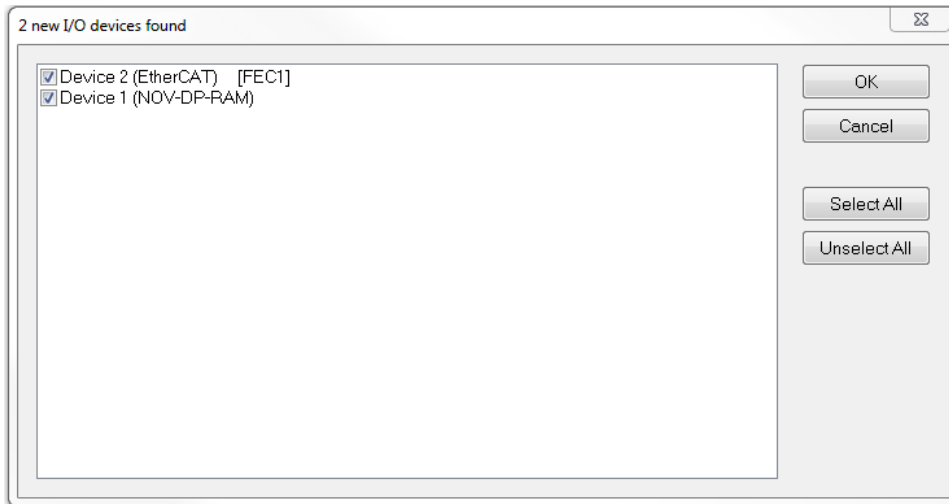

Confirm the query with Yes to search for "Boxes".

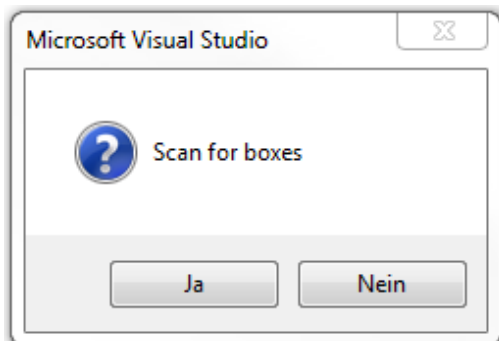

Confirm the request with "Yes" to activate "Free Run".

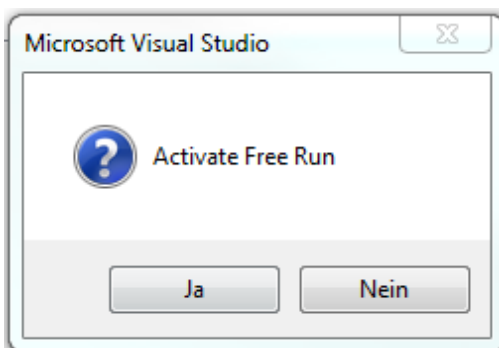

The PSC1 is displayed in the tree view as Box x (KAS ComX).

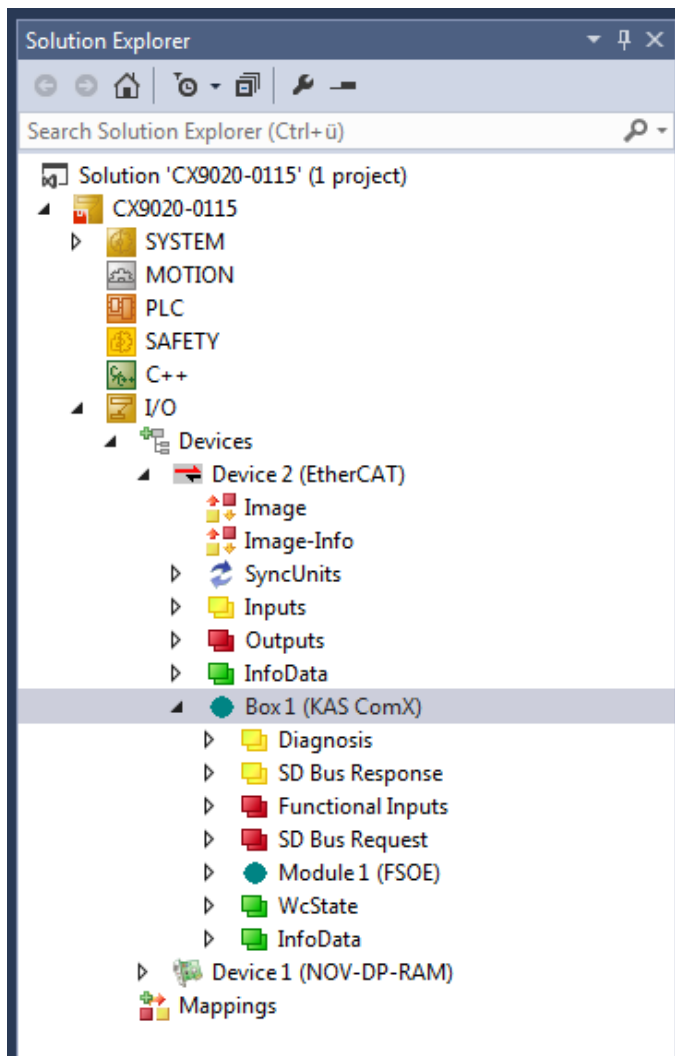

13.1.3 EoE

EoE (Ethernet over EtherCAT) tunnels standard Ethernet communication over EtherCAT without interfering with normal EtherCAT communication. The EoE mechanism allows to access the PSC1 in an EtherCAT environment via SafePLC2.

Depending on the system settings, the following error message may appear

```
✖ 1 06.12.2018 12:08:18 094 ms | 'Box 6 (KAS ComX)' (1005) 'IP': EoE init cmd type 2 failed with result 0x0001 - Unspecified error: 'eoe init'.
```

This is caused by missing entries for the EoE communication.

Click on the Ethercat Slave in the tree view, then select the 'Ethercat' tab and click on 'Advanced Settings'

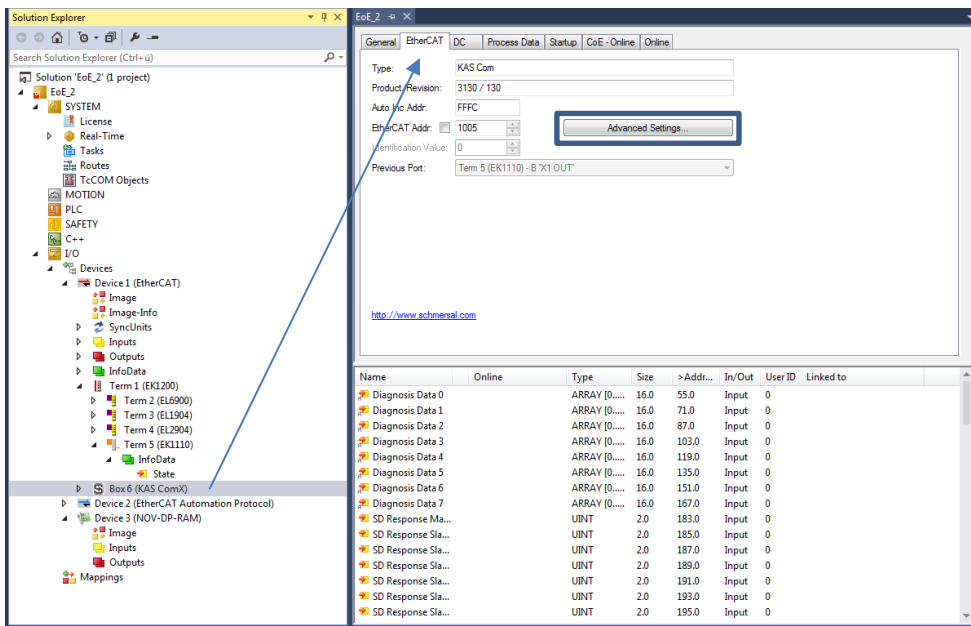

The settings for EoE then can be found under the entry 'Mailbox'.

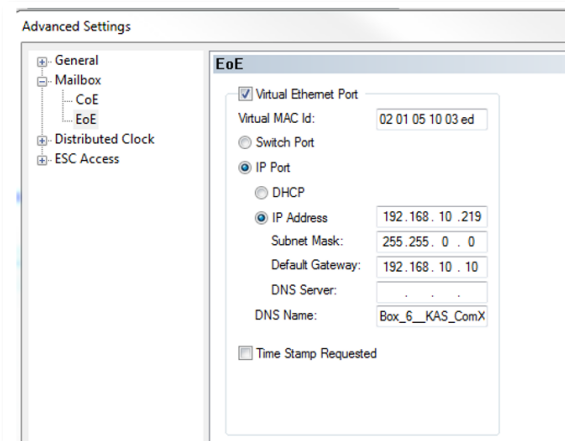

If TCP/IP communication is desired, enter the respective settings for your environment, i.e. either DHCP or enter an IP-address.

If EoE shall not be used, deactivate the 'Virtual Ethernet Port' selection

13.1.4 Examples of non-safe data transmission

In the following example, the switching state of the button "Confirm Button 1" is written to SafePLC2 in bit 0 and can be read in byte 5 (bit 0) of the configuration tool (TwinCAT 3).

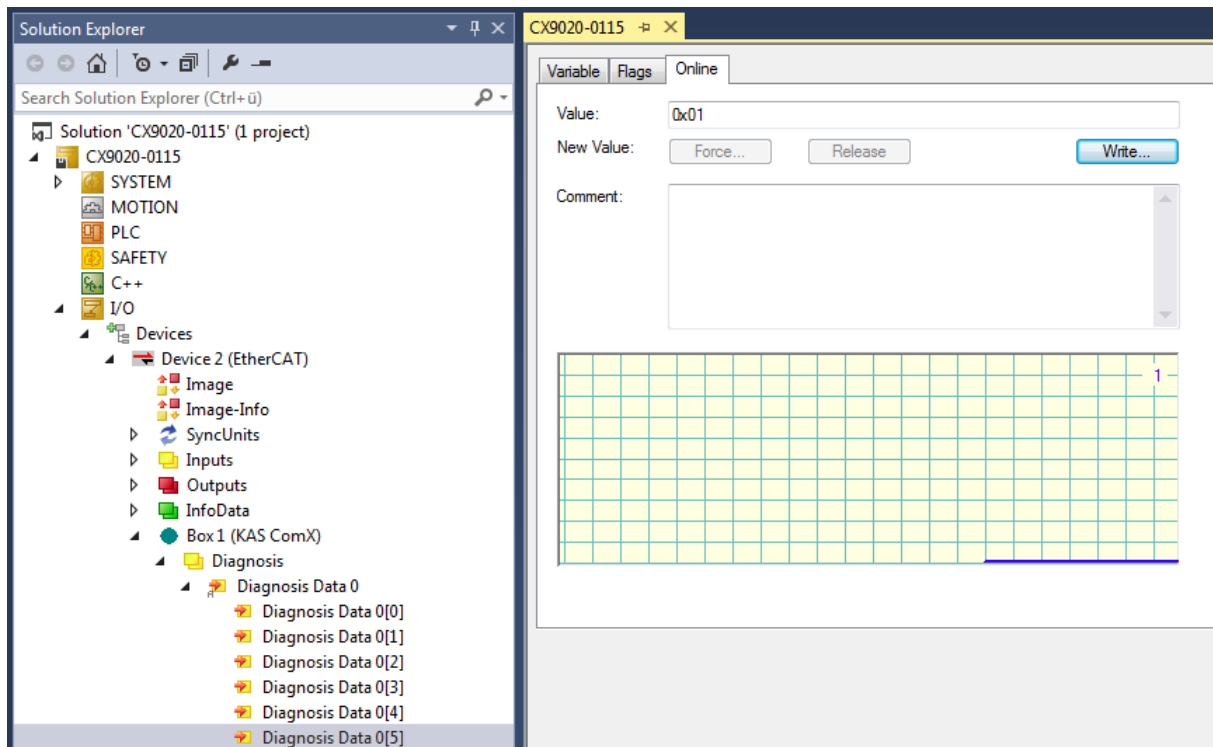
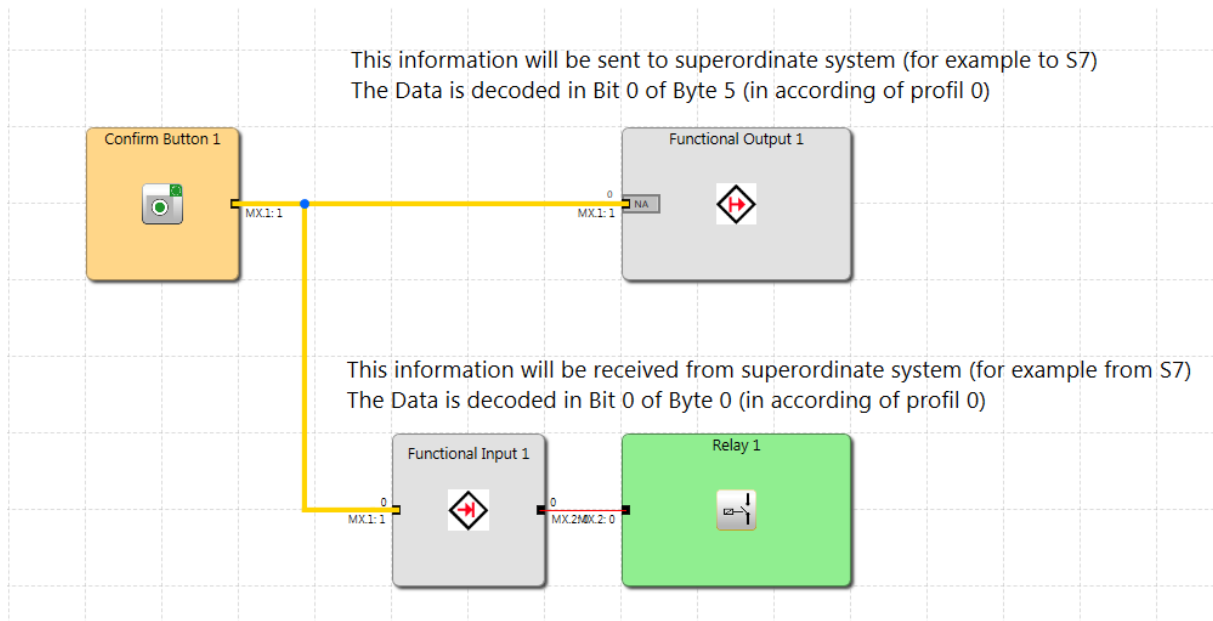

In addition, up to 32 non-safe functional inputs are available on the PSC1, via which digital information can be received from the higher-level standard controller. In the "SafePLC2" function diagram, these inputs must always be AND-linked to a safe input and can then be reused as required.

In the following example, the functional output (Byte0, Bit 0) is written in the higher-level standard control and AND-linked to a safe input in PSC1 (Confirm Button 1). Both have a high signal, relay 1 is activated.

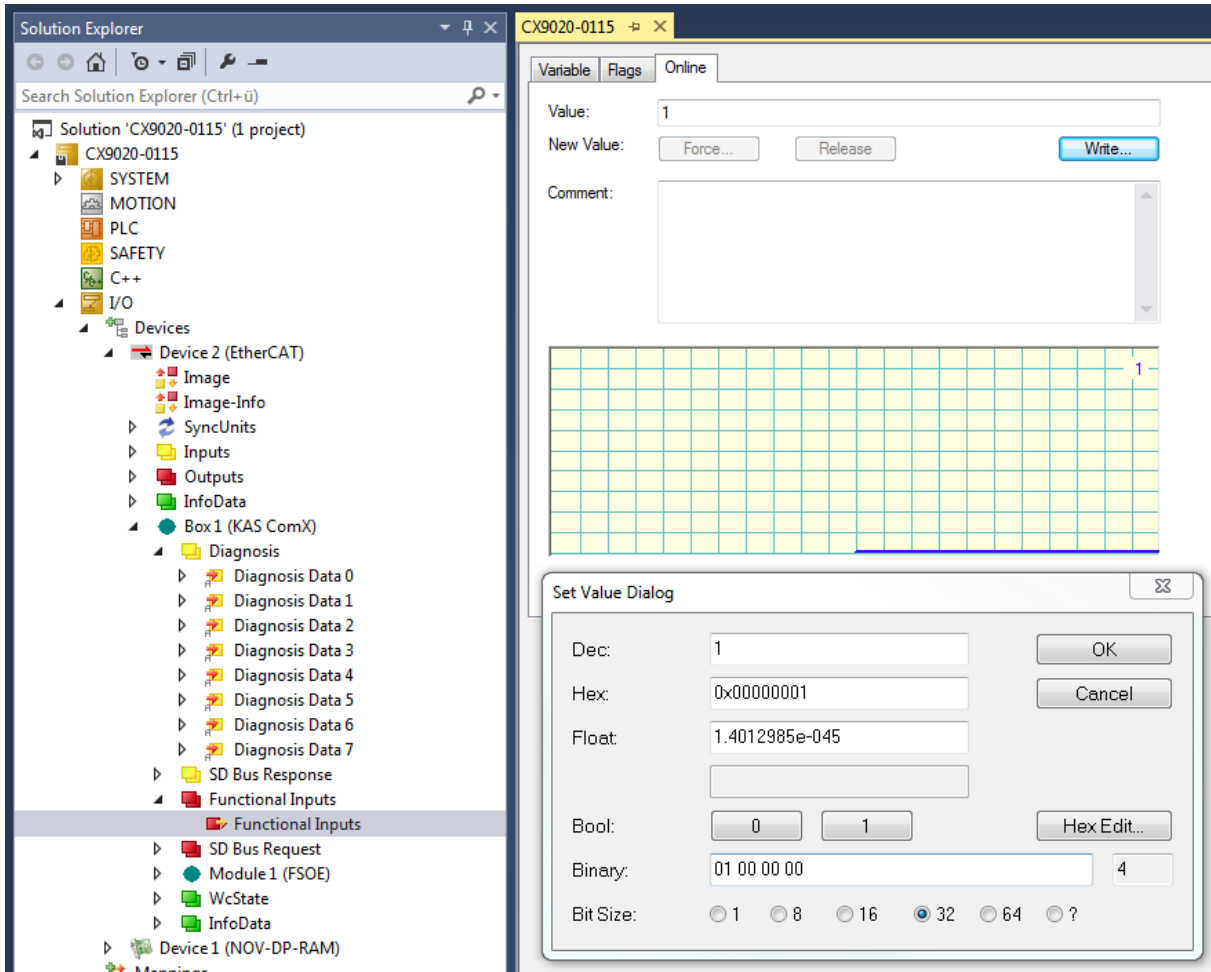

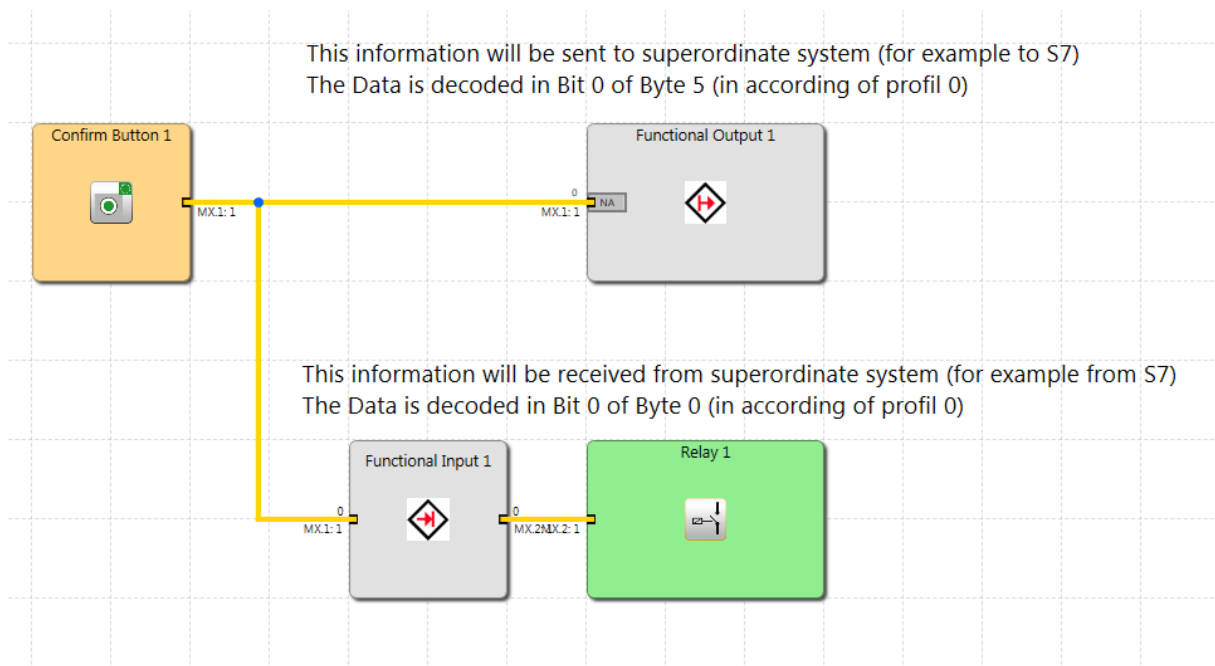

In the following example, the functional output (Byte0, Bit 0) is written in the higher-level standard control and AND-linked to a safe input in PSC1 (Confirm Button 1). "Confirm Button 1" has a low signal, the functional output from the standard control has a high signal, Relay 1 is not activated.

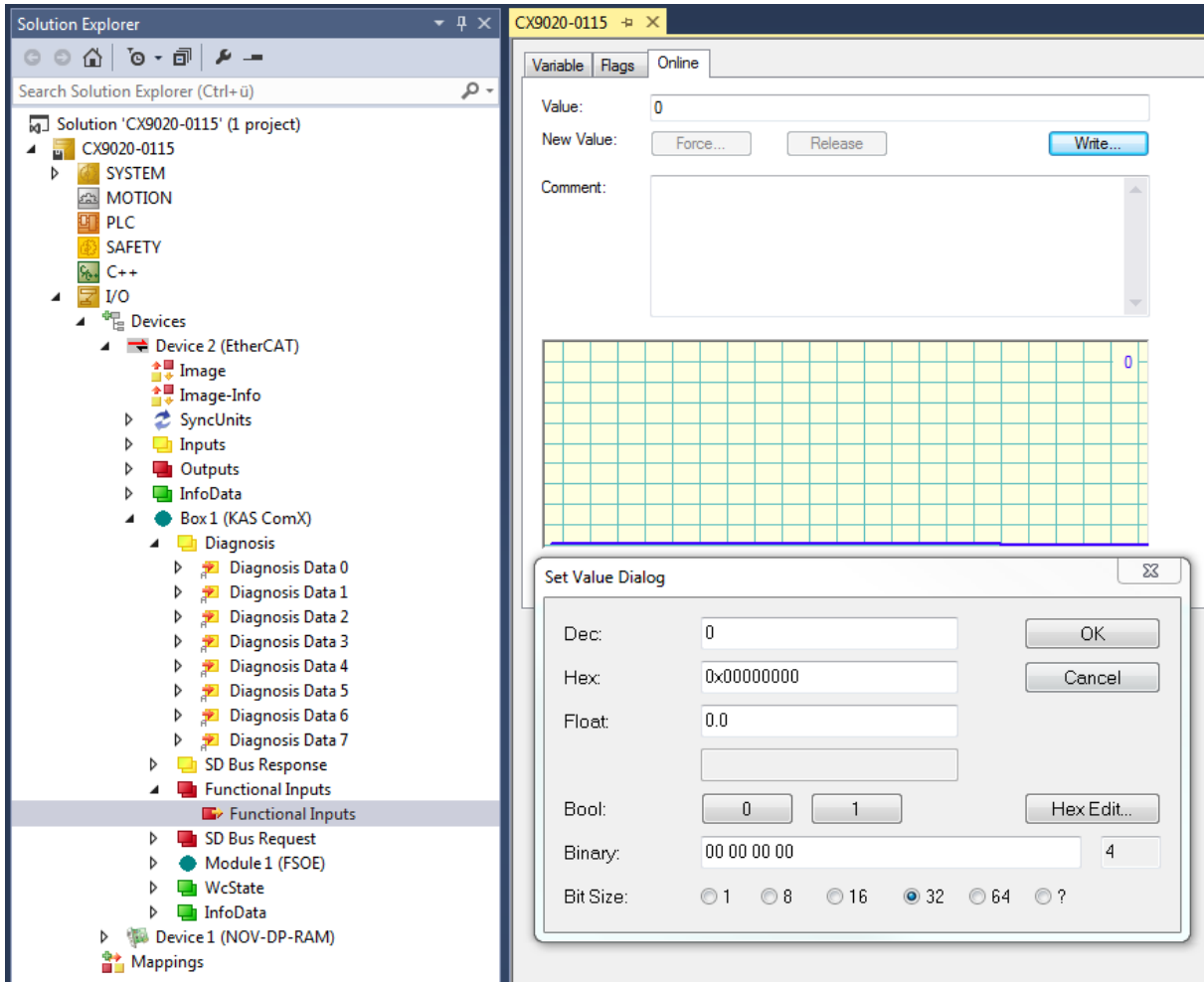

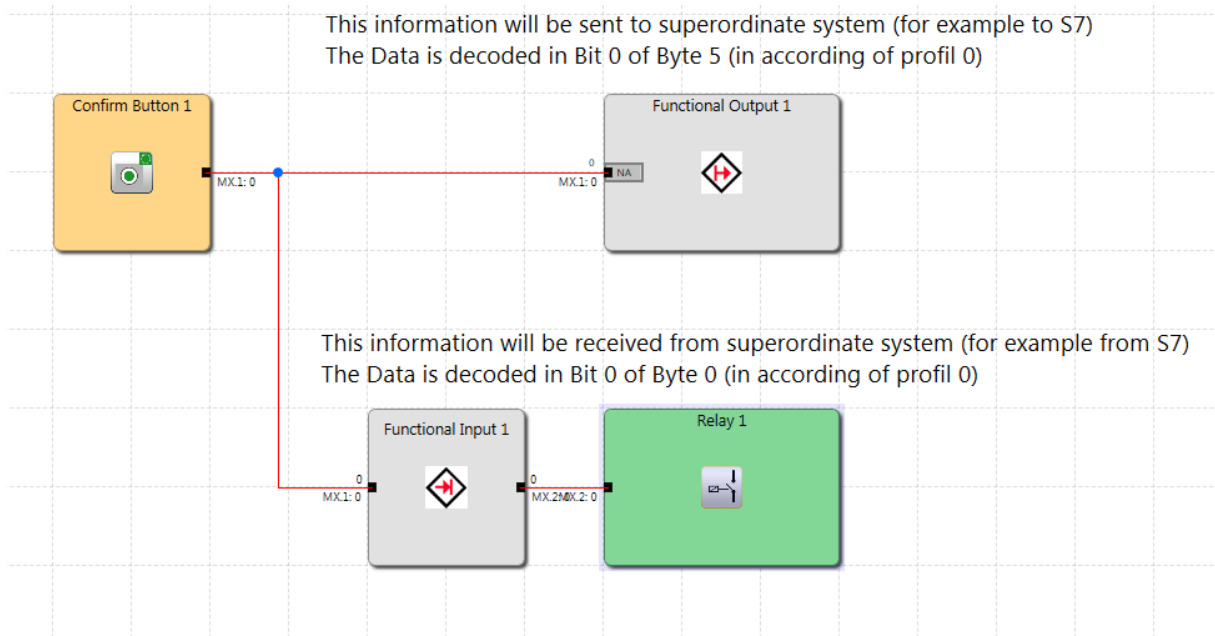

13.1.5 Create safety project

Right-click "SAFETY" in the tree view on the left and "Add New" item in the context menu.

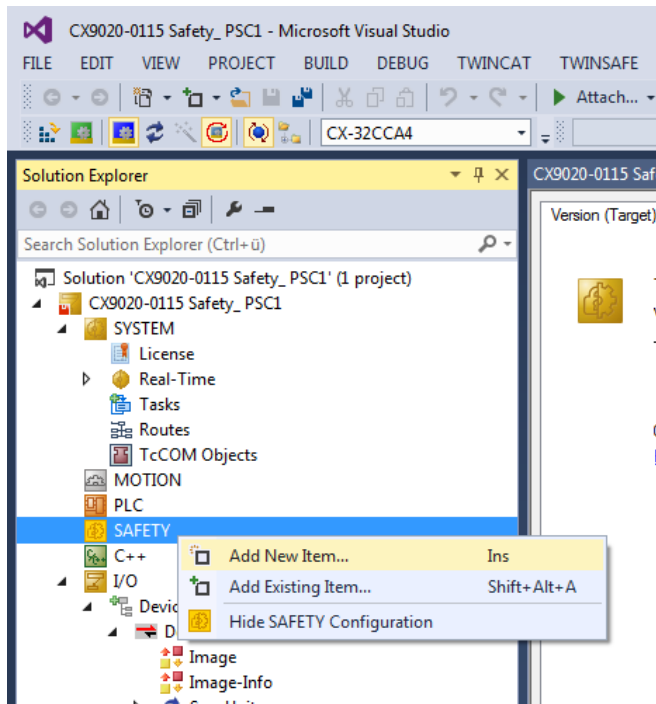

Select "TwinCAT Default Safety Project" and specify the project name. Confirm your entries with "Add".

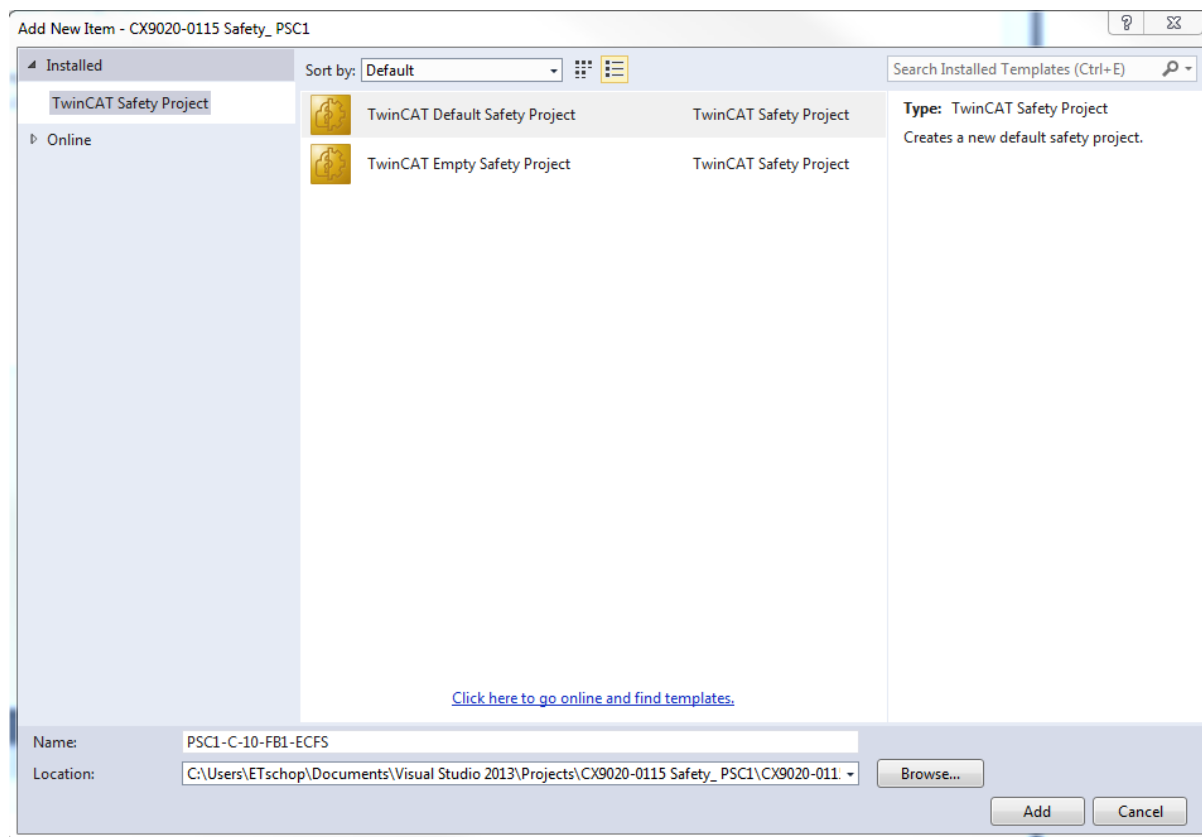

If necessary, please select the "Target System" and the "Programming Language". Confirm your selection with "Ok".

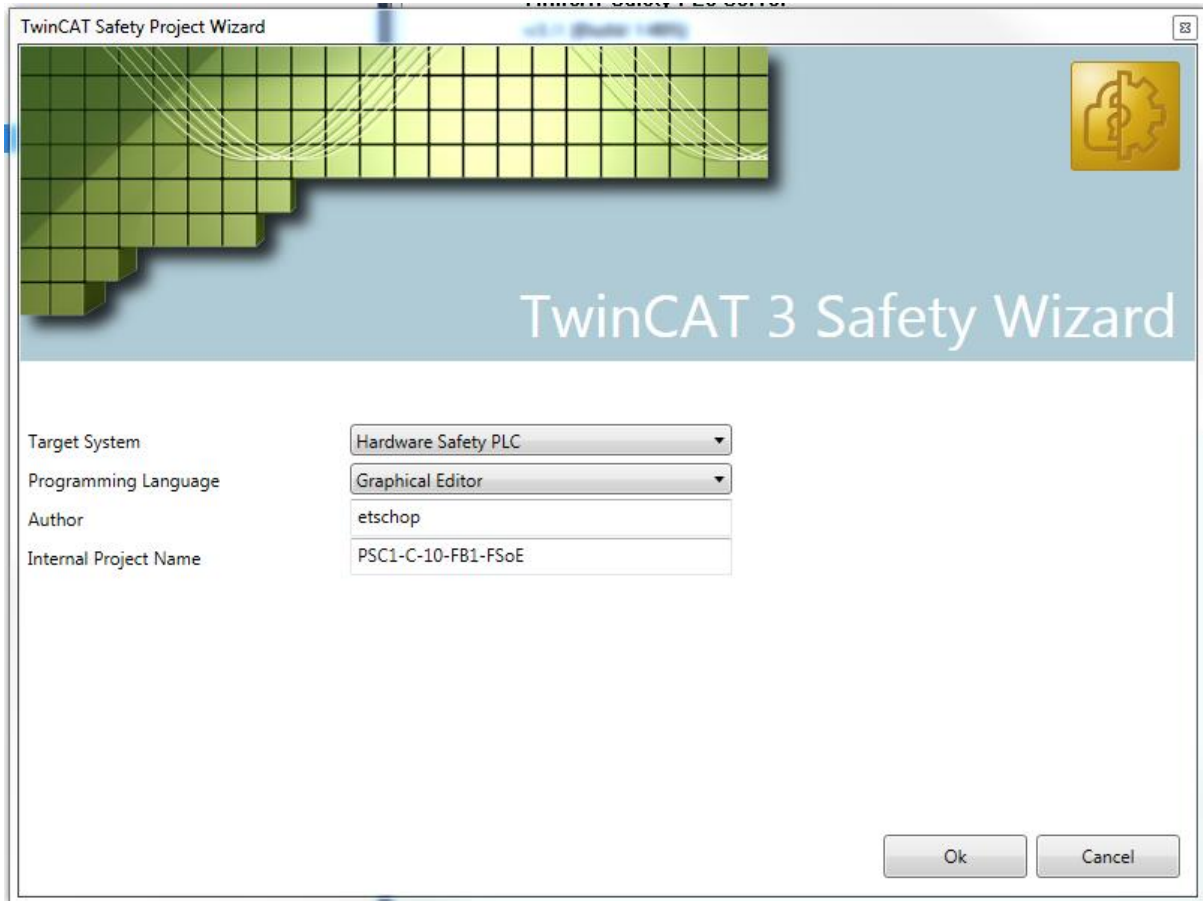

Communication between the Safety Logic and the I/O level is implemented via an alias level. In this alias level (sub-node \ alias devices), corresponding "Alias Devices" are created for all safe inputs and outputs, but also for standard signals. This can also be done automatically for the safe inputs and outputs using the

I/O configuration.

Right-click on "Alias Devices" in the tree view on the left and select "Import Alias Device(s)" in the context menu.

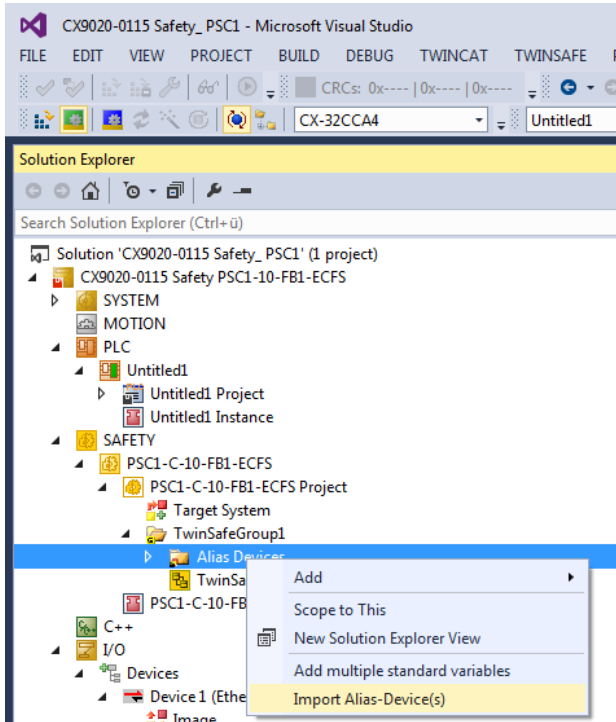

If the automatic import from the I/O configuration is started, a selection dialogue is opened via which the individual terminals that are to be imported automatically can be selected.

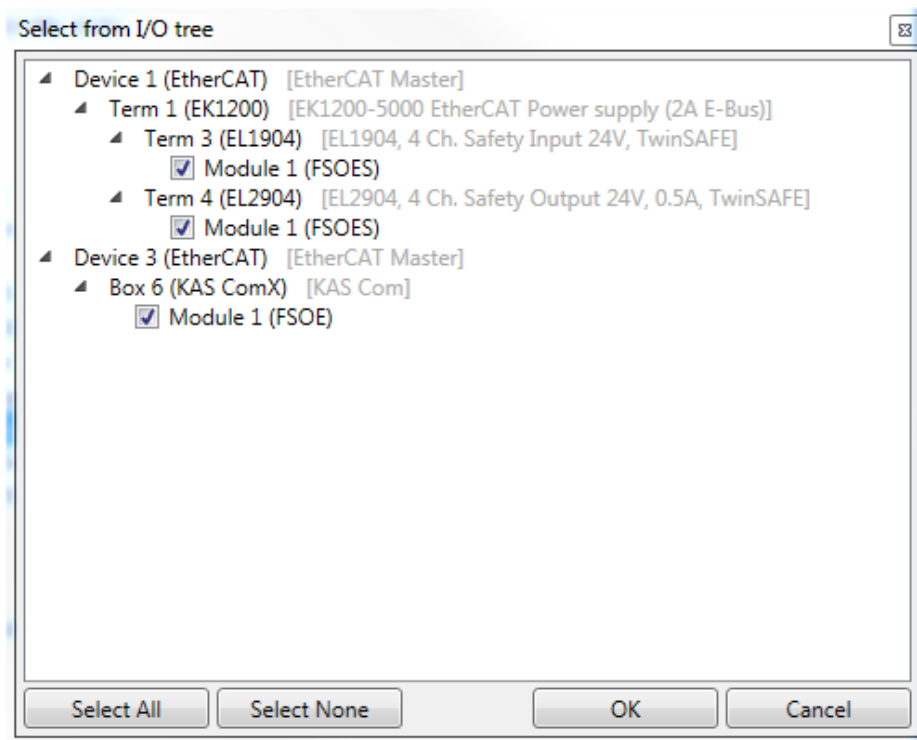

After closing the dialogue, the Alias Devices are created in the safety project.

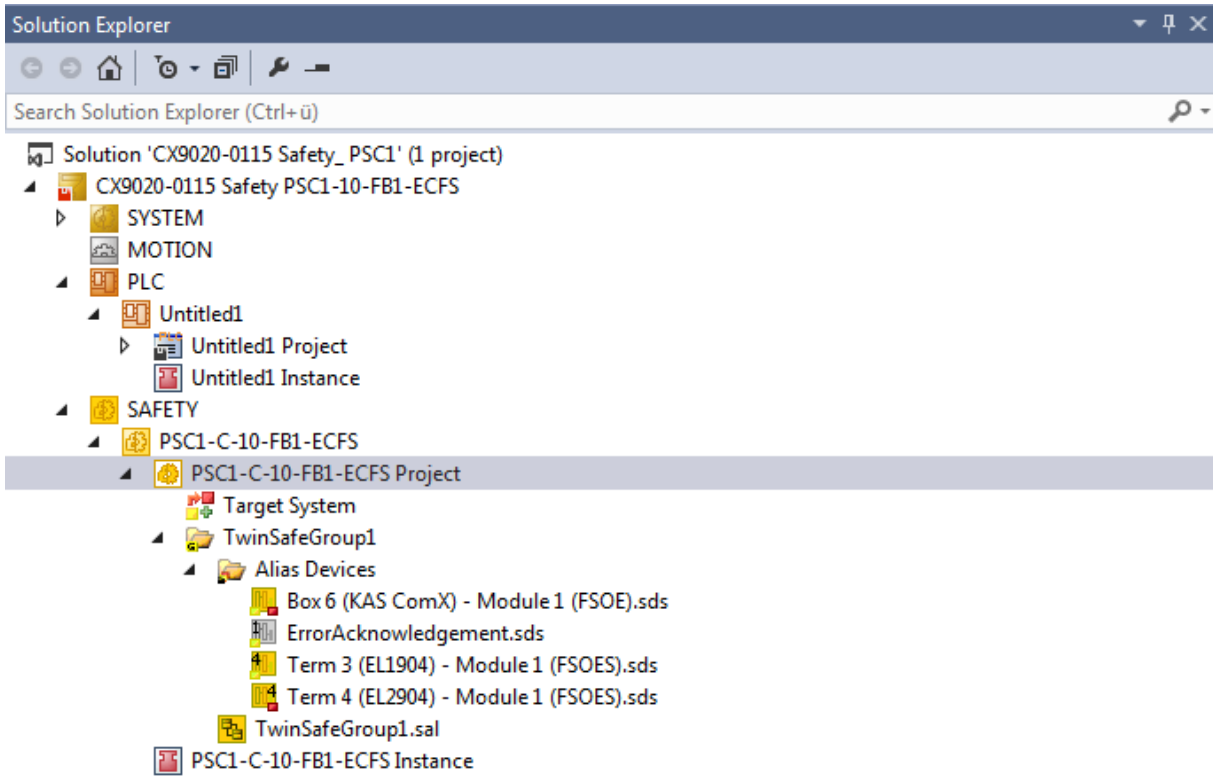

The Target System is permanently set to TwinCAT Safety PLC in the drop-down list and is linked to the task with which the TwinCAT Safety PLC is to be executed via the "Link" button next to "Append to Task". Left-click on "Target System" in the tree view and then click on "Physical Device" in the context menu.

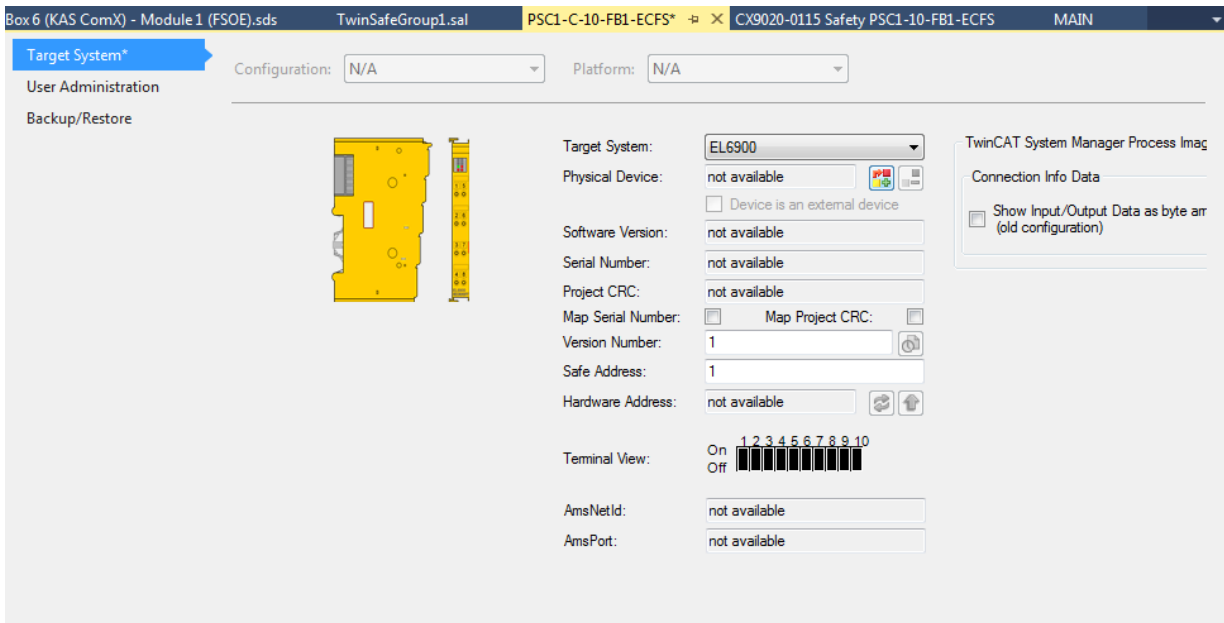

Select the master device in the context menu and confirm your entry with "OK".

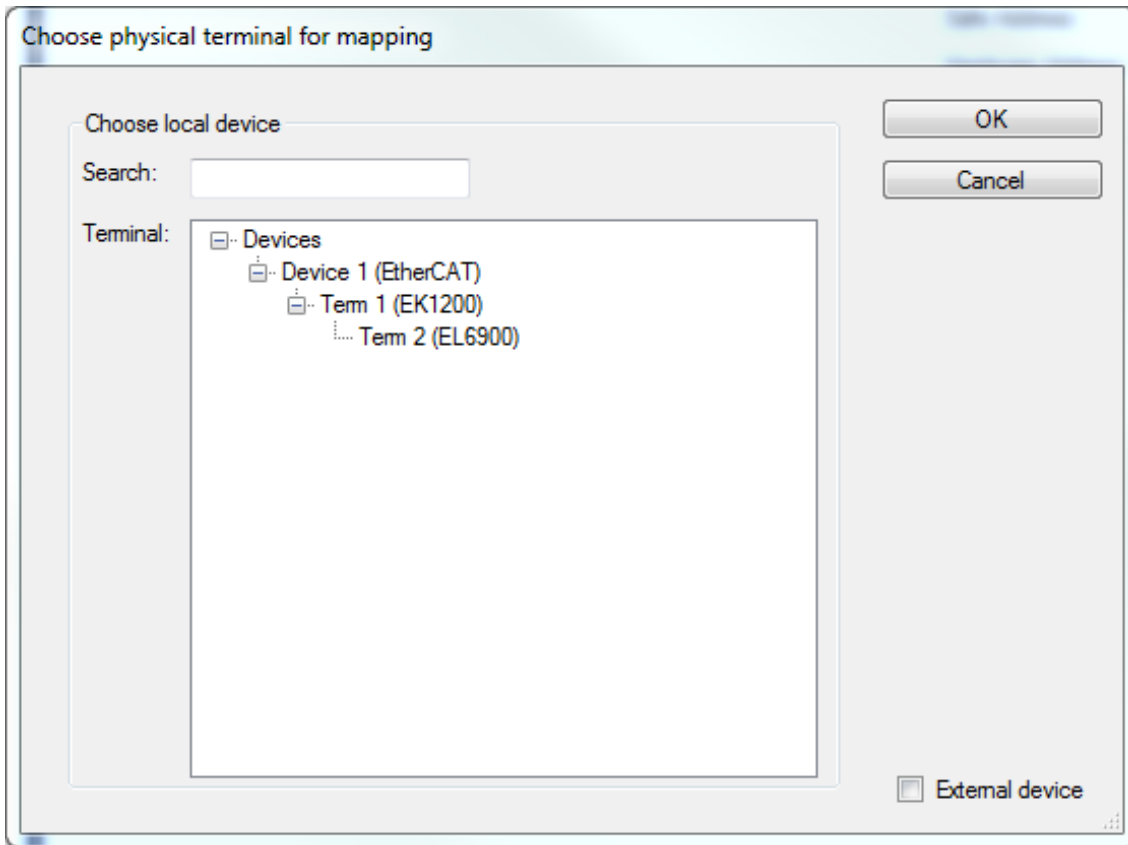

After closing the dialogue, the Master Device is linked to the task.

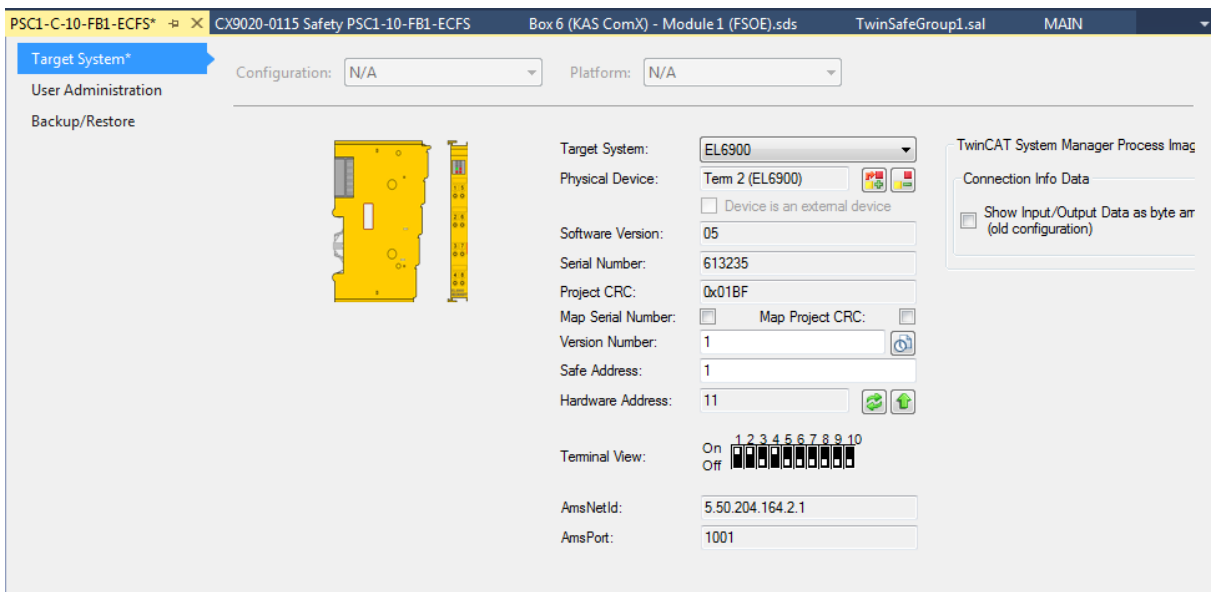

The hardware address of the target system may have to be checked and set if necessary. If the address is known to you, enter it in the "Safe Address" tab. If the address is unknown, it can be read out. Activate the Config Mode: "TWINCAT => Restart TwinCAT (Config Mode)".

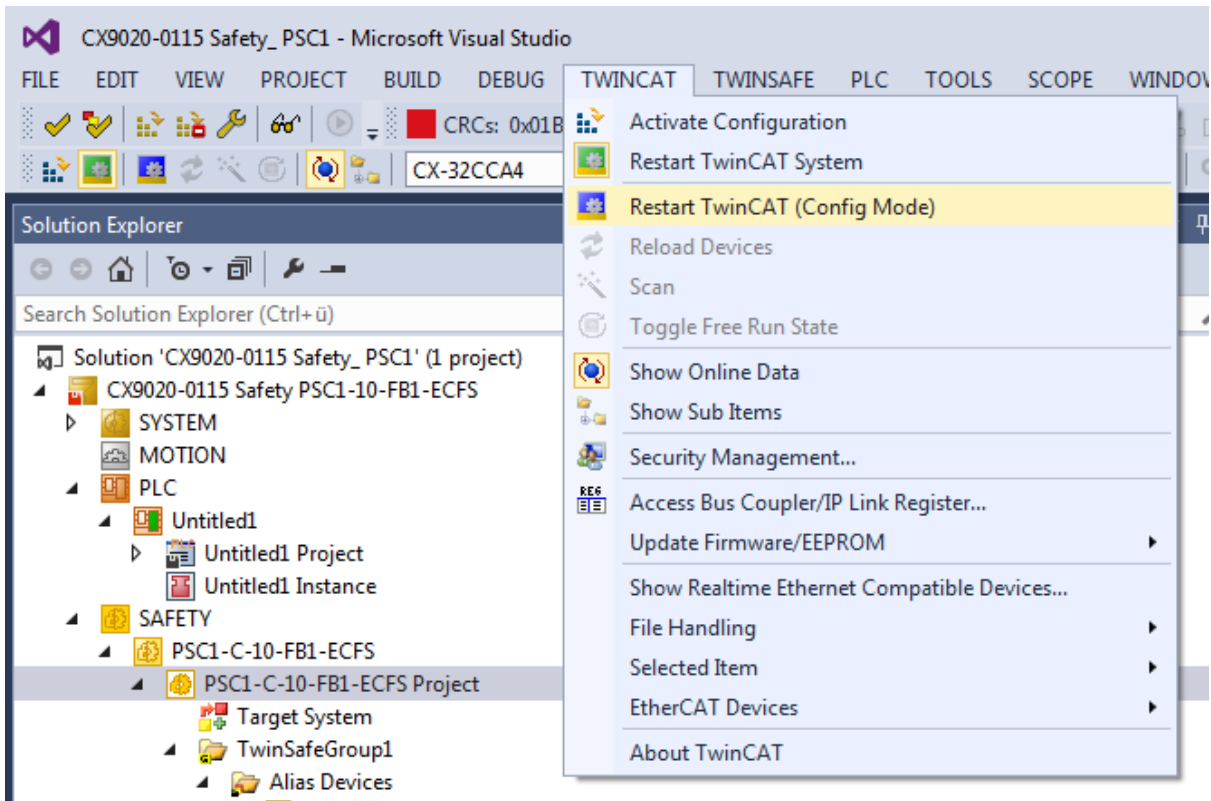

Confirm your selection with "OK".

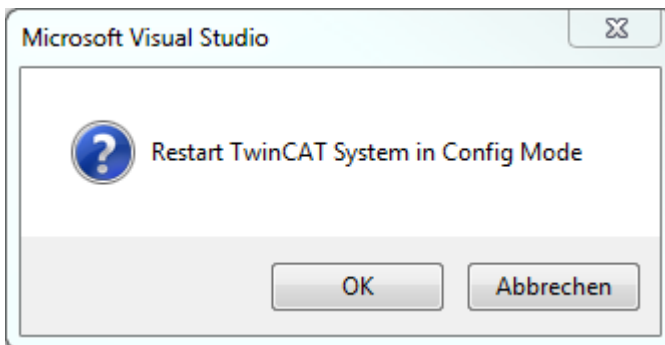

Confirm the readout of the I/O peripherals with "Yes".

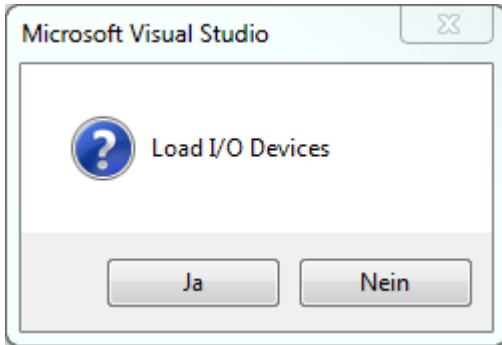

Confirm activation of the "Free Run" mode.

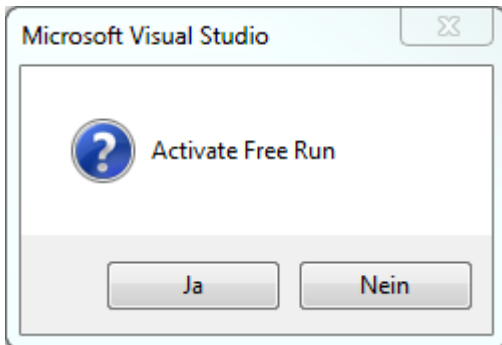

Read out the hardware address by clicking on the icon shown below.

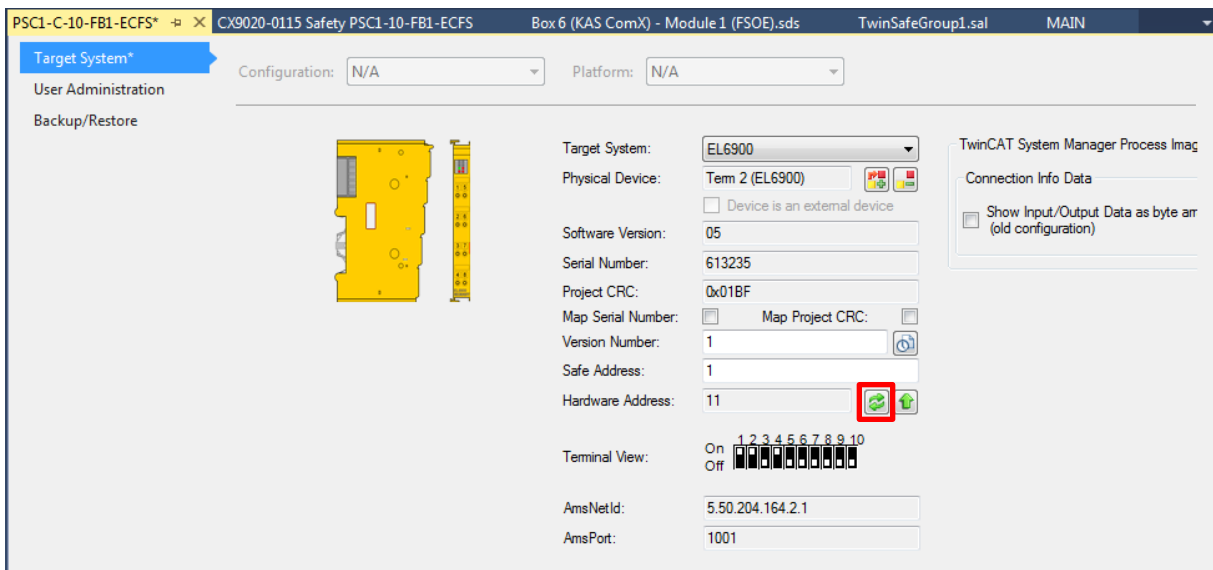

Enter the hardware address read out into the "Safe Address" tab.

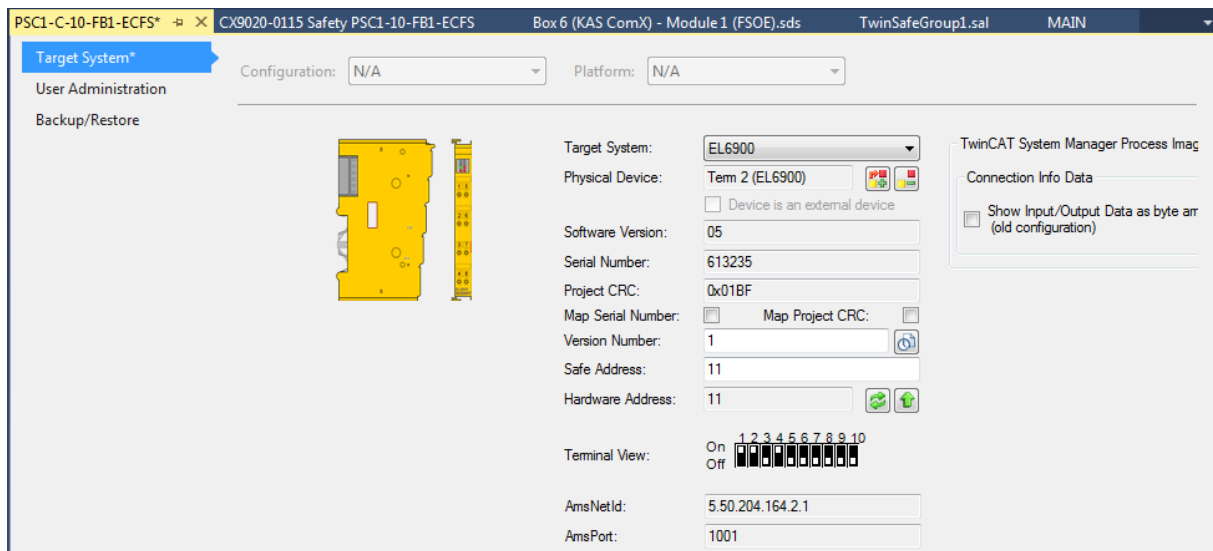

The safe FSoE address of the PSC control must correspond to the address preset in SafePLC2 (in the example the address 123). The automatic readout of the DIP switch addressing switch is not supported for PSC1 and is signalled by the system by the message shown below.

```

❌ 1 19.12.2017 13:39:00 962 ms | 'Box 6 (KAS ComX)' (1001): CoE ('InitUp' 0xf980:01) - SDO
Abort ('Object does not exist in the object dictionary.', 0x06020000).
    
```

Left-click on "Box xx (KAS ComX) - Module x" in the tree view and set the FSoE address manually in the context menu.

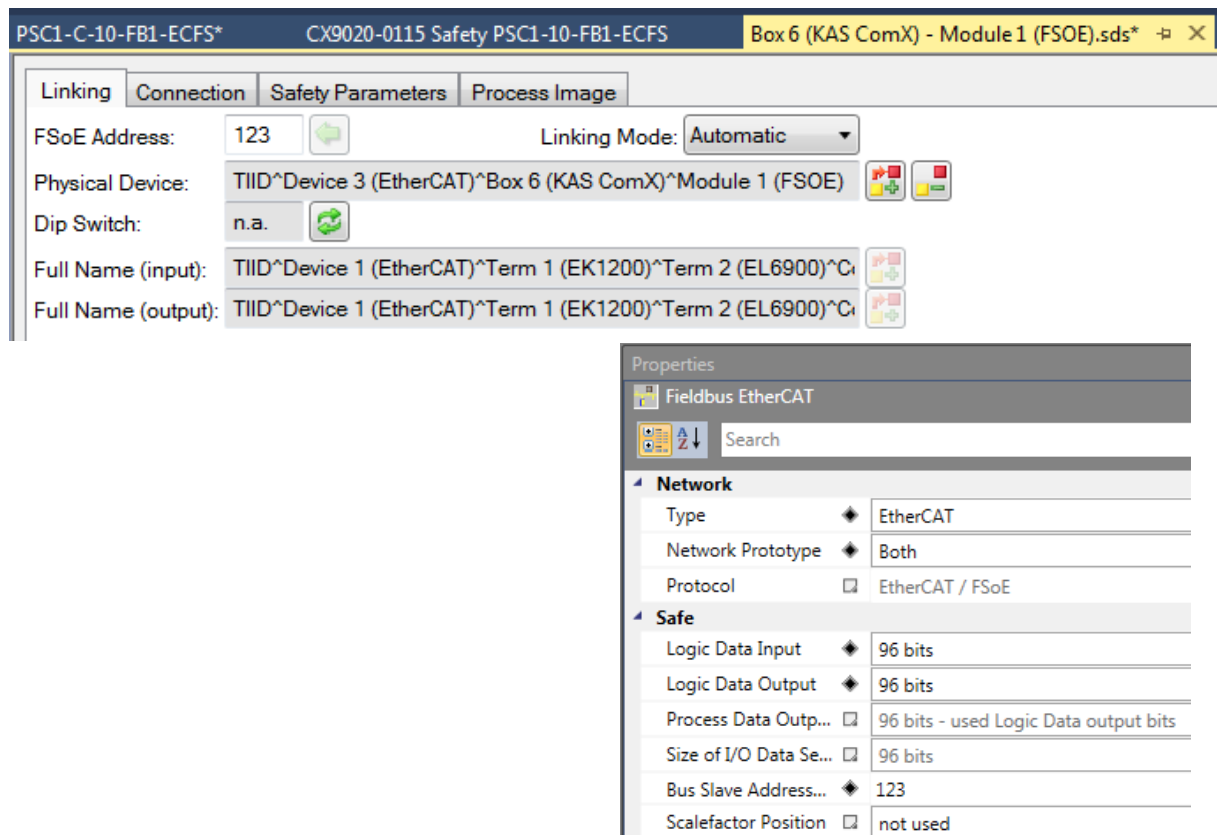

The screenshot shows the configuration window for a Fieldbus EtherCAT device. The main window has tabs for Linking, Connection, Safety Parameters, and Process Image. The 'Linking' tab is active, showing the following configuration:

- FSoE Address: 123
- Linking Mode: Automatic
- Physical Device: TIID^Device 3 (EtherCAT)^Box 6 (KAS ComX)^Module 1 (FSOE)
- Dip Switch: n.a.
- Full Name (input): TIID^Device 1 (EtherCAT)^Term 1 (EK1200)^Term 2 (EL6900)^Ci
- Full Name (output): TIID^Device 1 (EtherCAT)^Term 1 (EK1200)^Term 2 (EL6900)^Ci

The 'Properties' window is open, showing the following settings:

- Fieldbus EtherCAT
- Search: []
- Network**
 - Type: EtherCAT
 - Network Prototype: Both
 - Protocol: EtherCAT / FSoE
- Safe**
 - Logic Data Input: 96 bits
 - Logic Data Output: 96 bits
 - Process Data Outp...: 96 bits - used Logic Data output bits
 - Size of I/O Data Se...: 96 bits
 - Bus Slave Address...: 123
 - Scalefactor Position: not used

Left-click on "TwinSafeGroupX.sal" in the tree view to create a safety-related program. Insert logical links and assign the required variable names.

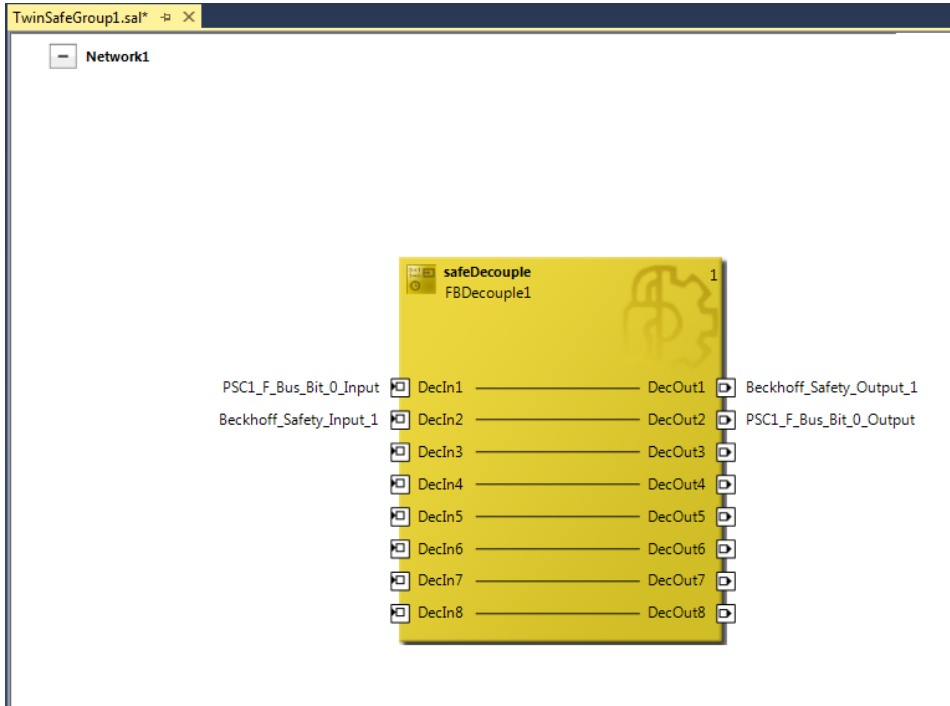

The variables created are displayed in the lower navigation window under "Variables => Variable Mapping".

Variable Mapping

Assigned Variable	Direction	Alias Port	Port Name	Instance Name	Function Name
PSC1_F_Bus_Bit_0_Input	input	...	DecIn1	FBDecouple1	safeDecouple
Beckhoff_Safety_Output_1	output	...	DecOut1	FBDecouple1	safeDecouple
Beckhoff_Safety_Input_1	input	...	DecIn2	FBDecouple1	safeDecouple
PSC1_F_Bus_Bit_0_Output	output	...	DecOut2	FBDecouple1	safeDecouple

Safety Project Online View | Variable Mapping | Error List | Output

Click on "Alias Port" in the "Variable Mapping" window to link the desired variable with previously imported I/Os.

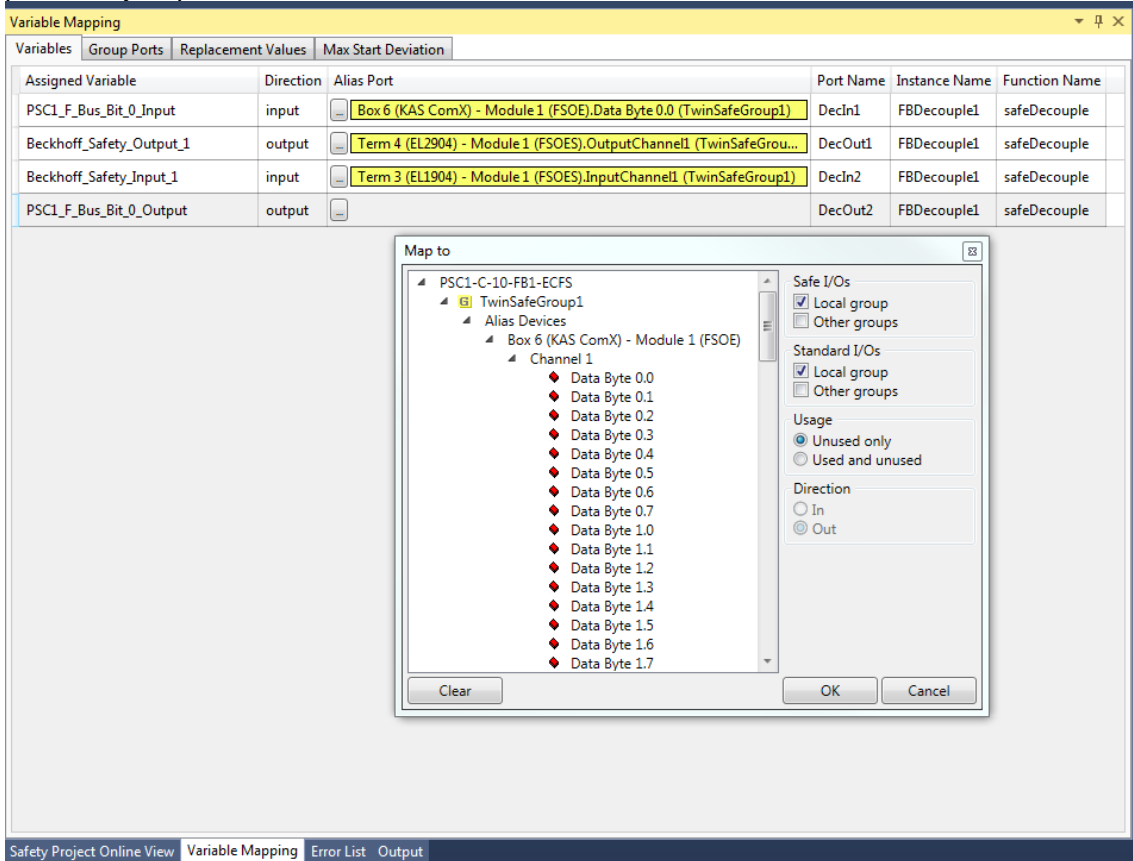

In the group configuration, mapping must still be performed for Error Acknowledge (e.g. for reintegration after a communication interruption). This signal is linked via the "ERR Ack" link in the navigation window under "Variable Mapping => Group Ports".

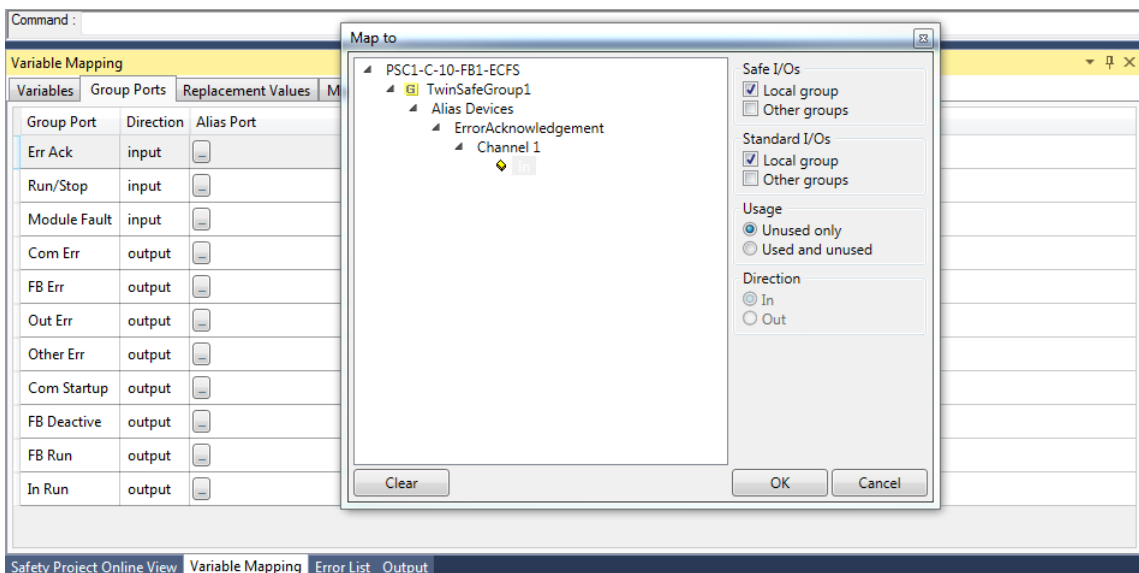

For simplicity, this signal is linked to a global variable in the following example. Right-click on "PLC" in the tree view on the left and click on "Add New Item" in the context menu.

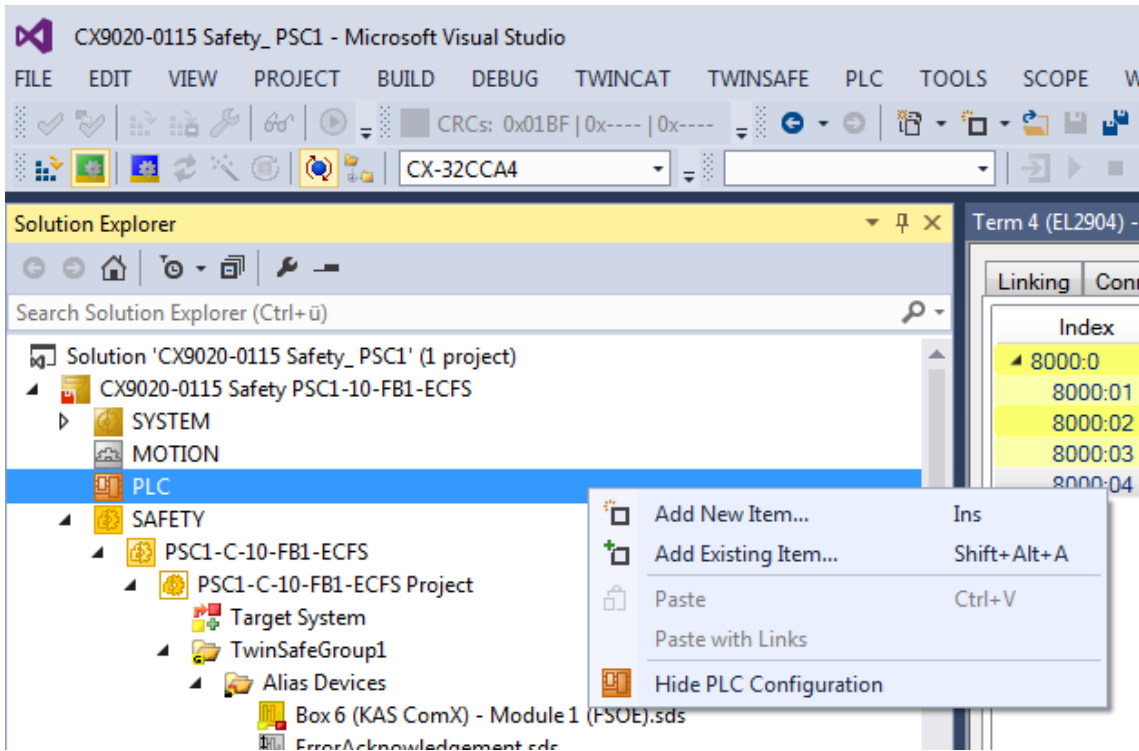

Select "Standard PLC Project" in the following dialogue and confirm your selection with "Add".

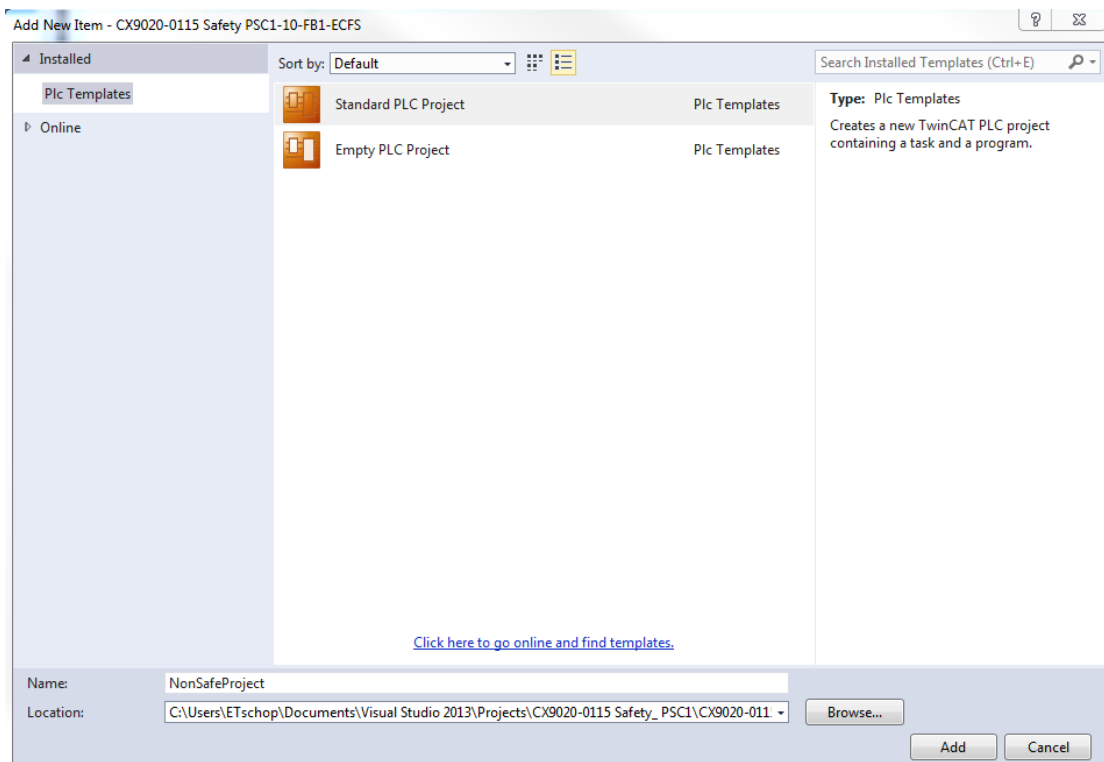

Right-click on "GVLs" in the tree view on the left, then click on "Add" in the context menu and then on "Global Variable List...".

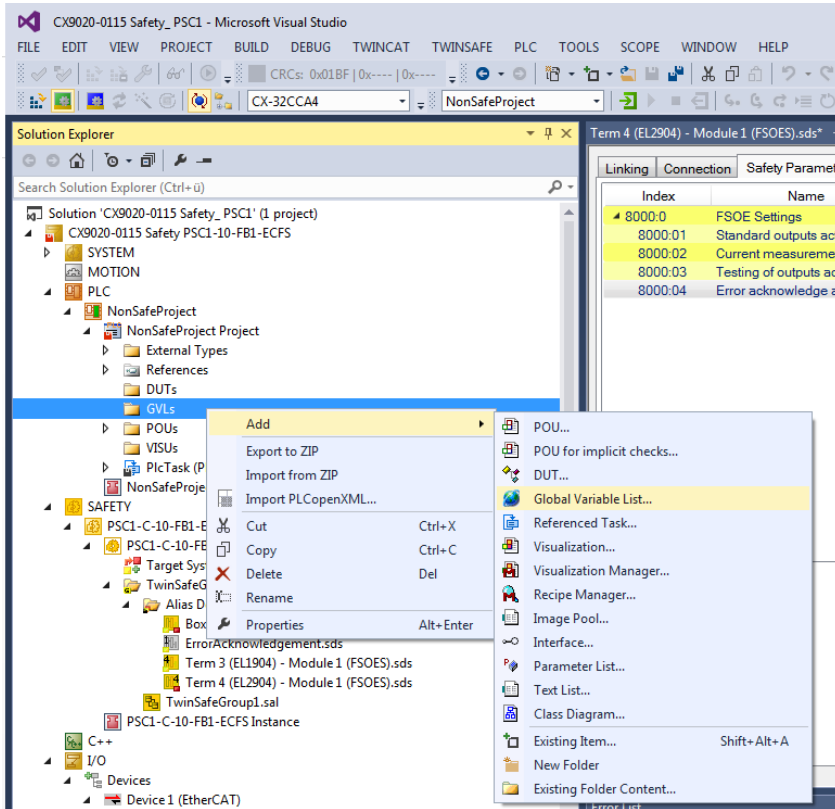

Select "Open" in the following dialogue.

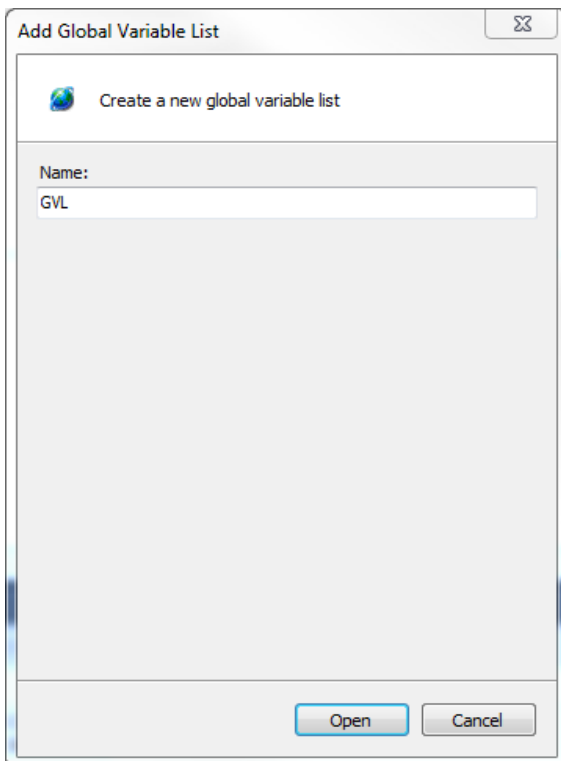

Enter the following instruction in the GVL: "bReset AT %Q*: BOOL;"

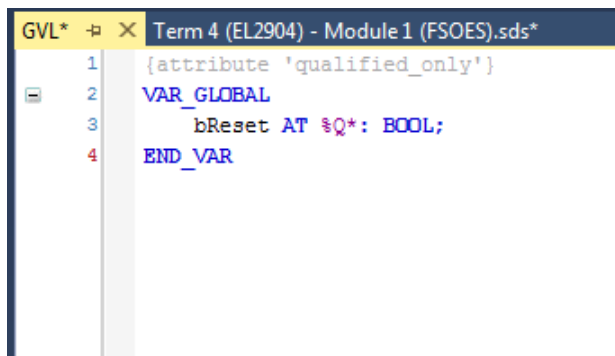

```
GVL* [X] Term 4 (EL2904) - Module 1 (FSOES).sds*
1 {attribute 'qualified_only'}
2 VAR_GLOBAL
3   bReset AT %Q*: BOOL;
4 END_VAR
```

Compile your project: "Build => Build Solution".

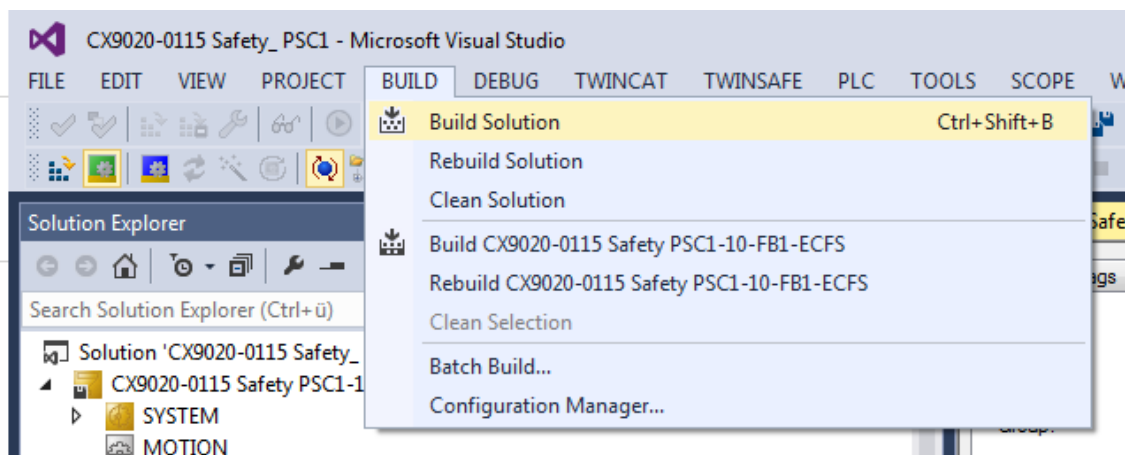

Click on "NonSafeProject Instance => PlcTask Outputs" on the left side of the tree view

=> GVL.bReset".

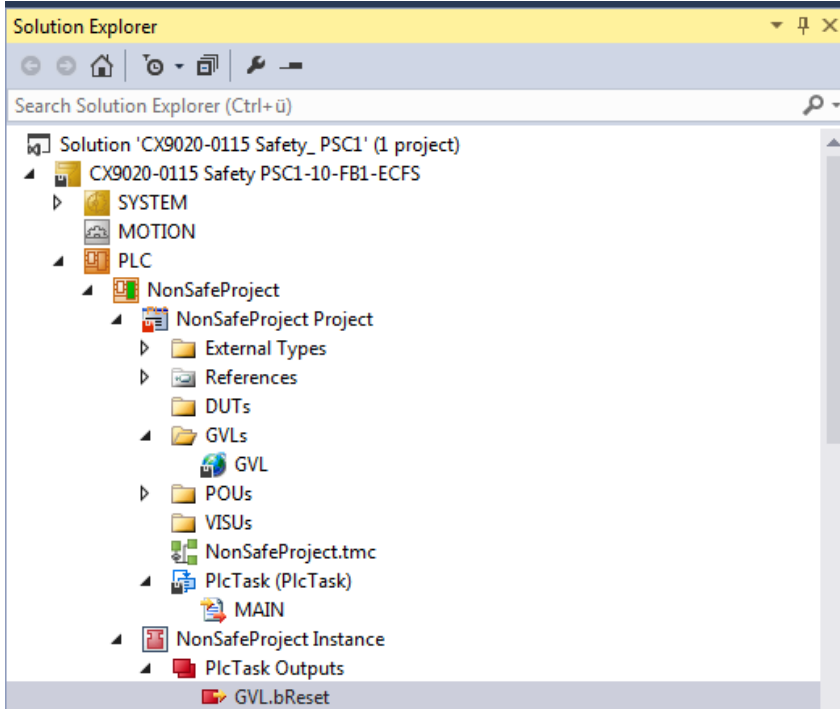

Select "Linked to" in the following dialogue.

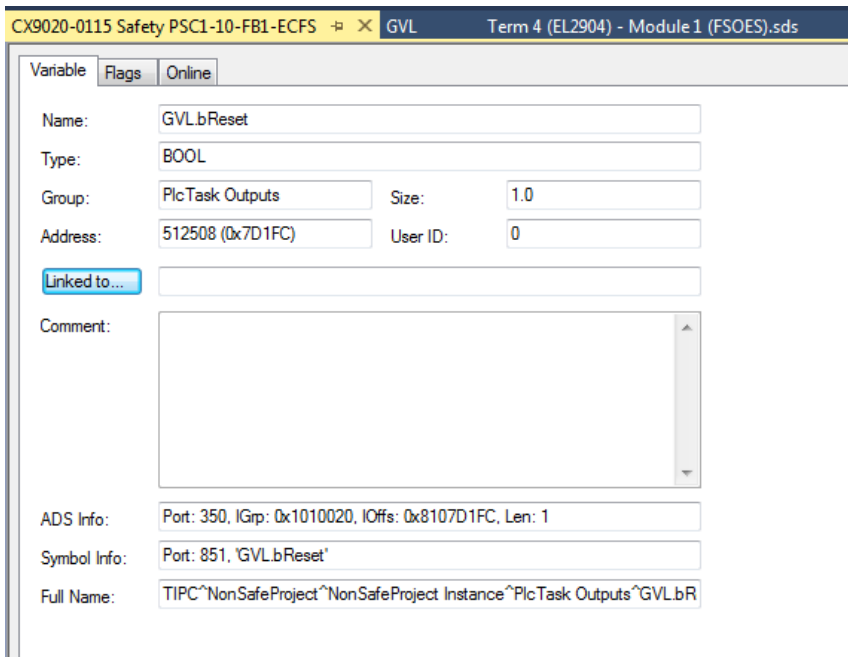

Add a shortcut to the "ERR Ack" signal link.

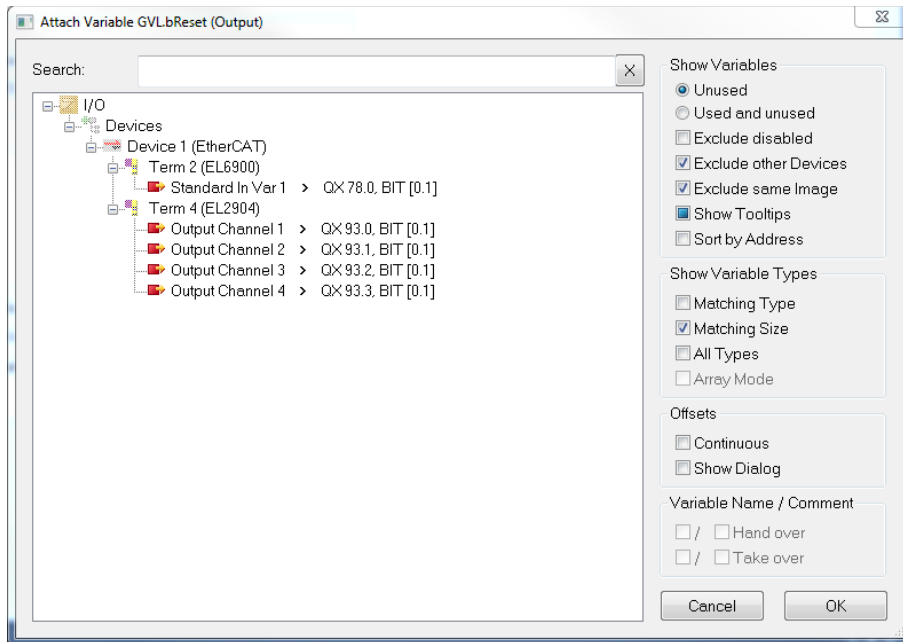

Now the safety-related program can be compiled. Click on "PSC1-C-10-FB1-ECFS Project (your project name)" in the tree view on the left and on the "Verify Safety Project" icon in the upper navigation bar.

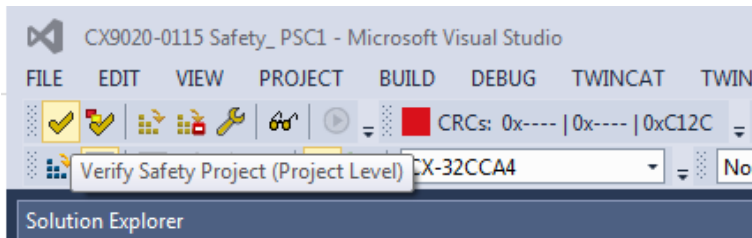

If your safety-related project has been compiled without errors, the project can be transferred to the EtherCAT-FSoE-capable master controller. To do this, click on "Download Safety Project" in the upper navigation bar.

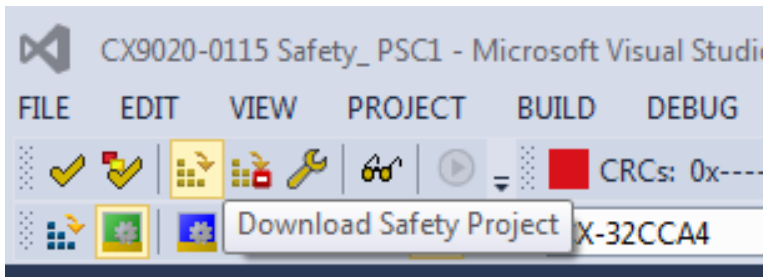

Please enter the stored user name, the serial number of the target system and the password and then click "Next".

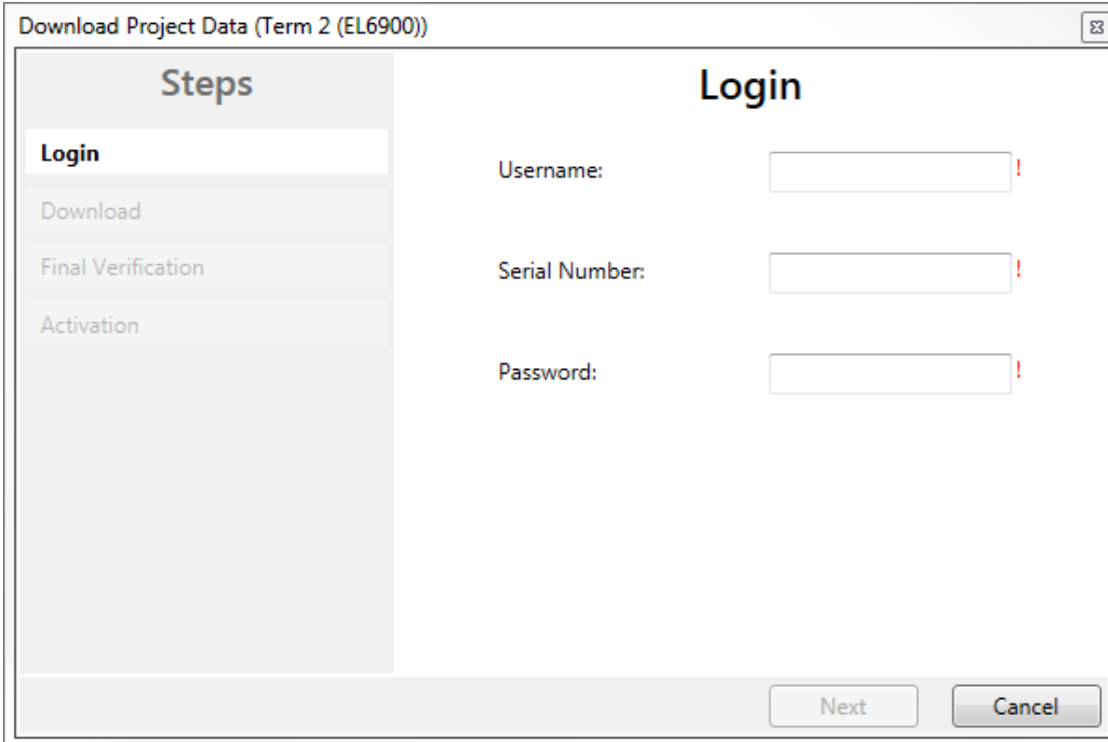
A screenshot of a dialog box titled 'Download Project Data (Term 2 (EL6900))'. On the left, there is a 'Steps' list with 'Login' selected. On the right, under the 'Login' heading, there are three input fields: 'Username:', 'Serial Number:', and 'Password:'. Each field has a red exclamation mark icon to its right. At the bottom right, there are 'Next' and 'Cancel' buttons.

The serial number of the target system can be read out on the left in the tree view under "PSC1-C-10-FB1-ECFS (your project name) => Target System".

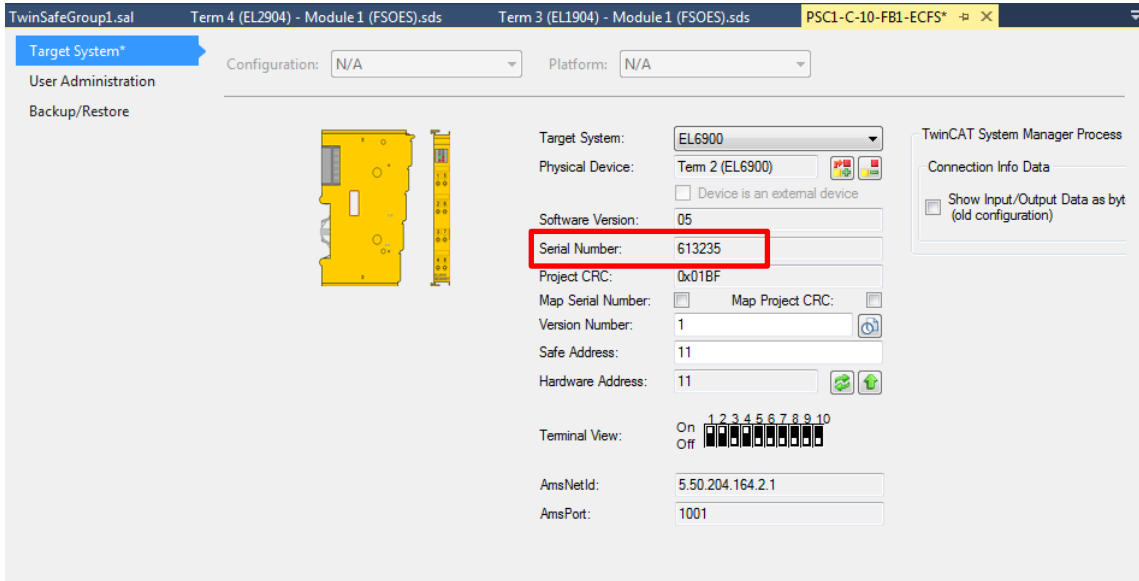

After the "Download" click on "Next".

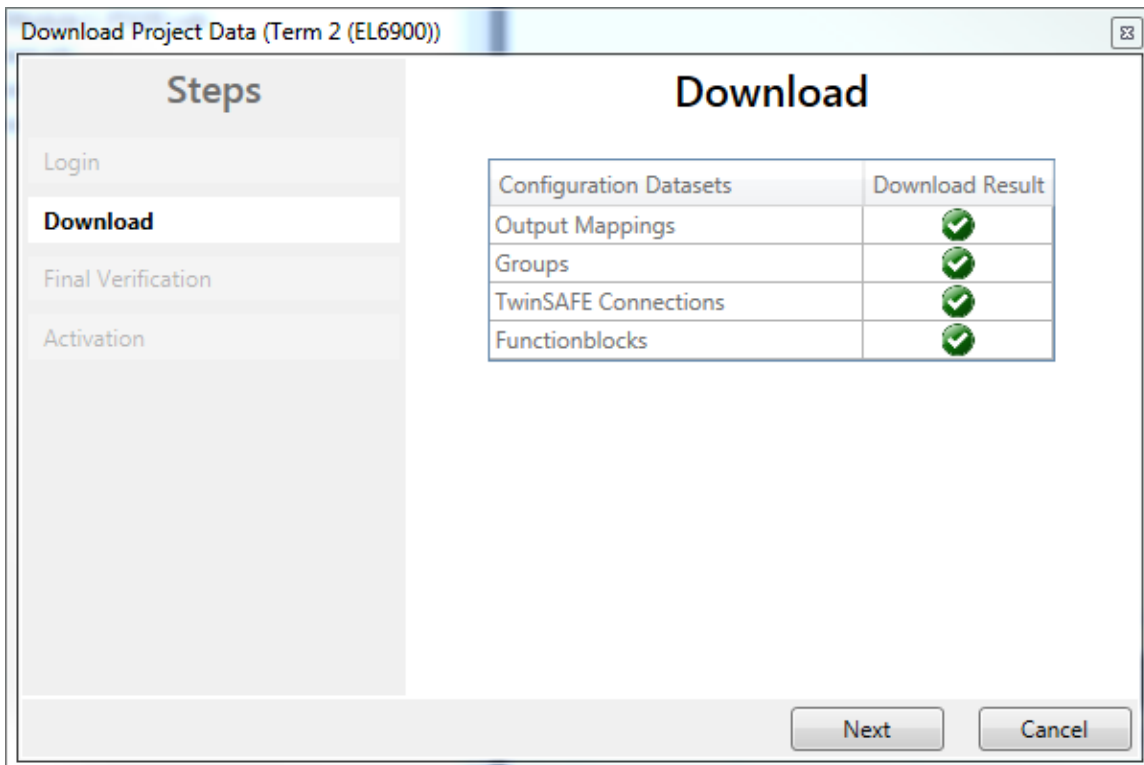

After "Final Verification" click on "Next".

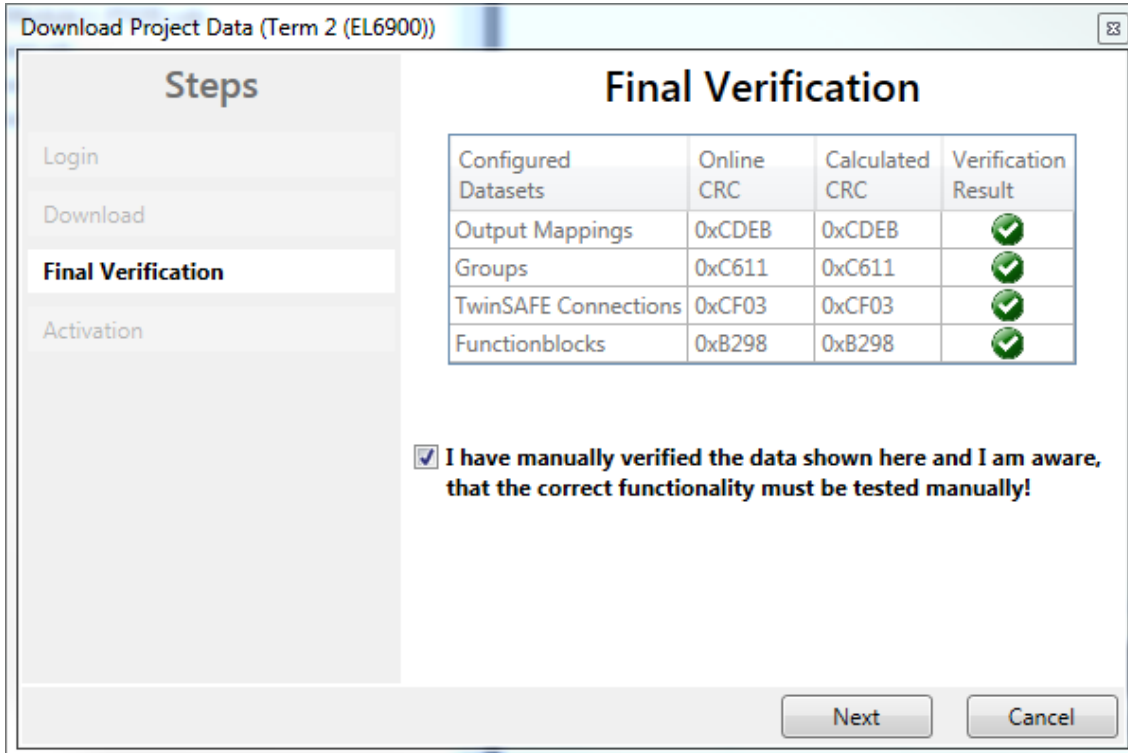

Click on "Finish" to end the "Activation".

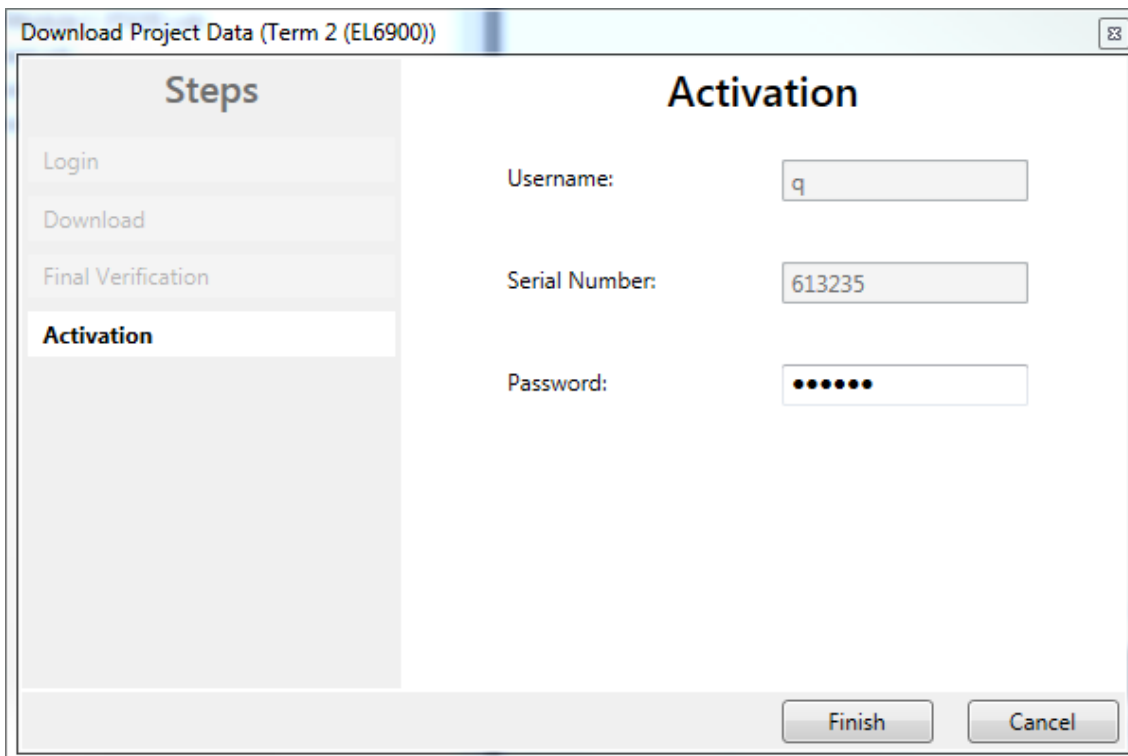

By confirming the CRC with the Finish button, the safety application is activated and executed. During the start-up of the safety application, the CRC is distributed to the safe communication devices configured within the CRC distribution. If the TwinCAT system is restarted, the safety application is now started without reactivation. After activation, the TwinSAFE CRC toolbar displays the identical online and offline CRC.

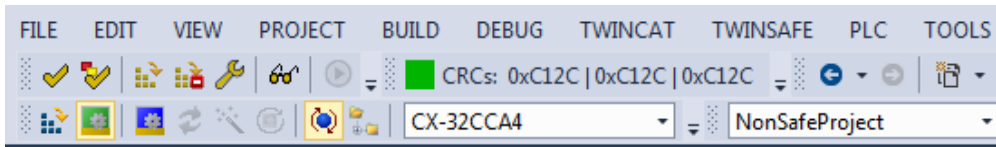

Now only the hardware must be acknowledged via the previously defined "bReset- Variable" (NonSafeProject Project[your project name] => PlcTask Outputs => GVL.bReset.

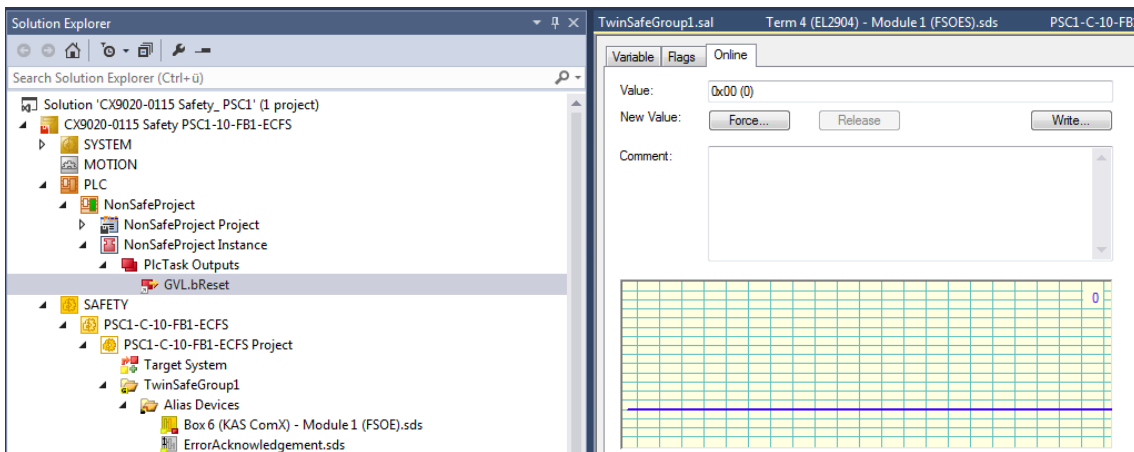

Click on Force and set the value in the following dialogue to "1" and then to "0".

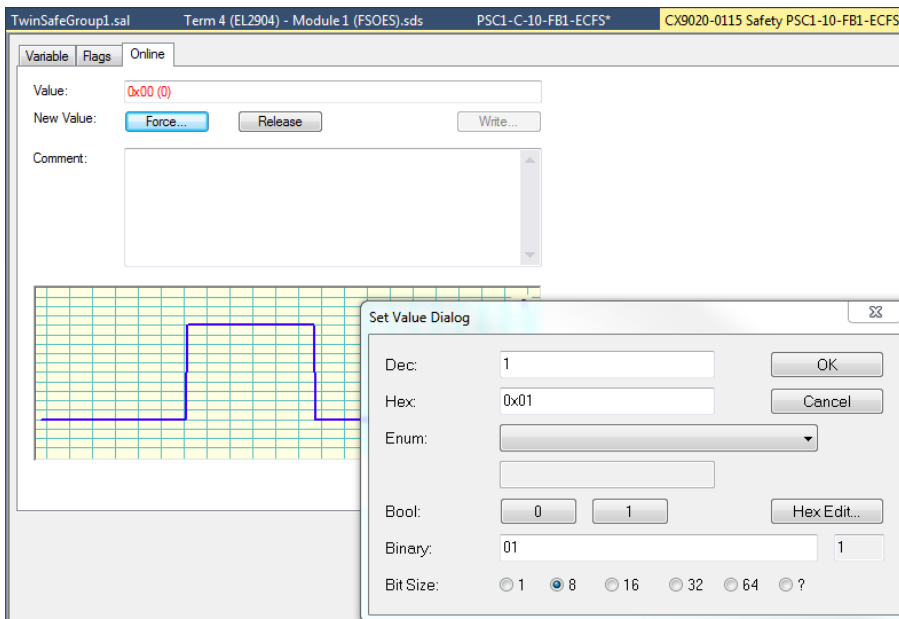

If you want to observe your variables, click on the "Show Online Data of Safety Project" icon in the upper navigation bar.



In the following example, the switching state of the button "Confirm Button 1" is written to SafePLC2 in bit 0 (F-Bus Output 1) and can be read in byte 0 (bit 0, PSC1_F_Bus_Bit_0_Input) of the configuration tool (TC3).

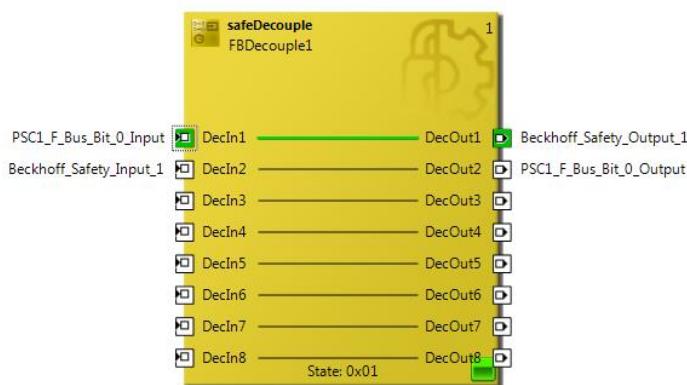
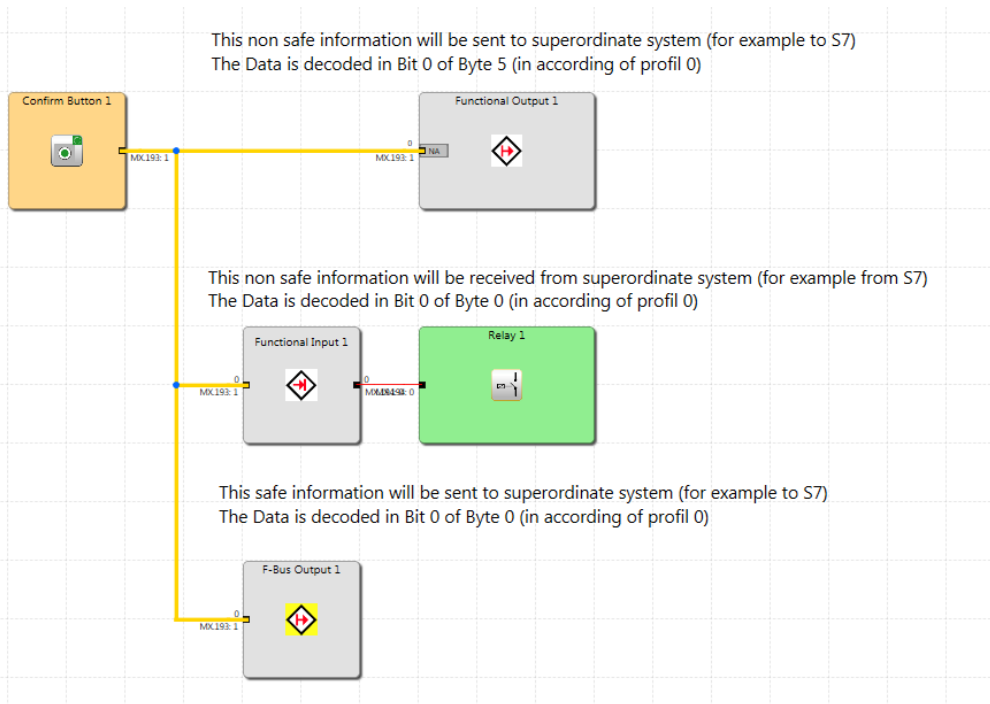

In addition, up to 96 safe functional inputs are available on the PSC1, via which digital information can be received by the higher-level safety controller.

In the following example, the functional output (PSC1_F_Bus_Bit_0_Output byte 0. bit 0) is written in the safety controller and read in the PSC1 in bit 0 (F bus input 1).

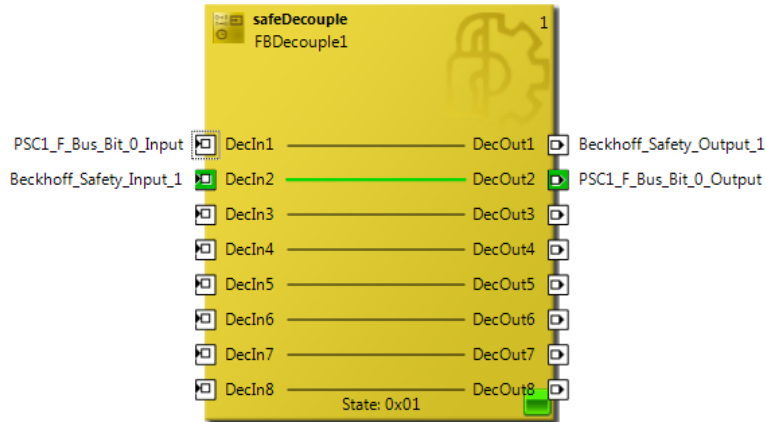

This safe information will be received from superordinate system (for example from S7)
 The Data is decoded in Bit 0 of Byte 0 (safety data block)

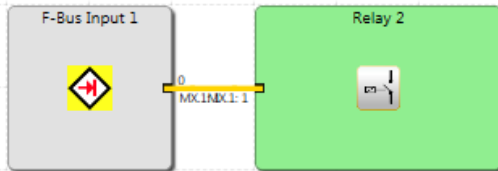

14 Commissioning and configuration PROFIBUS in SafePLC2 and TIA Portal (from Step 7 V10)

PROFIBUS is available for all PSC1 base devices with the "-FB2" option. The "-FB2" option is always permanently integrated in the base device and represents the gateway from the CAN-based backplane bus of the PSC1 series to PROFIBUS. It enables the user to exchange data bidirectionally via PROFIBUS with a higher-level controller.

In the properties of the PSC1 base device, the:

- **Local Network** - the property **fieldbus** is activated,

and in the **fieldbus properties (Fieldbus PROFIBUS)** under:

- **Type - PROFIBUS**

and under

- **Network Patterns (network prototype) - non-safe**
for non-safe data transmission

must be selected.

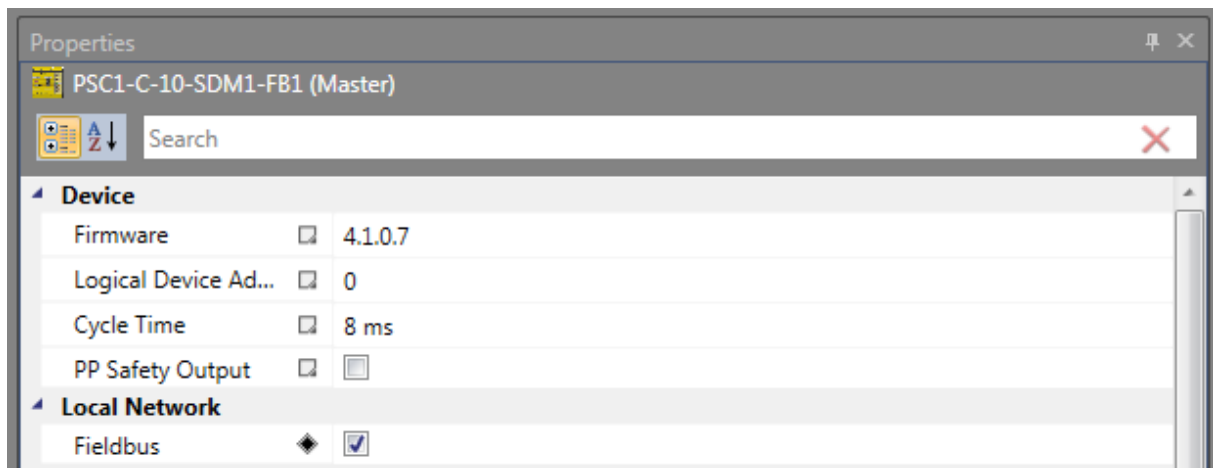

Figure 21: Properties PSC1 basic device - PROFIBUS

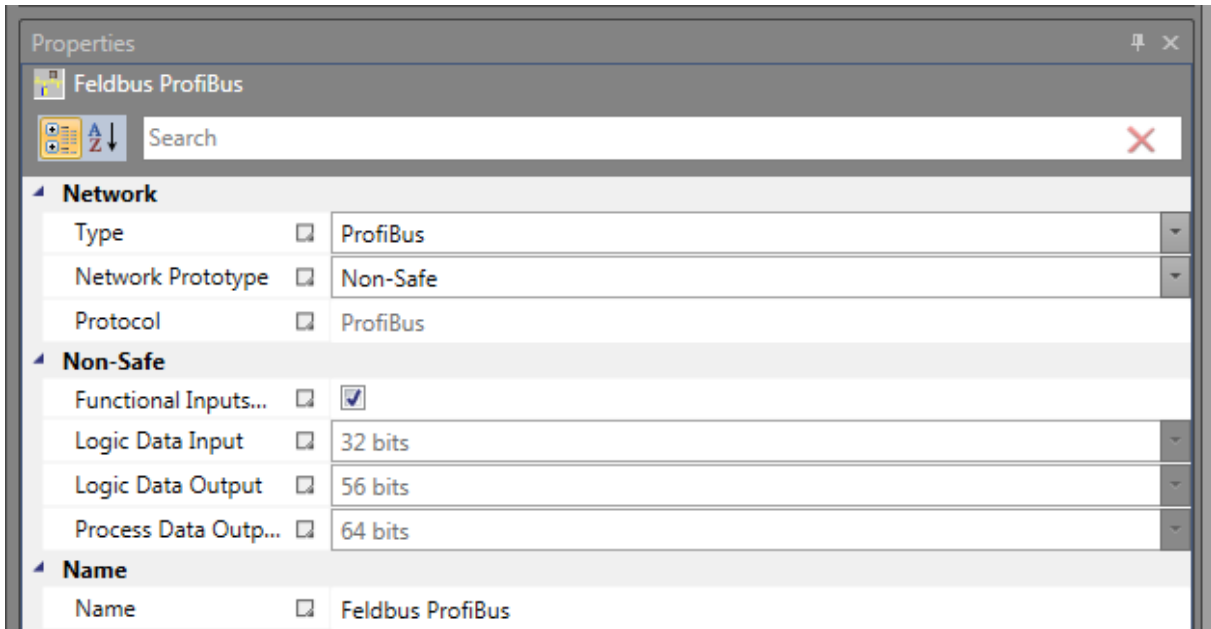

Figure 22: Properties fieldbus (Feldbus PROFIBUS) - non-safe

Parametrisation for safe data transmission (PROFIsafe)

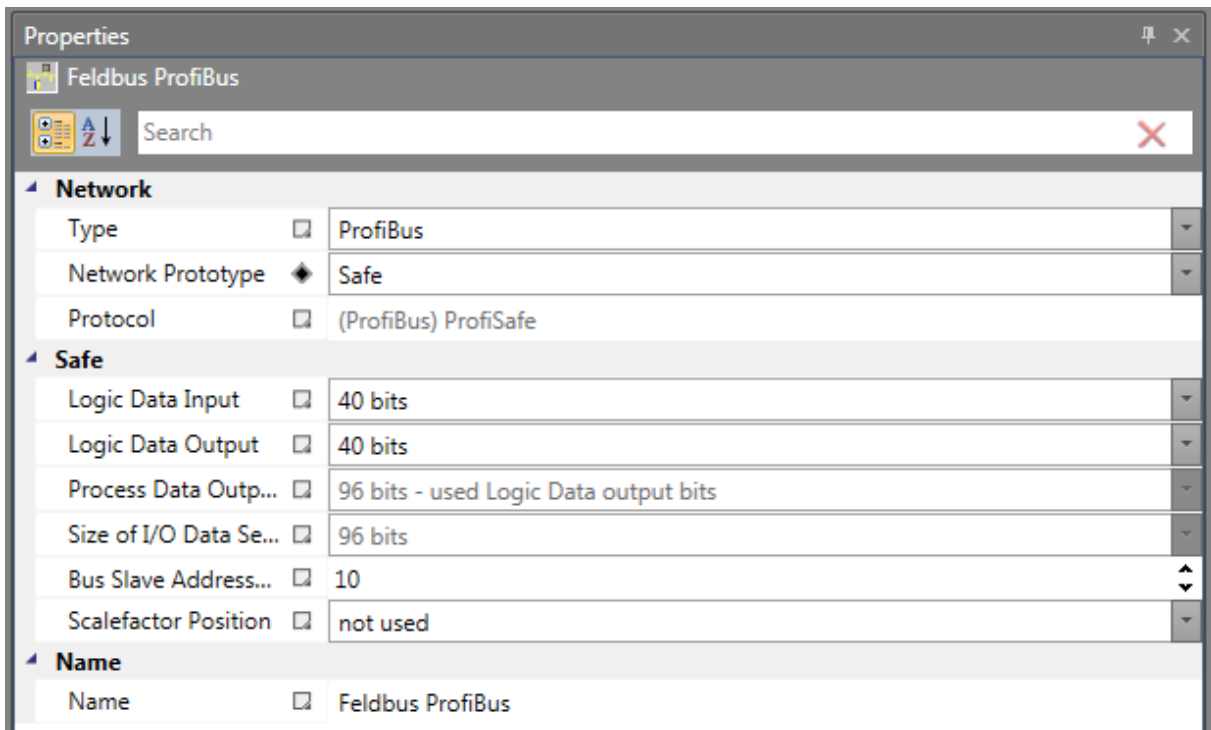

Figure 23: Properties fieldbus (Feldbus PROFIBUS) - safe

Parametrisation for non-safe and safe data transmission (PROFIsafe)

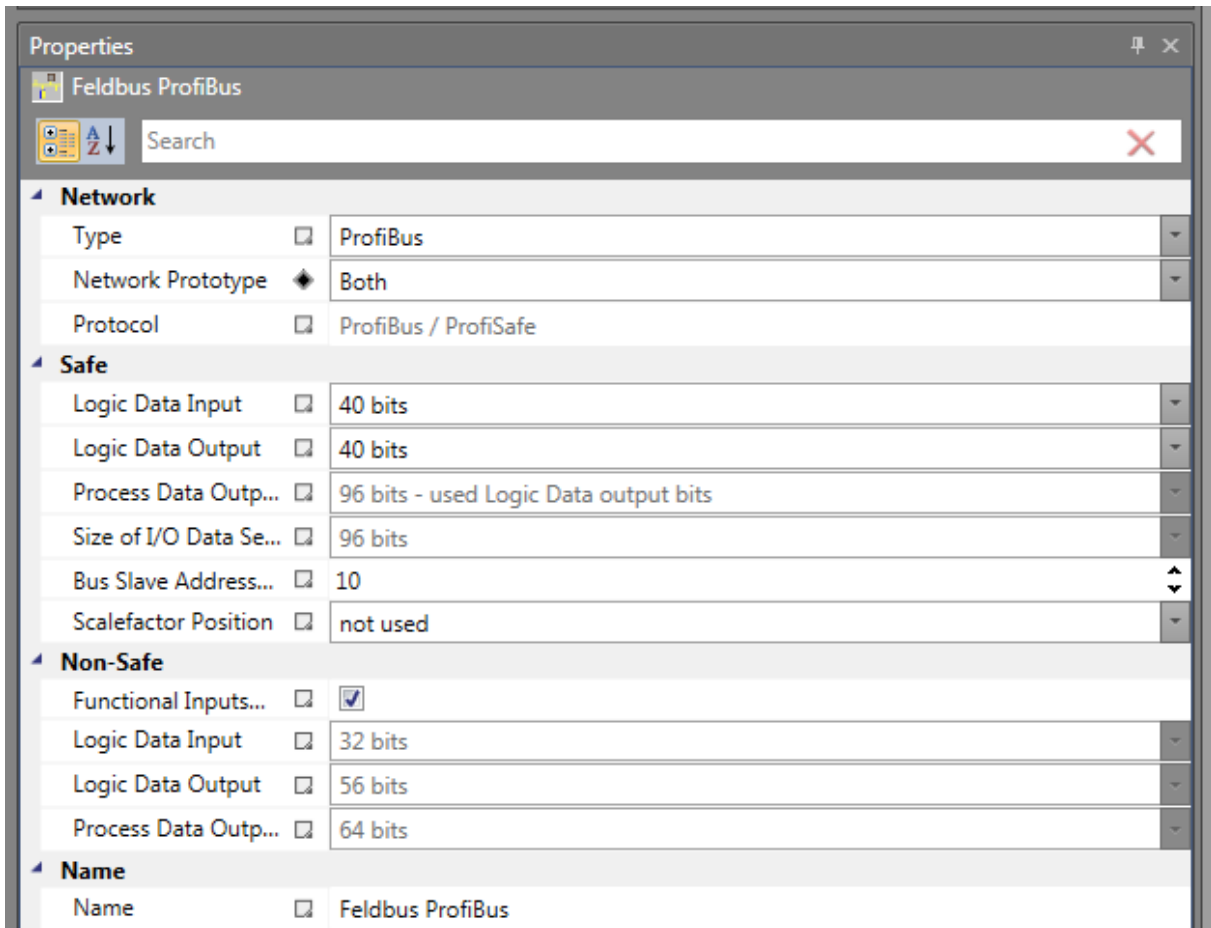
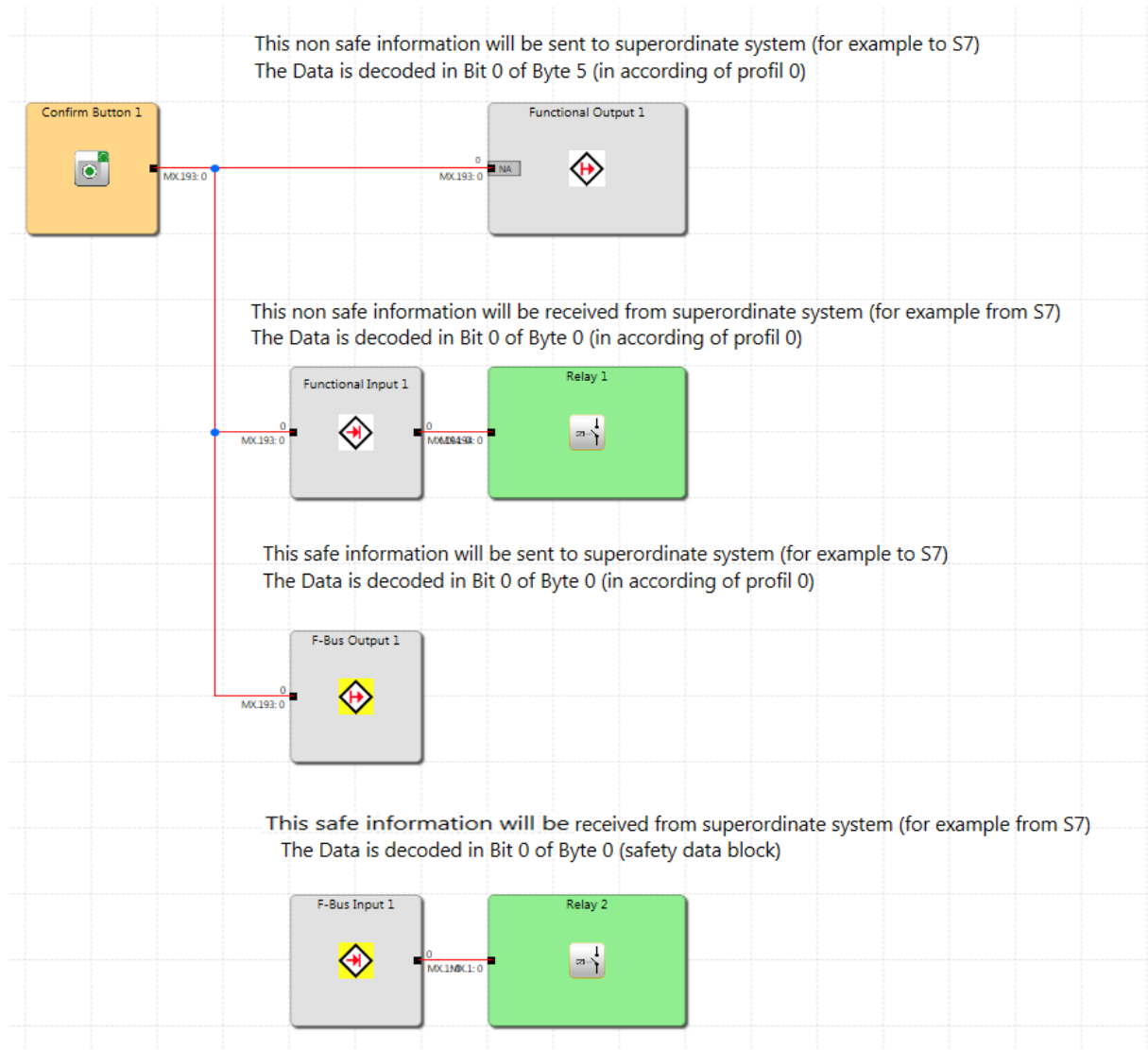

Figure 24: Properties fieldbus (Feldbus PROFIBUS) - both

The functional inputs and outputs must still be inserted in the "Functional scheme" and logically connected.



The project and the network configuration must be transferred:
"Click the "Device Interface" icon



Click the "Connect" icon in the new dialogue.

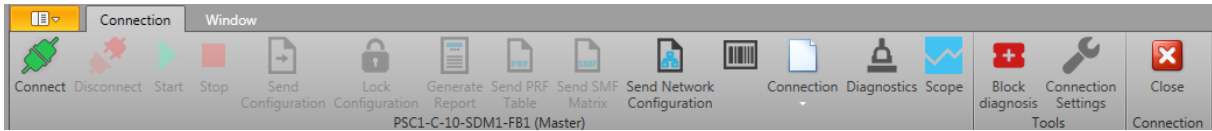

The successful connection to PSC1 is displayed in the following dialogue ("Connect icon" faded out / "Disconnect icon" faded in).

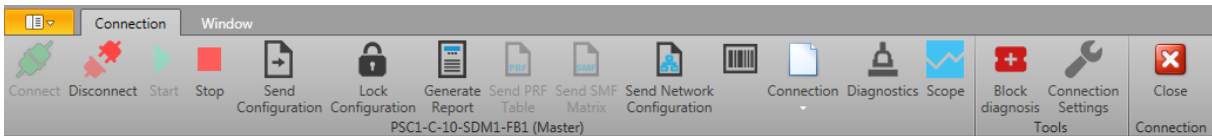

Now the network configuration and the source code can be transferred.

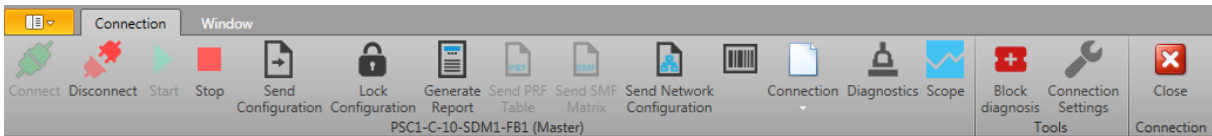

The transfer status (progress bar) is displayed in the lower information bar.

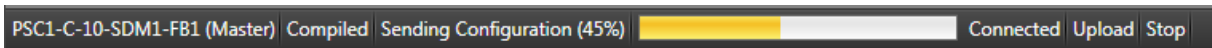

After transmission, the PSC1 may have to be restarted ("Green arrow icon").

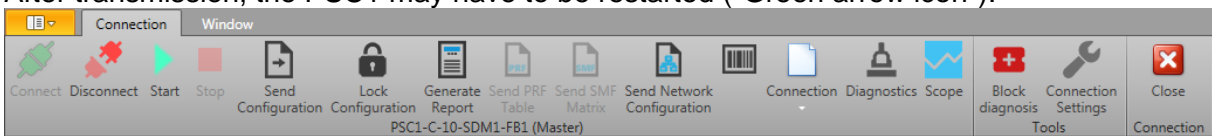

14.1 Parameter configuration

The parameters are set using the "TIA Portal" program from Siemens AG.

Installing the XML file

Click on "Tools" => "Manage device description files (GSD)".

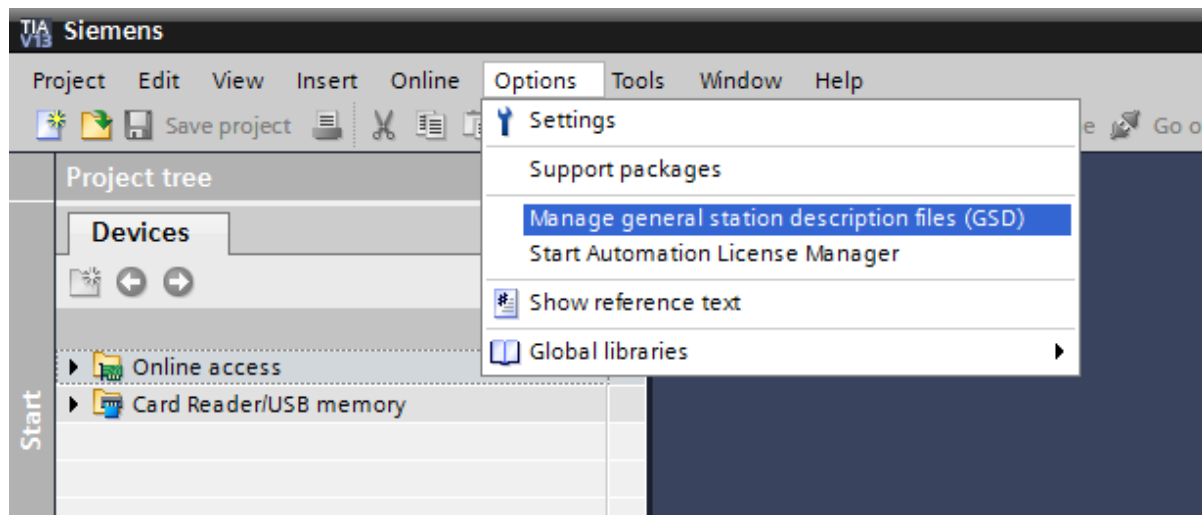

Select "Source path" and confirm the selection with "Install".

If you use the safety-related fieldbus "PROFIBUS - PROFIsafe" or carry out your project planning with TIA, please use "kas0fd5.gsd (PSC1-C-10-x-FB2 and PSC1-C-100-FB2 PROFIBUS DP-V1 extension with ProfiSAFE support.)".

If you use the non-safety-related fieldbus "PROFIBUS" and carry out your project planning with STEP7, please use "kas0fd4.gsd (PSC1-C-10-x-FB2 and PSC1-C-100-FB2 PROFIBUS DP-V1 extension)".

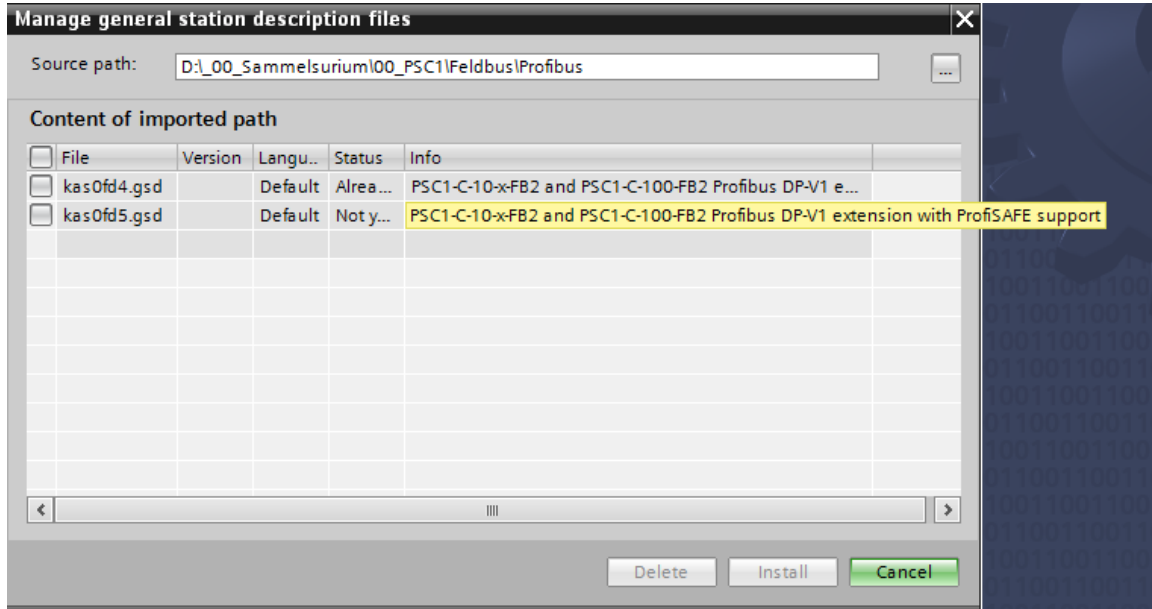

The device catalogue is updated.

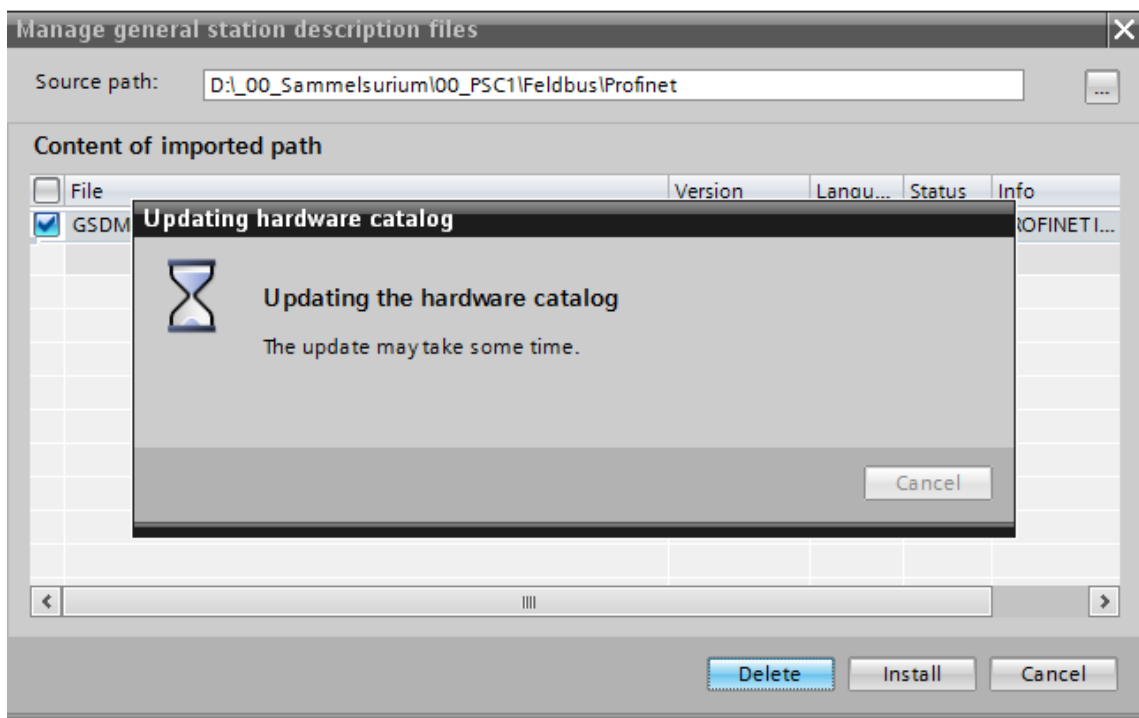

14.1.1 Create project and insert PSC1 with PROFIBUS

Create a new project with "Project" => "New".

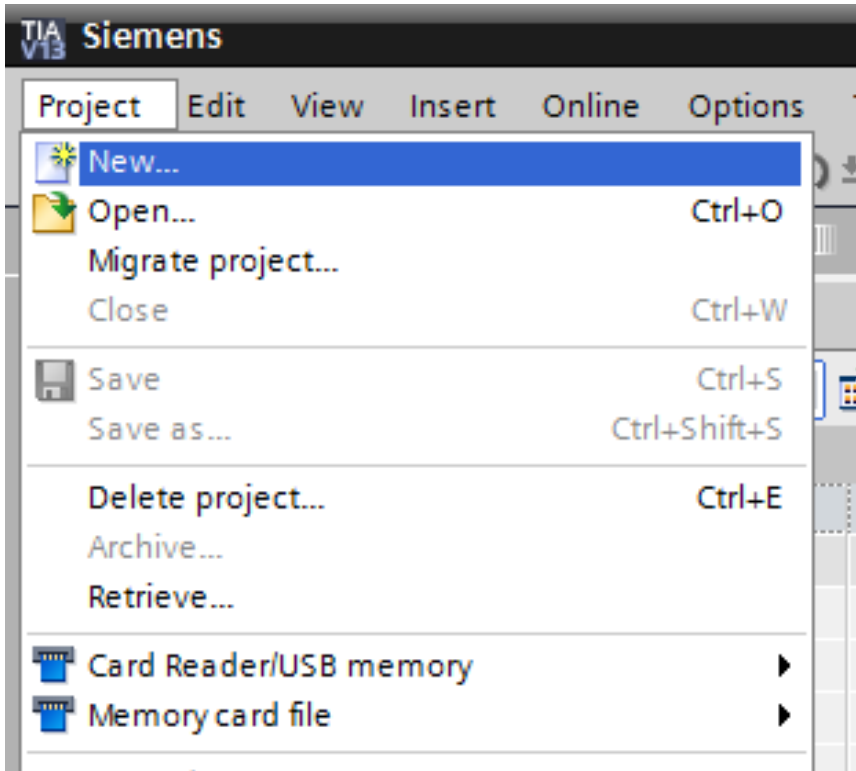

Assign a project name.

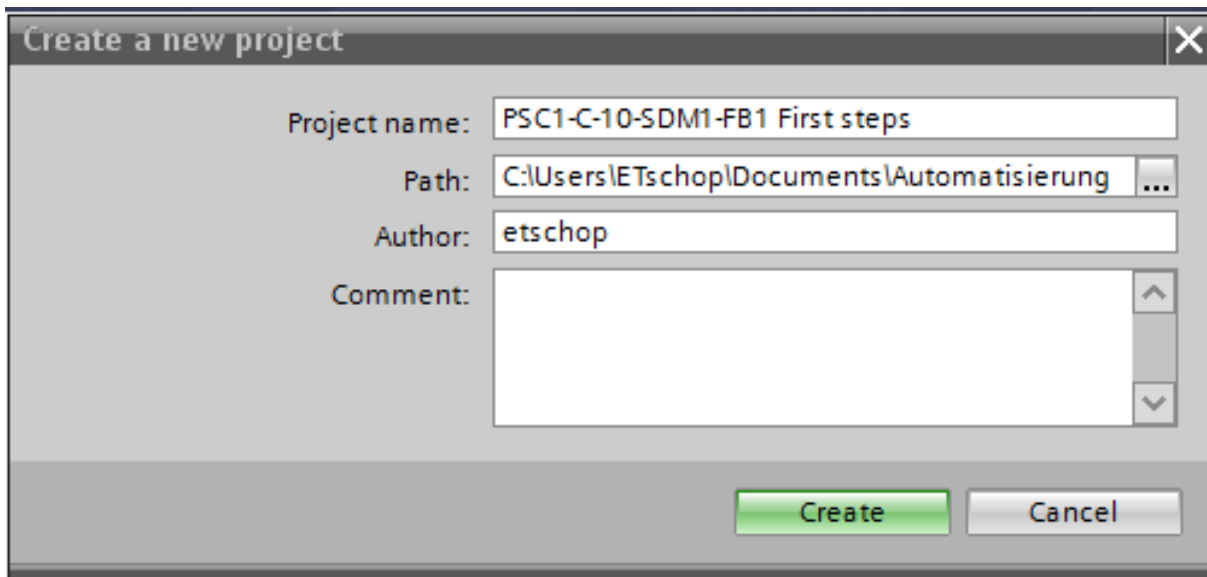

Call up the hardware catalogue in the "Network overview".

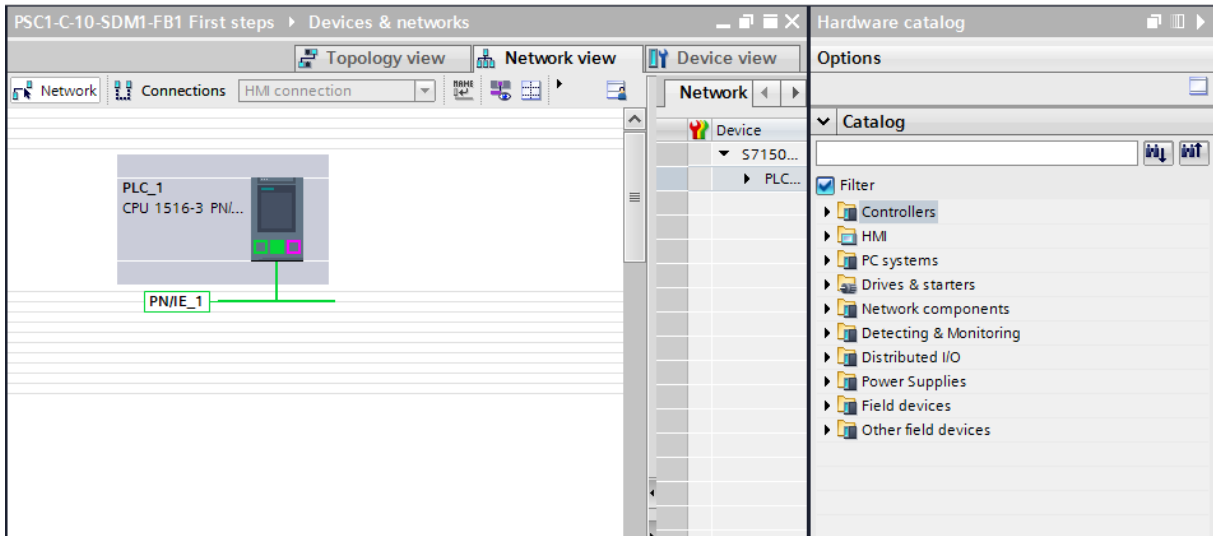

Enter "PSC1" in the search field of the hardware catalogue and confirm with "Enter".

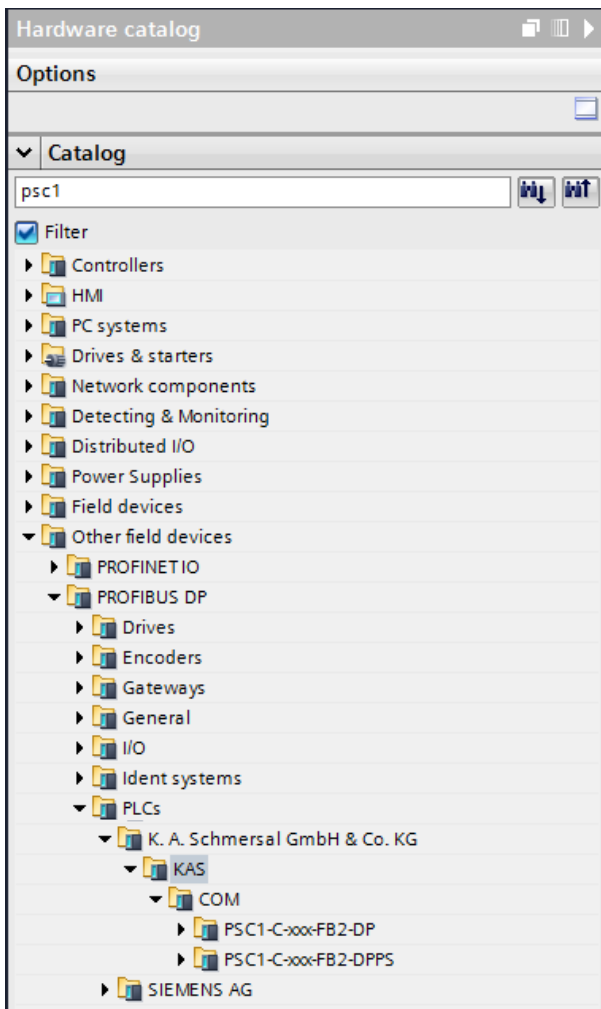

Confirm the selection by double-clicking.

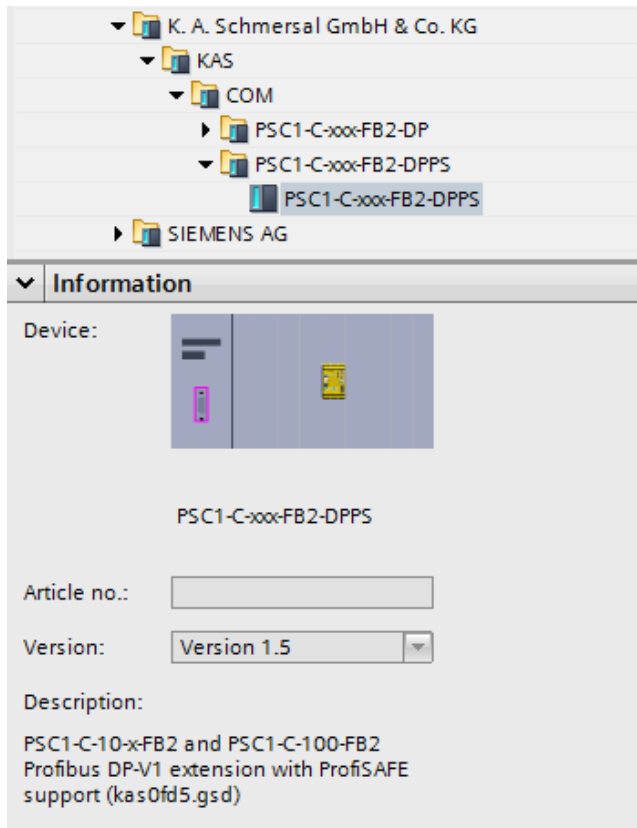

The inserted device is displayed in the "Network Overview"

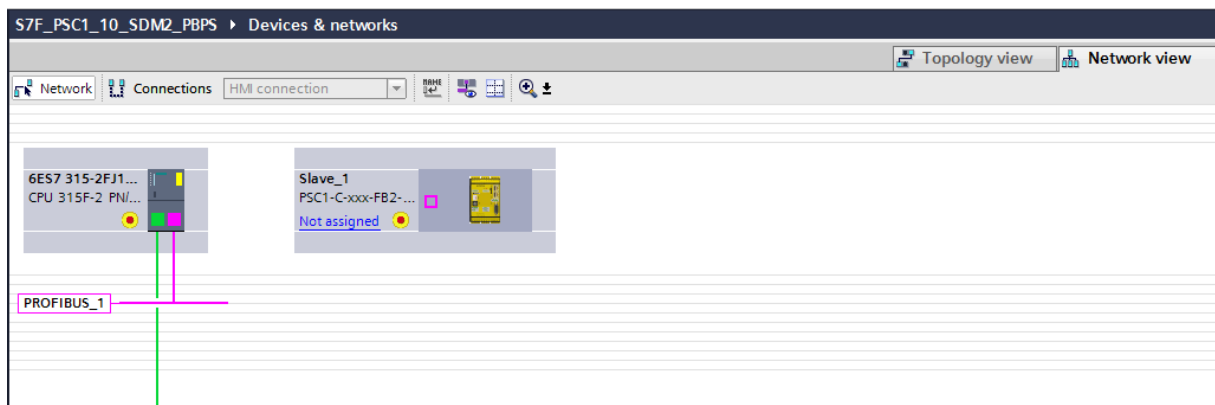

The PSC1-C-xxx-FB must still be assigned. Click on "not assigned" and select the master control.

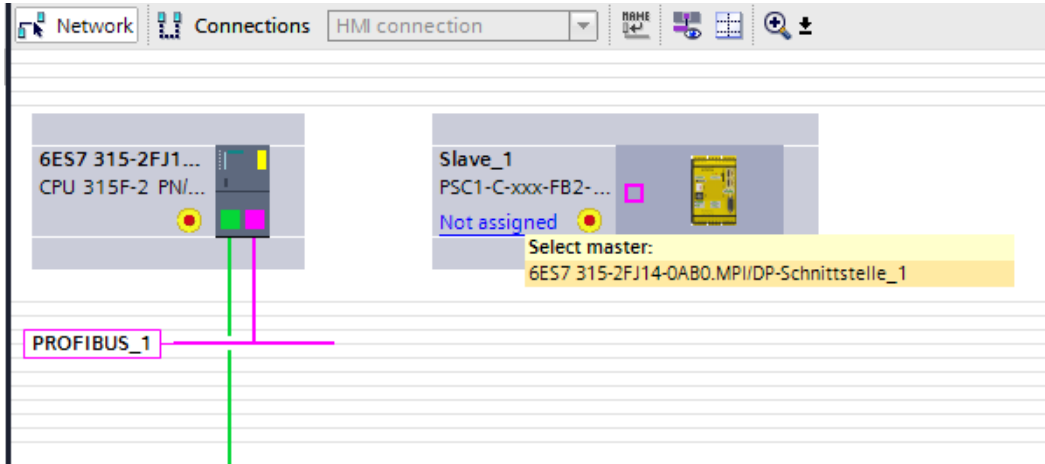

The successful assignment is indicated by a connection line

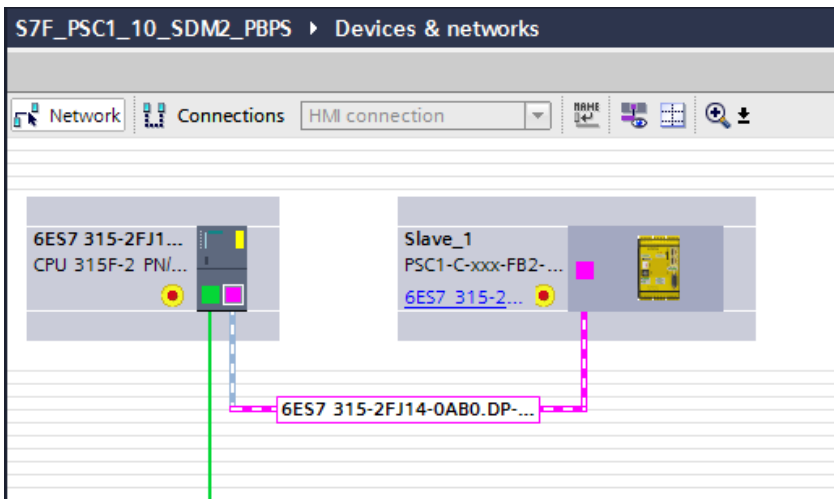

Double-click on PSC1-C-xxx-FB... to access the "Device overview".

Module	Rack	Slot	I address	Q address	Type	Article...
Slave_1	0	0	2041*		PSC1-C-xxx-FB2-DP...	
Diagnosis (16 Byte)_1	0	Diagn...	384...399		Diagnosis (16 Byte)	
Diagnosis (16 Byte)_2	0	Diagn...	400...415		Diagnosis (16 Byte)	
Diagnosis (16 Byte)_3	0	Diagn...	416...431		Diagnosis (16 Byte)	
Diagnosis (16 Byte)_4	0	Diagn...	432...447		Diagnosis (16 Byte)	
Diagnosis (16 Byte)_5	0	Diagn...	512...527		Diagnosis (16 Byte)	
Diagnosis (16 Byte)_6	0	Diagn...	528...543		Diagnosis (16 Byte)	
Diagnosis (16 Byte)_7	0	Diagn...	544...559		Diagnosis (16 Byte)	
Diagnosis (16 Byte)_8	0	Diagn...	560...575		Diagnosis (16 Byte)	
Functional Outputs_1	0			260...263	Functional Outputs	
SD Bus Input_1	0	SD Bu...	576...639		SD Bus Input	
SD Bus Output_1	0	SD Bu...		264...327	SD Bus Output	
PROFIsafe_1	0	F-Bus	28...43	28...43	PROFIsafe	

Click on the communication module to access the properties of the module.
The PSC1 PROFIBUS address must be entered in the "Address" tab.

The address entered must match the address preset on the PSC1 with the installed rotary switches

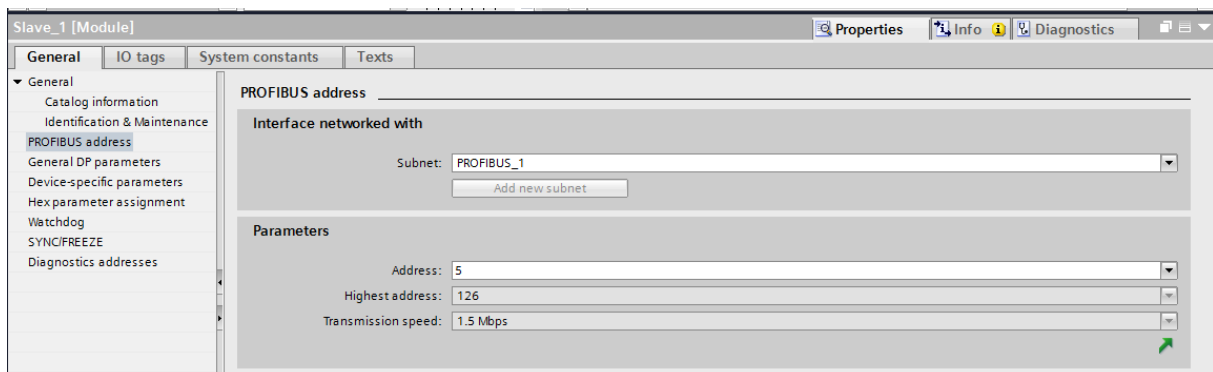

14.1.2 Setting up safe data transmission

If you do not want to set up safe data transfer, proceed with "14.1.3 Setting up non-safe data transmission".

Click on the safe communication module to access the properties of the security module.

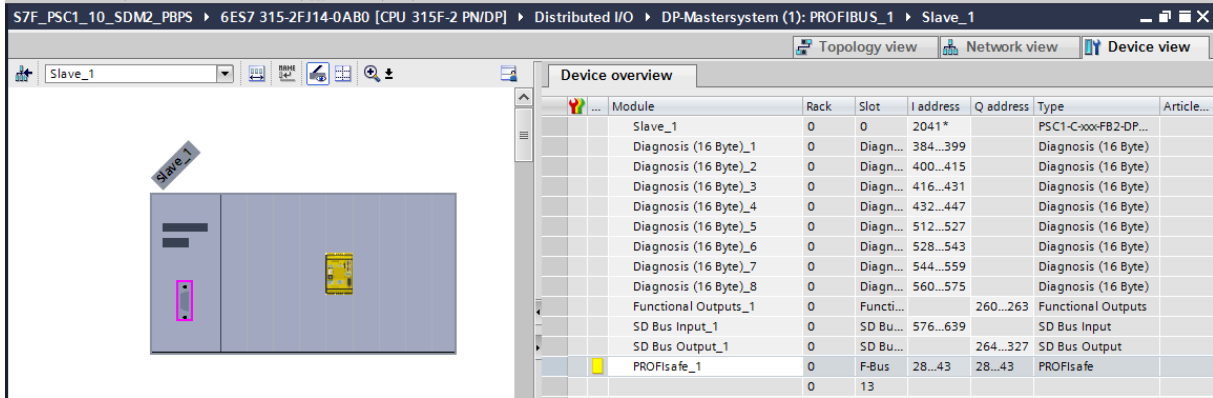

The "PROFIsafe" tab must be used to adjust the target address and the monitoring time. The destination address must correspond to the address preset in SafePLC2 (in the example the address 10).

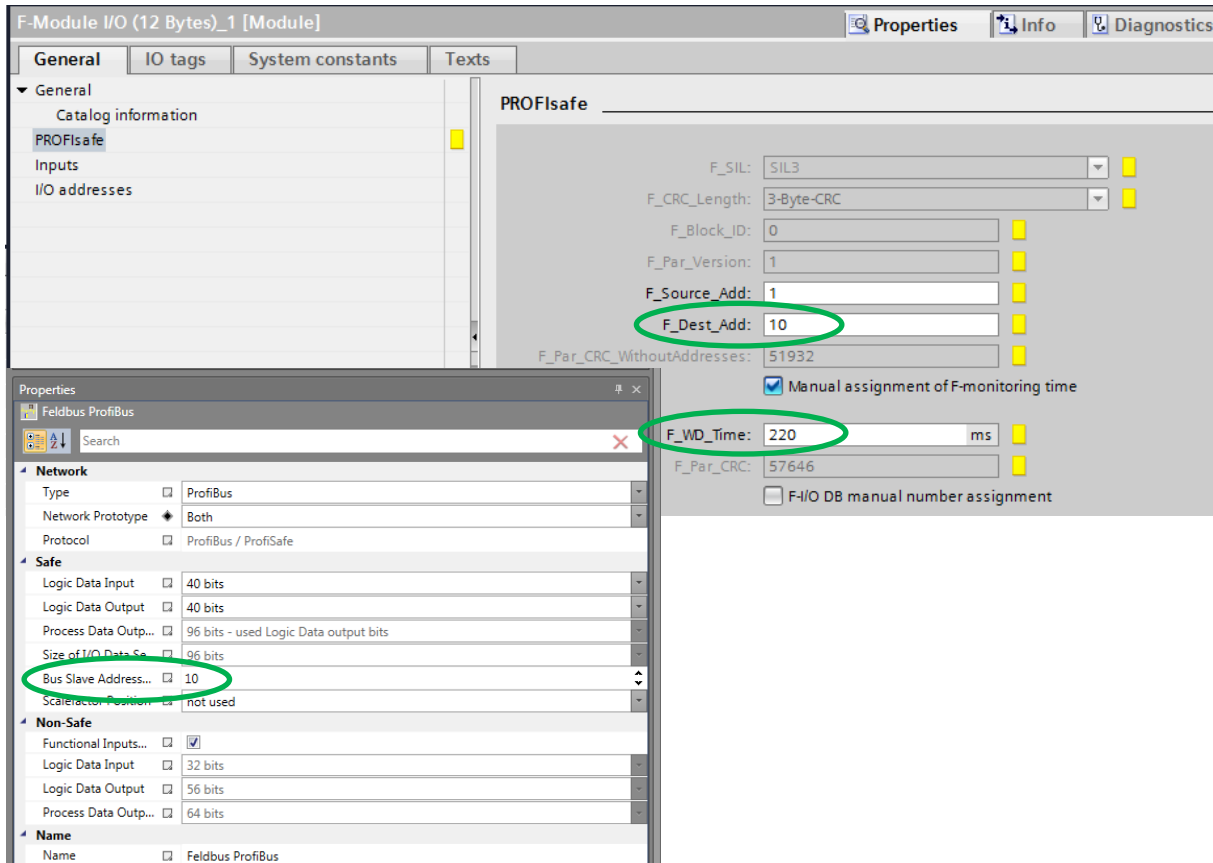

A program call must be defined in the Safety Administration Editor of the program.

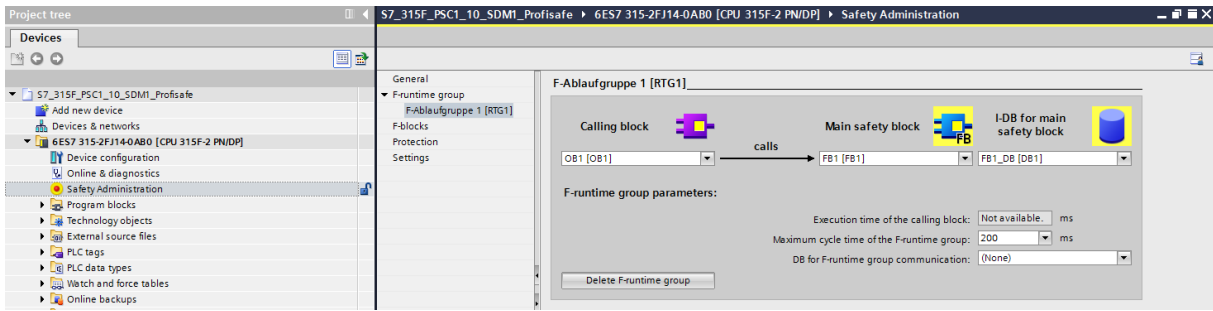

To reintegrate the safe module after an F-peripheral/channel error, an acknowledgement must still be programmed. The acknowledgement request for reintegration is detected via the variable "ACK_REQ" and the acknowledgement for reintegration is sent via the variable "ACK_REI".

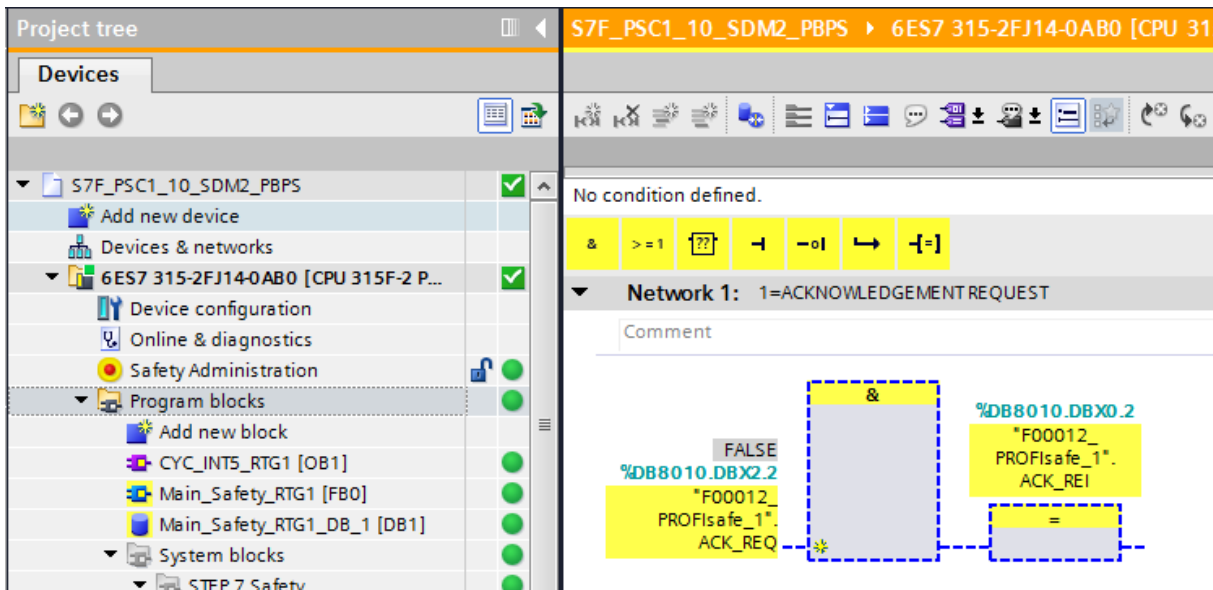

When you have finished the project planning, proceed with "14.1.4 Setting up an online connection".

14.1.3 Setting up non-safe data transmission

The following steps describe the project planning for the non-safety related PROFIBUS fieldbus.

Call up the device overview of PSC1.

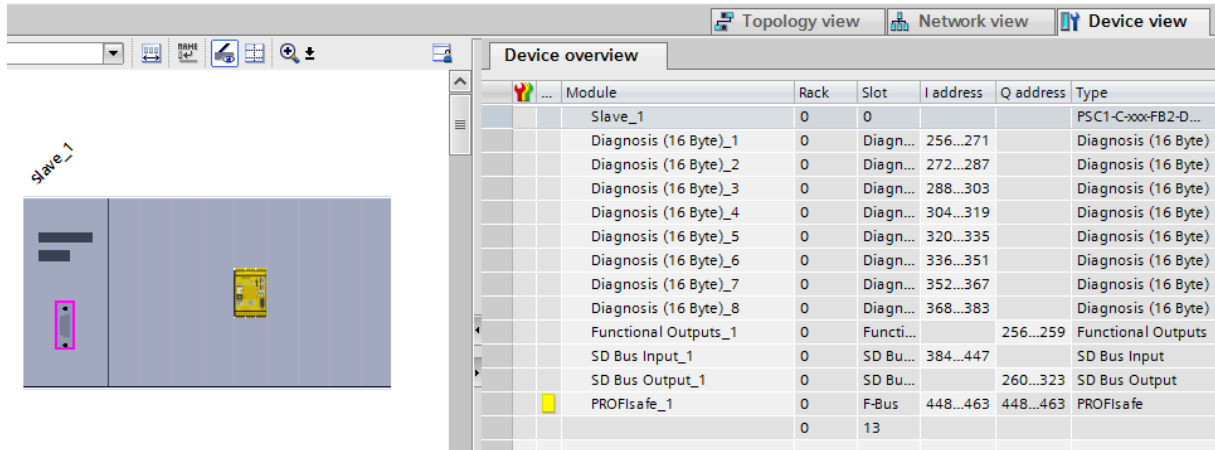

Delete the PROFIsafe_1 module.

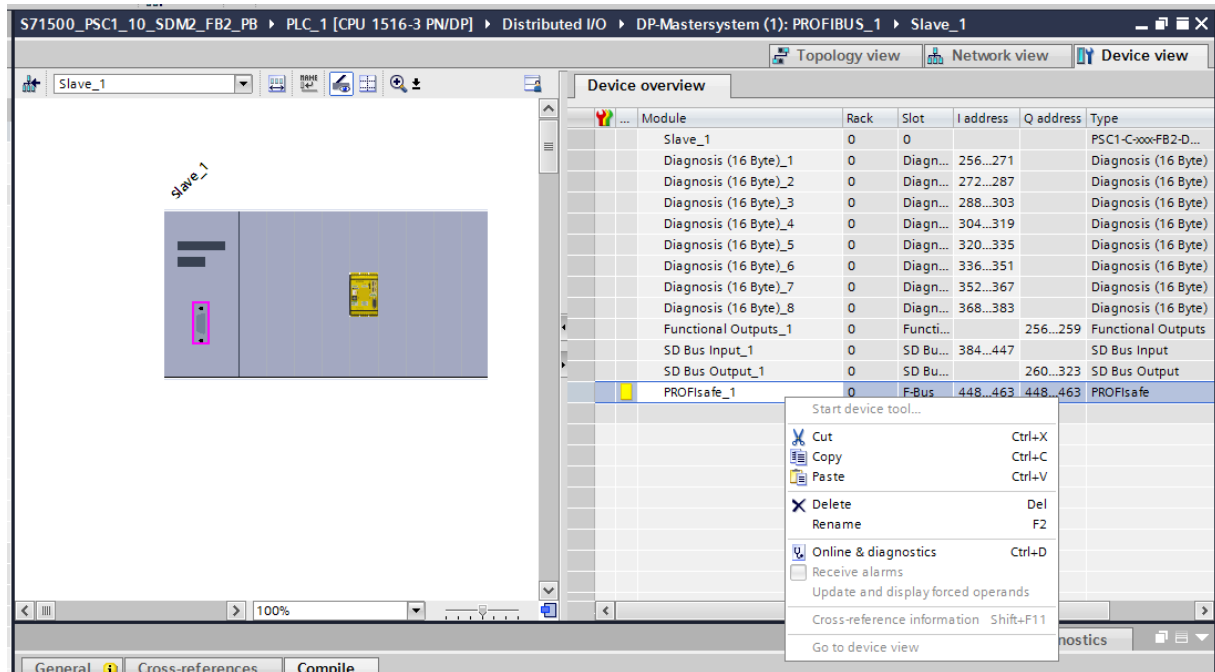

Insert an Empty Module.

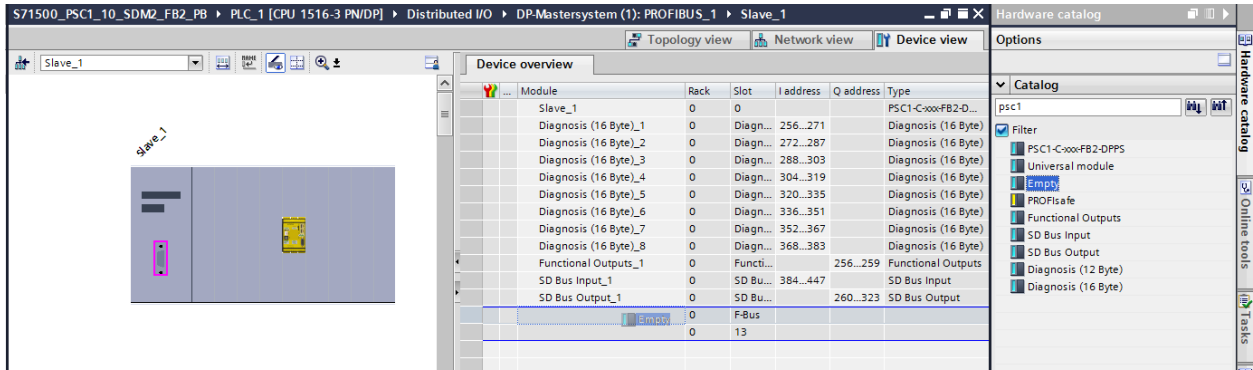

Compile the device configuration.

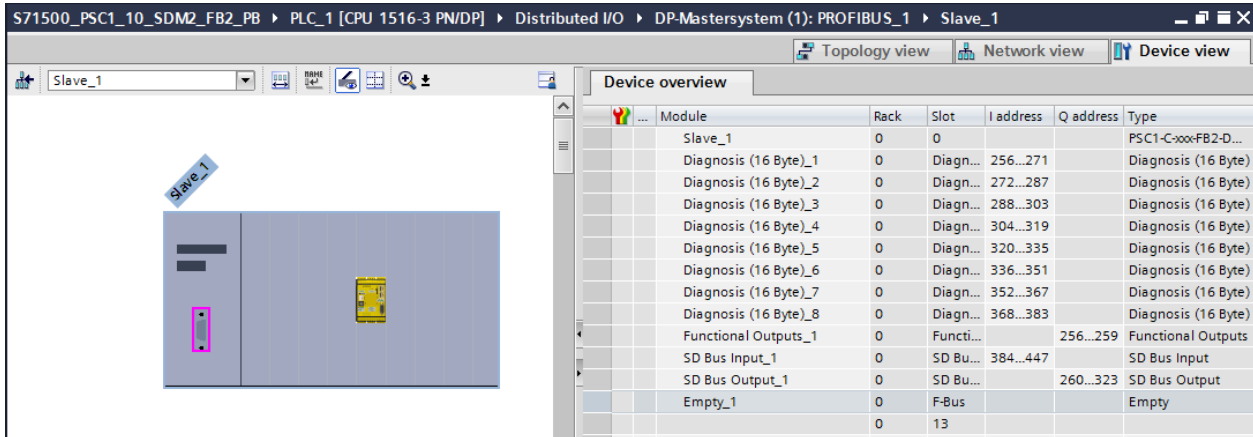

14.1.4 Setting up an online connection

To establish the online connection to the master control, you must: Click on "Connect online" and start the search for compatible devices.

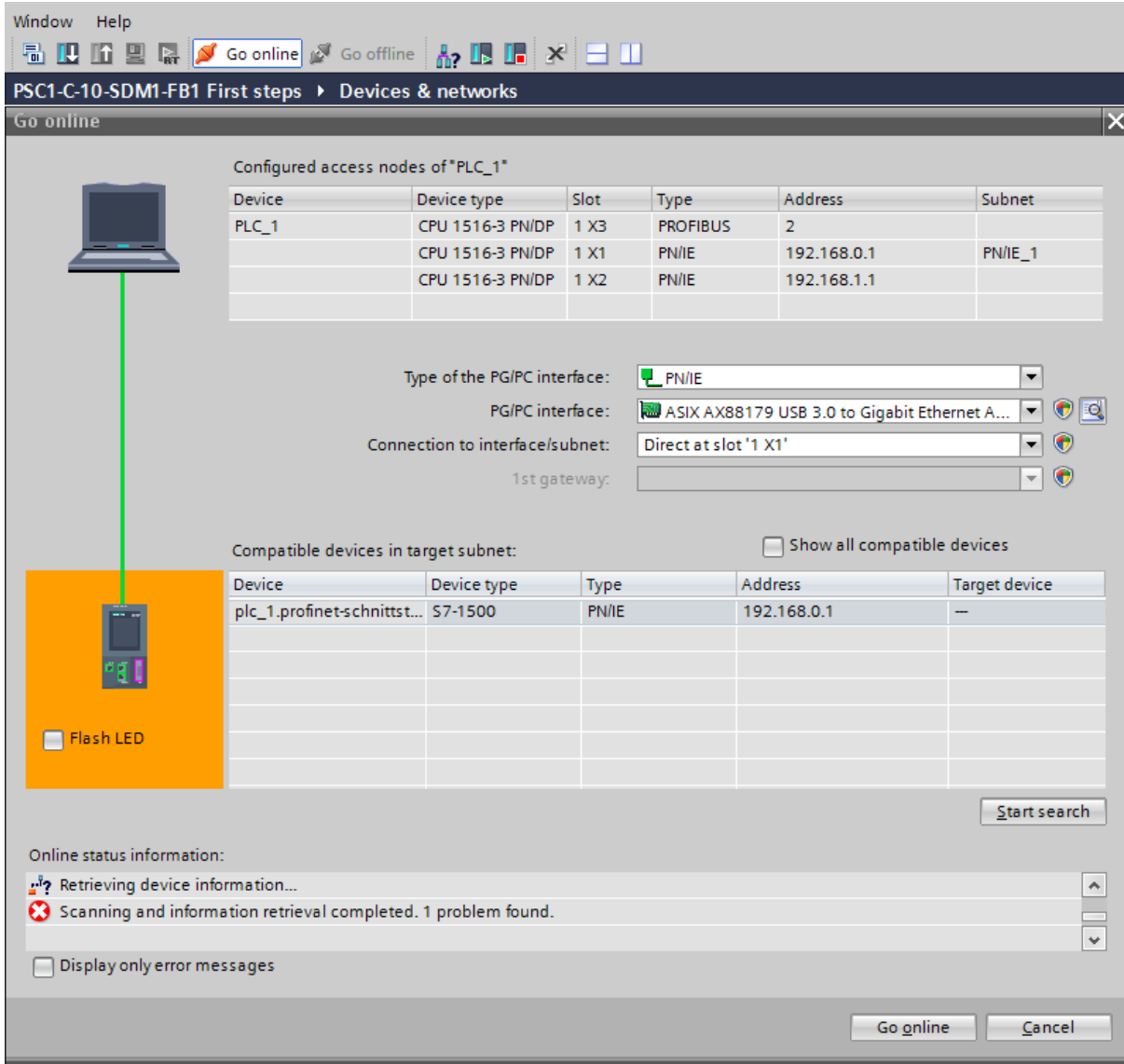

Window Help

Go online Go offline

PSC1-C-10-SDM1-FB1 First steps ▶ Devices & networks

Go online

Configured access nodes of "PLC_1"

Device	Device type	Slot	Type	Address	Subnet
PLC_1	CPU 1516-3 PN/DP	1 X3	PROFIBUS	2	
	CPU 1516-3 PN/DP	1 X1	PN/IE	192.168.0.1	PN/IE_1
	CPU 1516-3 PN/DP	1 X2	PN/IE	192.168.1.1	

Type of the PG/PC interface:

PG/PC interface:

Connection to interface/subnet:

1st gateway:

Compatible devices in target subnet: Show all compatible devices

Device	Device type	Type	Address	Target device
plc_1.profinet-schnittst...	S7-1500	PN/IE	192.168.0.1	--

Flash LED

Online status information:

- Retrieving device information...
- Scanning and information retrieval completed. 1 problem found.

Display only error messages

The IP address of the preselected communication card of the PC/PG may still have to be adapted.

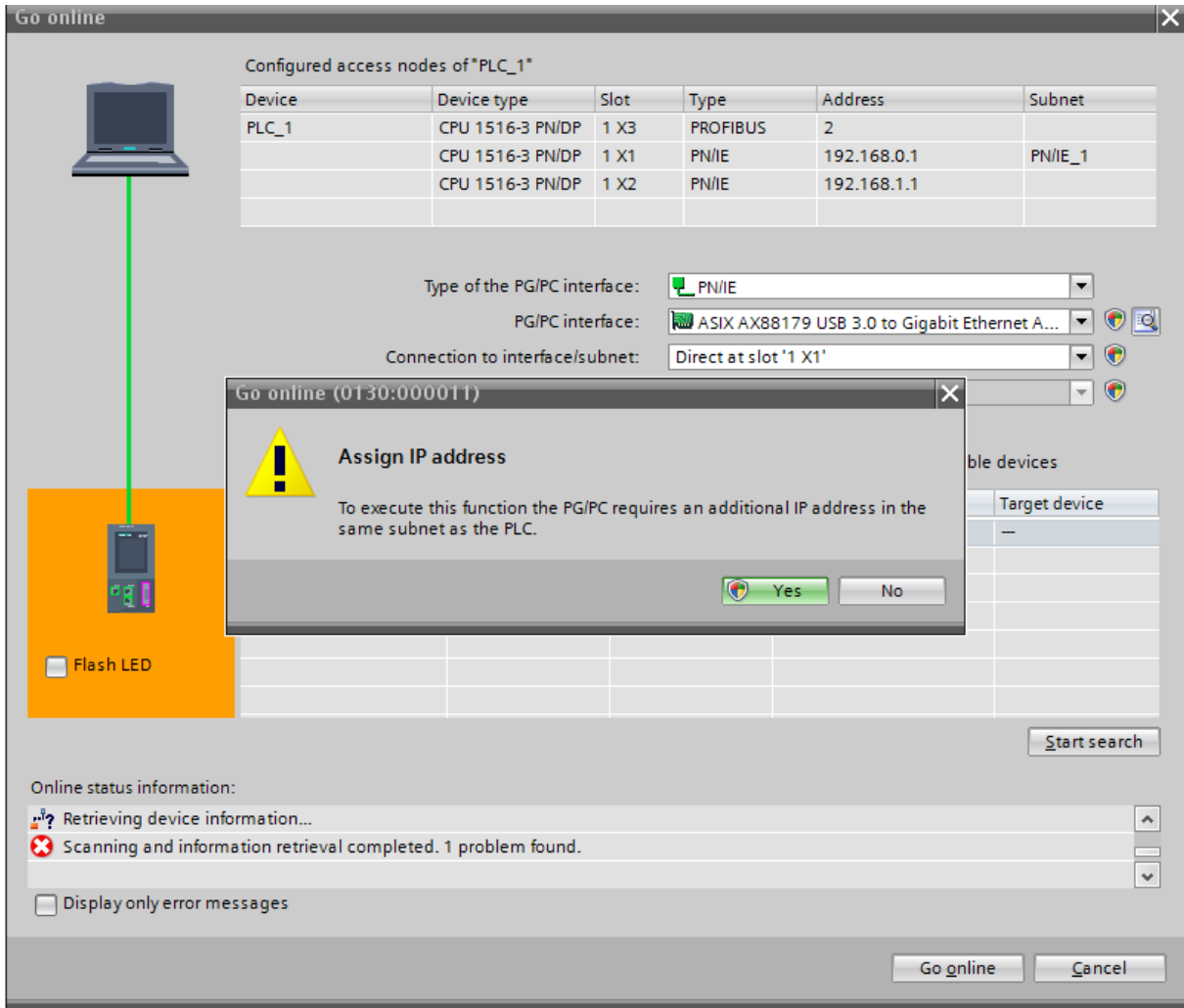

Go online
✕

Configured access nodes of *PLC_1*

Device	Device type	Slot	Type	Address	Subnet
PLC_1	CPU 1516-3 PN/DP	1 X3	PROFIBUS	2	
	CPU 1516-3 PN/DP	1 X1	PN/IE	192.168.0.1	PN/IE_1
	CPU 1516-3 PN/DP	1 X2	PN/IE	192.168.1.1	

Type of the PG/PC interface:

PG/PC interface:

Connection to interface/subnet:

Go online (0130:000008)

An additional IP address was added.

The IP address 192.168.0.241 was added to the interface ASIX AX88179 USB 3.0 to Gigabit Ethernet Adapter.

Flash LED

Start search

Online status information:

- Retrieving device information...
- Scanning and information retrieval completed. 1 problem found.

Display only error messages

Signal states can now be observed in the "Observe Variables" dialogue.

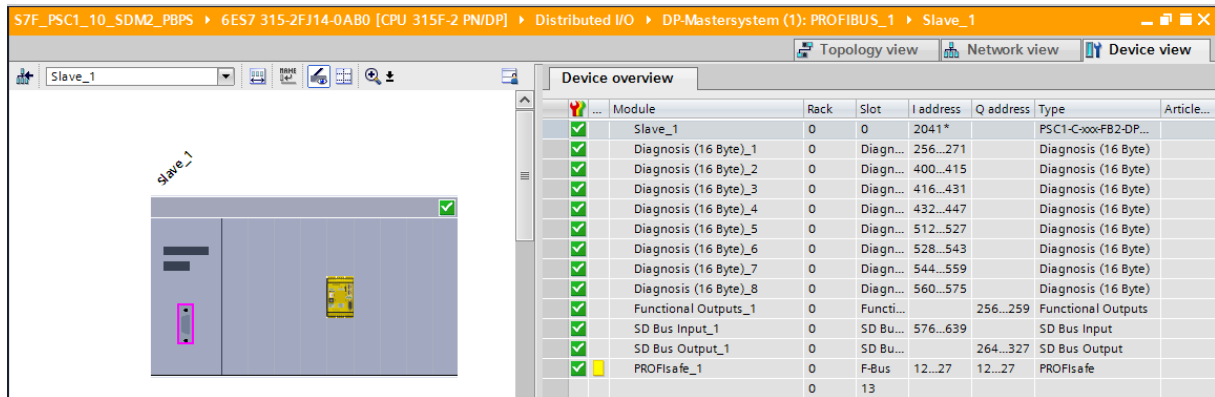

The screenshot shows the SIMATIC Manager interface with the 'Device overview' table selected. The table lists various modules for 'Slave_1' in rack 0, slot 0. The modules include diagnosis modules, functional outputs, SD bus inputs/outputs, and PROFIsafe modules.

Module	Rack	Slot	I address	Q address	Type	Article...
Slave_1	0	0	2041*		P5C1-C-xxx-FB2-DP...	
Diagnosis (16 Byte)_1	0	Diagn...	256...271		Diagnosis (16 Byte)	
Diagnosis (16 Byte)_2	0	Diagn...	400...415		Diagnosis (16 Byte)	
Diagnosis (16 Byte)_3	0	Diagn...	416...431		Diagnosis (16 Byte)	
Diagnosis (16 Byte)_4	0	Diagn...	432...447		Diagnosis (16 Byte)	
Diagnosis (16 Byte)_5	0	Diagn...	512...527		Diagnosis (16 Byte)	
Diagnosis (16 Byte)_6	0	Diagn...	528...543		Diagnosis (16 Byte)	
Diagnosis (16 Byte)_7	0	Diagn...	544...559		Diagnosis (16 Byte)	
Diagnosis (16 Byte)_8	0	Diagn...	560...575		Diagnosis (16 Byte)	
Functional Outputs_1	0	Functi...		256...259	Functional Outputs	
SD Bus Input_1	0	SD Bu...	576...639		SD Bus Input	
SD Bus Output_1	0	SD Bu...		264...327	SD Bus Output	
PROFIsafe_1	0	F-Bus	12...27	12...27	PROFIsafe	
	0	13				

14.1.5 Examples of non-safe data transmission

In the following example, the switching state of the button "Confirm Button 1" is written to SafePLC2 in bit 0 and can be read in byte 5 (bit 0) of the configuration tool (TIA).

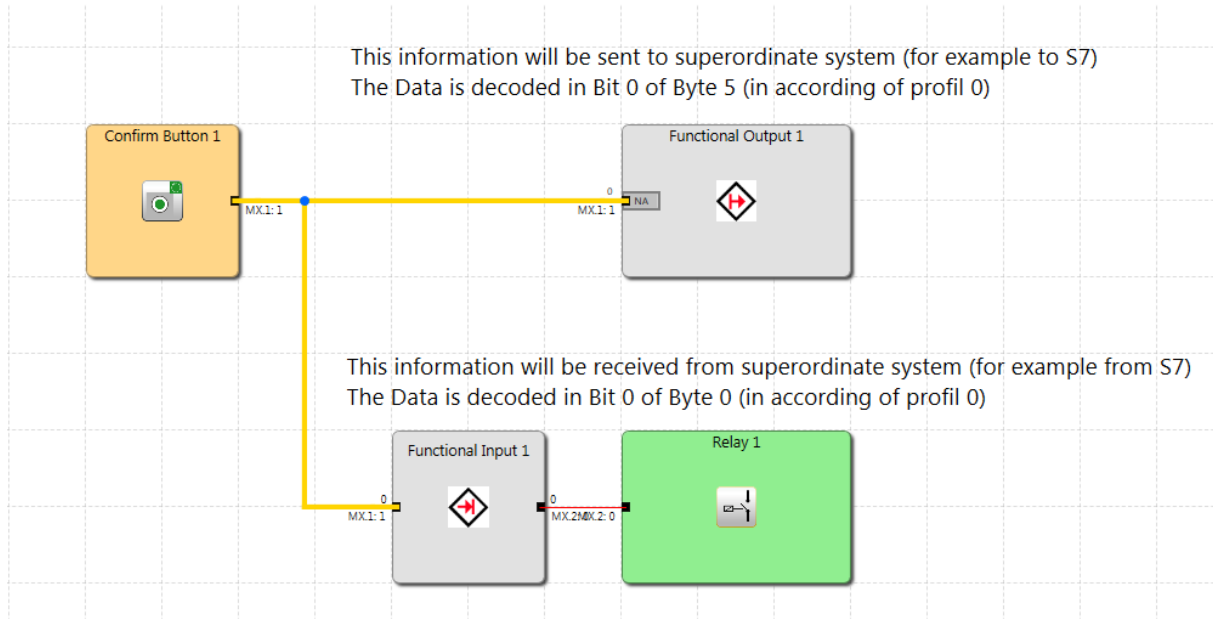

PSC1-C-10-SDM1-FB1 First steps > PLC_1 [CPU 1516-3 PN/DP] > Watch and force tables > Watch table_1

	Name	Address	Display format	Monitor value	Modify value		Comment
1	%EB256		Bin	2#0001_0100		<input type="checkbox"/>	Byte 0 // Status of PSC1 and alive counter
2	%EB257		Bin	2#0000_0000		<input type="checkbox"/>	Byte 1 // Logicdata [Bit ID 48..55]
3	%EB258		Bin	2#0000_0000		<input type="checkbox"/>	Byte 2 // Logicdata [Bit ID 40..47]
4	%EB259		Bin	2#0000_0000		<input type="checkbox"/>	Byte 3 // Logicdata [Bit ID 32..39]
5	%EB260		Bin	2#0000_0000		<input type="checkbox"/>	Byte 4 // Logicdata [Bit ID 08..15]
6	%EB261		Bin	2#0000_0011		<input type="checkbox"/>	Byte 5 // Logicdata [Bit ID 00..07]
7	%EB262		Bin	2#0000_0000		<input type="checkbox"/>	Byte 6 // Logicdata [Bit ID 24..30] +error code [high byte]
8	%EB263		Bin	2#0000_0000		<input type="checkbox"/>	Byte 7 // Logicdata [Bit ID 16..23] +error code [low byte]

In addition, up to 32 non-safe functional inputs are available on the PSC1, via which digital information can be received from the higher-level standard controller. In the "SafePLC2" function diagram, these inputs must always be AND-linked to a safe input and can then be reused as required.

In the following example, the functional output (Byte0, Bit 0) is written in the higher-level standard control and AND-linked to a safe input in PSC1 (Confirm Button 1). Both have a high signal, relay 1 is activated.

9	%AB256	Bin	2#0000_0001	2#0000_0001	<input checked="" type="checkbox"/>	Byte 1 // Functional Output [Bit ID 00..07]
10	%AB257	Bin	2#0000_0000		<input type="checkbox"/>	Byte 2 // Functional Output [Bit ID 08..15]
11	%AB258	Bin	2#0000_0000		<input type="checkbox"/>	Byte 3 // Functional Output [Bit ID 16..23]
12	%AB259	Bin	2#0000_0000		<input type="checkbox"/>	Byte 4 // Functional Output [Bit ID 24..31]

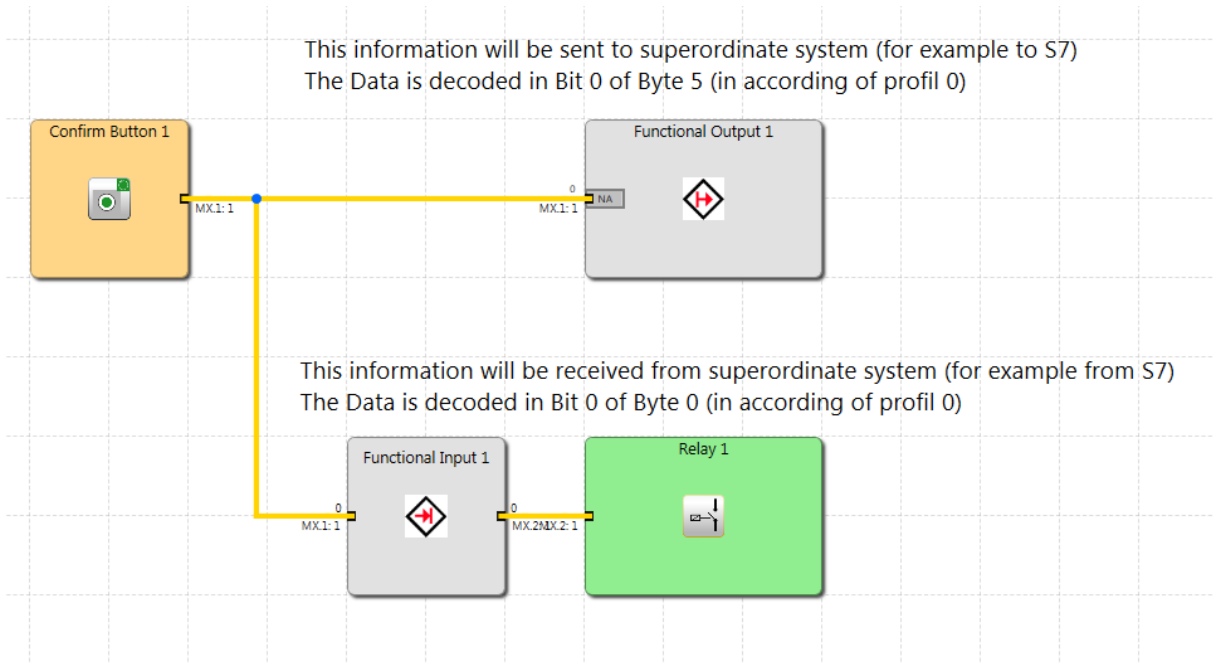

In the following example, the functional output (Byte0, Bit 0) is written in the higher-level standard control and AND-linked to a safe input in PSC1 (Confirm Button 1). "Confirm Button 1" has a low signal, the functional output from the standard control has a high signal, Relay 1 is not activated.

9	%AB256	Bin	2#0000_0001	2#0000_0001	<input checked="" type="checkbox"/>	Byte 1 // Functional Output [Bit ID 00..07]
10	%AB257	Bin	2#0000_0000		<input type="checkbox"/>	Byte 2 // Functional Output [Bit ID 08..15]
11	%AB258	Bin	2#0000_0000		<input type="checkbox"/>	Byte 3 // Functional Output [Bit ID 16..23]
12	%AB259	Bin	2#0000_0000		<input type="checkbox"/>	Byte 4 // Functional Output [Bit ID 24..31]

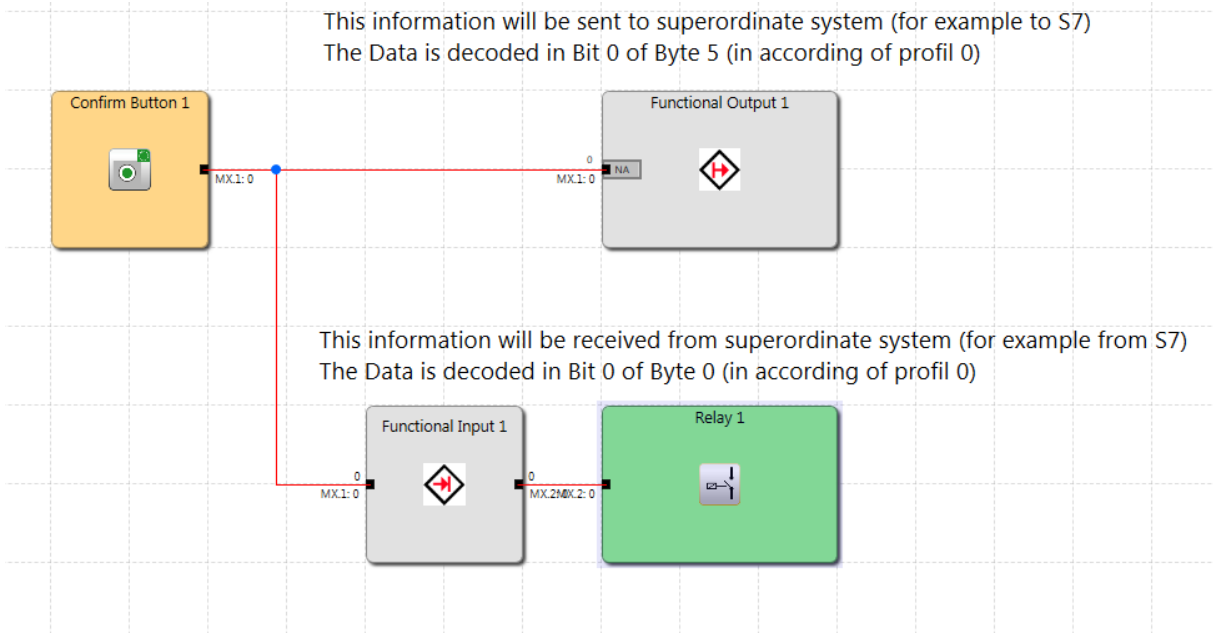

14.1.6 Examples of safe data transmission

In the following example, the switching state of the button "Confirm Button 1" is written to SafePLC2 in bit 1 (f bus output 1) and can be read in byte 0 (bit 0, F bus 00..07) of the configuration tool (TIA Portal).

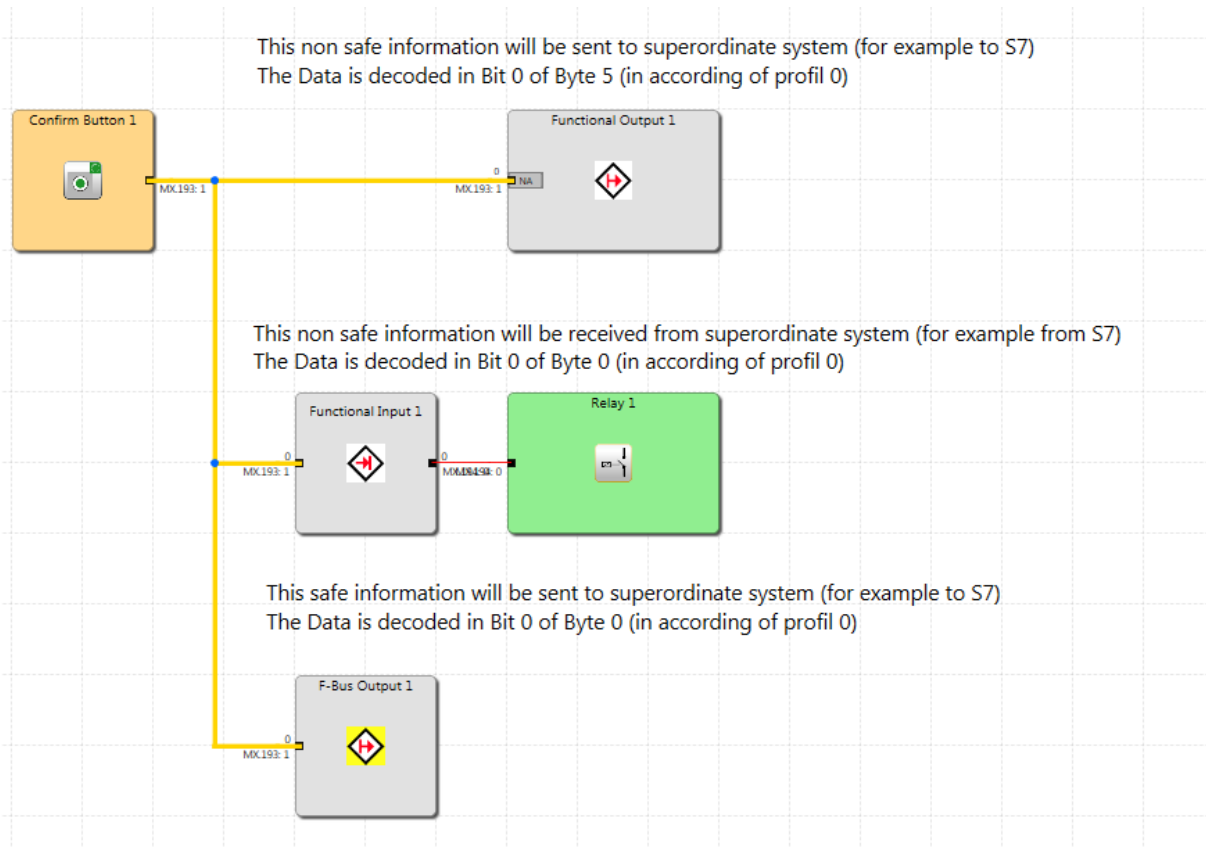

i	Name	Adresse	Anzeigeformat	Beobachtungswert	Steuerwert	⚡
1	*F-Bus 00..07*	%EB12	Bin	2#0000_0001		<input type="checkbox"/>
2	*F-Bus IN 08..15*	%EB13	Bin	2#0000_0000		<input type="checkbox"/>
3	*F-Bus IN 16..23*	%EB14	Bin	2#0000_0000		<input type="checkbox"/>
4	*F-Bus IN 24..32*	%EB15	Bin	2#0000_0000		<input type="checkbox"/>
5	*F-Bus IN 32..39*	%EB16	Bin	2#0000_0000		<input type="checkbox"/>
6	*F-Bus IN 40..47*	%EB17	Bin	2#0000_0000		<input type="checkbox"/>
7	*F-Bus IN 48..55*	%EB18	Bin	2#0000_0000		<input type="checkbox"/>
8	*F-Bus IN 56..63*	%EB19	Bin	2#0000_0000		<input type="checkbox"/>
9	*F-Bus IN 64..71*	%EB20	Bin	2#0000_0000		<input type="checkbox"/>
10	*F-Bus IN 72..79*	%EB21	Bin	2#0000_0000		<input type="checkbox"/>
11	*F-Bus IN 80..88*	%EB22	Bin	2#0000_0000		<input type="checkbox"/>
12	*F-Bus IN 89..96*	%EB23	Bin	2#0000_0000		<input type="checkbox"/>
13	*F-Bus CRC Byte 1*	%EB24	Hex	16#20		<input type="checkbox"/>
14	*F-Bus CRC Byte 2*	%EB25	Hex	16#69		<input type="checkbox"/>
15	*F-Bus CRC Byte 3*	%EB26	Hex	16#1A		<input type="checkbox"/>
16	*F-Bus CRC Byte 4*	%EB27	Hex	16#04		<input type="checkbox"/>

The last four bytes are intended for CRC control.

14.1.7 Examples of safe data transmission

In the following example, the switching state of the button "Confirm Button 1" is written to PSC1 in bit 1 (f bus output 1) and can be read in byte 0 (bit 0, F bus 00..07) of the configuration tool (TIA Portal).

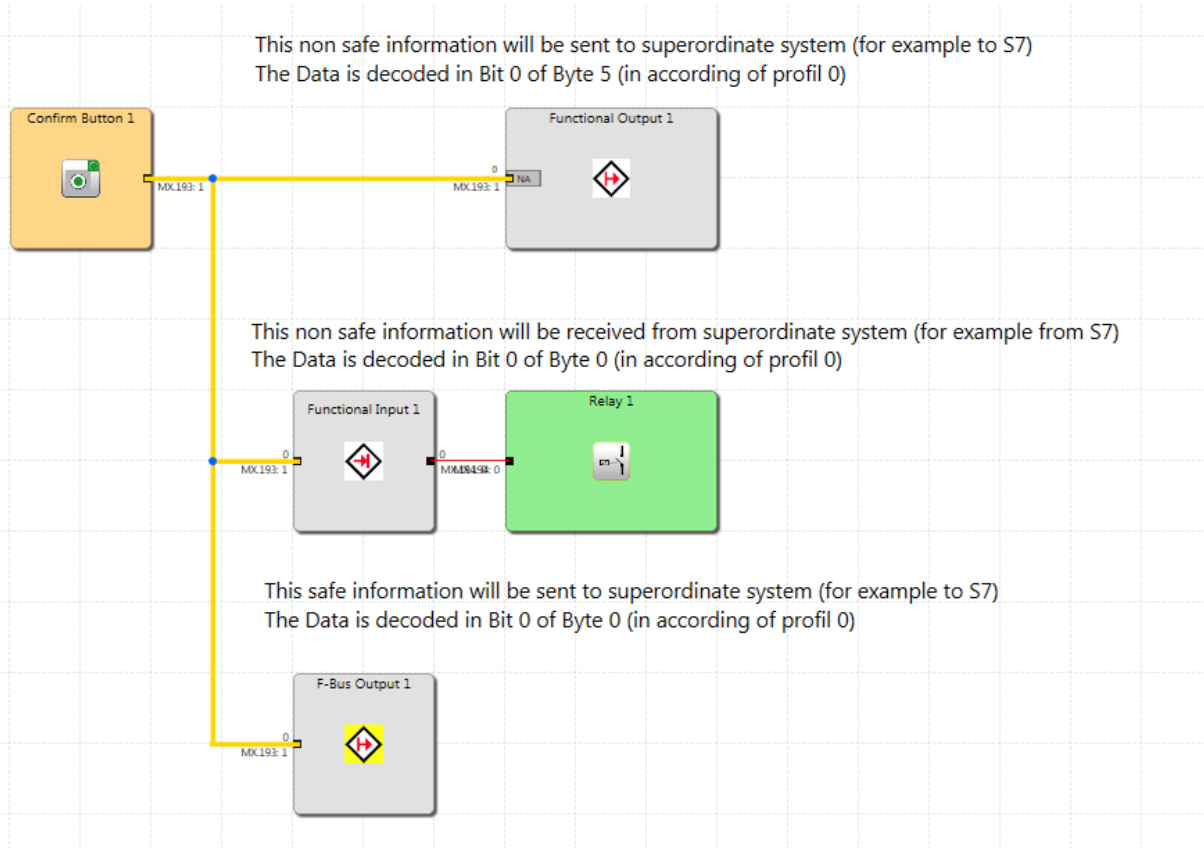

i	Name	Adresse	Anzeigeformat	Beobachtungswert	Steuerwert	⚡
1	*F-Bus 00..07*	%EB12	Bin	2#0000_0001		<input type="checkbox"/>
2	*F-Bus IN 08..15*	%EB13	Bin	2#0000_0000		<input type="checkbox"/>
3	*F-Bus IN 16..23*	%EB14	Bin	2#0000_0000		<input type="checkbox"/>
4	*F-Bus IN 24..32*	%EB15	Bin	2#0000_0000		<input type="checkbox"/>
5	*F-Bus IN 32..39*	%EB16	Bin	2#0000_0000		<input type="checkbox"/>
6	*F-Bus IN 40..47*	%EB17	Bin	2#0000_0000		<input type="checkbox"/>
7	*F-Bus IN 48..55*	%EB18	Bin	2#0000_0000		<input type="checkbox"/>
8	*F-Bus IN 56..63*	%EB19	Bin	2#0000_0000		<input type="checkbox"/>
9	*F-Bus IN 64..71*	%EB20	Bin	2#0000_0000		<input type="checkbox"/>
10	*F-Bus IN 72..79*	%EB21	Bin	2#0000_0000		<input type="checkbox"/>
11	*F-Bus IN 80..88*	%EB22	Bin	2#0000_0000		<input type="checkbox"/>
12	*F-Bus IN 89..96*	%EB23	Bin	2#0000_0000		<input type="checkbox"/>
13	*F-Bus CRC Byte 1*	%EB24	Hex	16#20		<input type="checkbox"/>
14	*F-Bus CRC Byte 2*	%EB25	Hex	16#69		<input type="checkbox"/>
15	*F-Bus CRC Byte 3*	%EB26	Hex	16#1A		<input type="checkbox"/>
16	*F-Bus CRC Byte 4*	%EB27	Hex	16#04		<input type="checkbox"/>

The last four bytes are intended for CRC control.

In addition, up to 96 safe functional inputs are available on the PSC1, via which digital information can be received by the higher-level safety controller.

In the following example, the functional output (F_Bus byte 0. bit 0) is written in the safety controller and read in the PSC1 in bit 0 (F bus input 1).

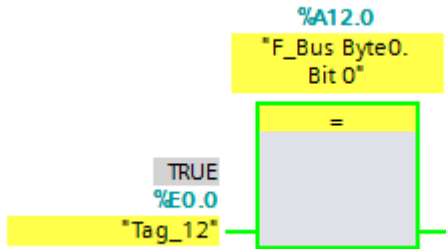

17	"F-Bus OUT 00..07"	%AB12	Bin	2#0000_0001
----	--------------------	-------	-----	-------------

This safe information will be received from superordinate system (for example from S7)
 The Data is decoded in Bit 0 of Byte 0 (safety data block)

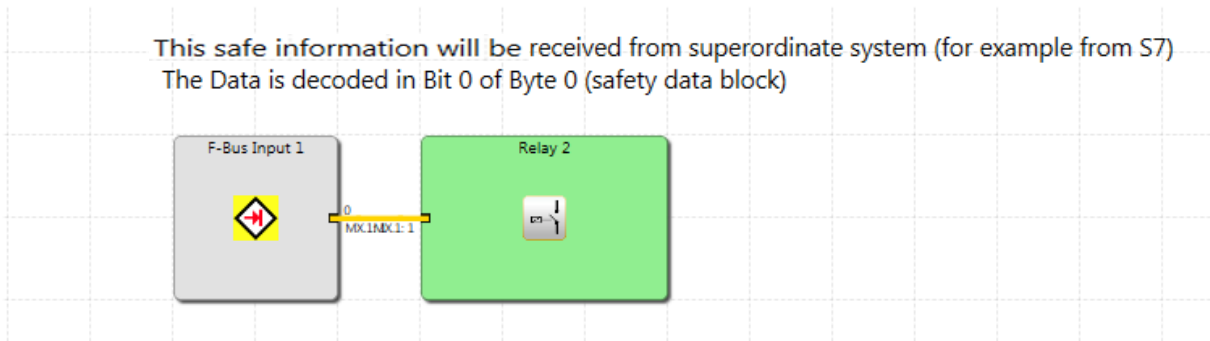

15 Commissioning and configuration CANopen in SafePLC2 and Codesys

CANopen is available for all PSC1 base devices (starting from COM-Firmware release 1.8.1) with the "-FB2" option. The "-FB2" option is always permanently integrated in the base device and represents the gateway from the CAN-based backplane bus of the PSC1 series to CANopen.

It enables the user to exchange data bidirectionally via CANopen with a higher-level controller.

In the properties of the PSC1 base device:

- **Local Network** - the property **Fieldbus** must be activated,...

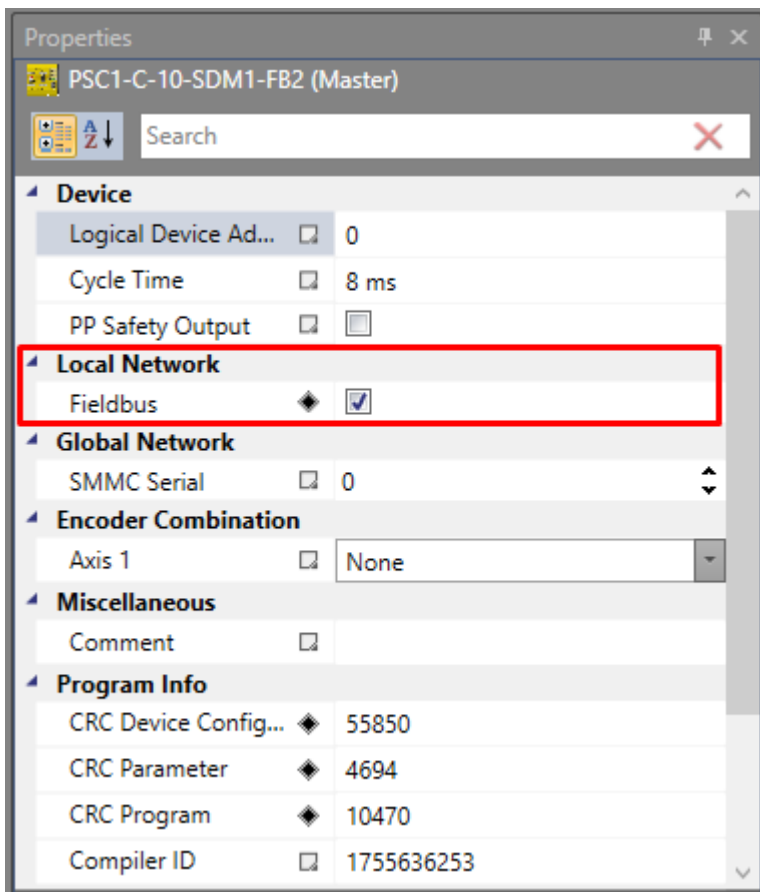

...and in the **fieldbus properties**

- **Type - CANOPEN**

must be selected.

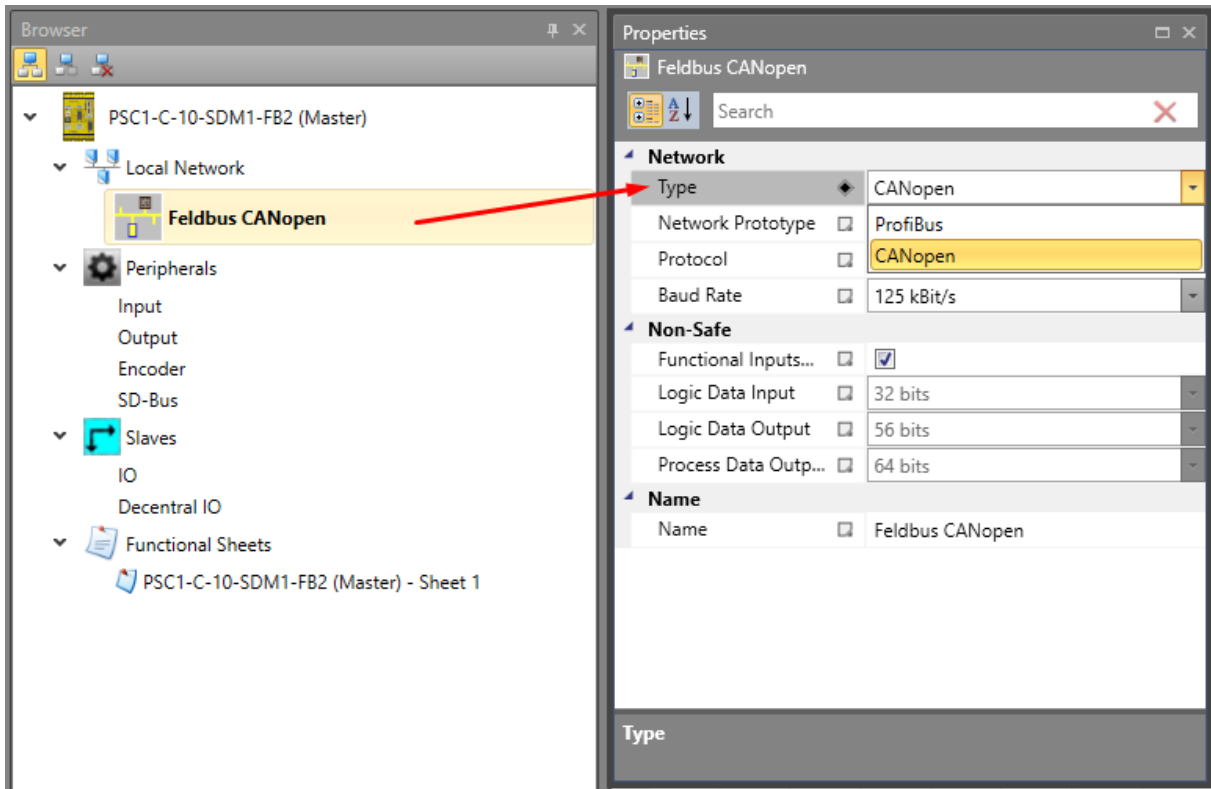

This configuration is then transferred via

Device Interface -> Connect -> Send Network Configuration

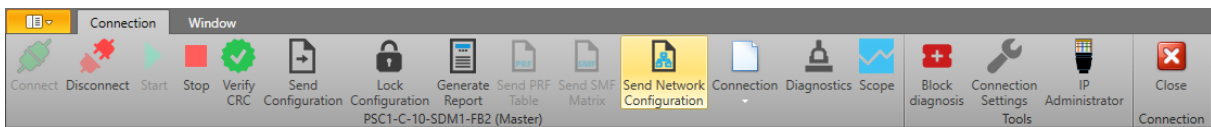

to the device.

The following section shows an example of commissioning a PSC1 with CANopen interface in a Codesys setting.

15.1 Integrating the device description file

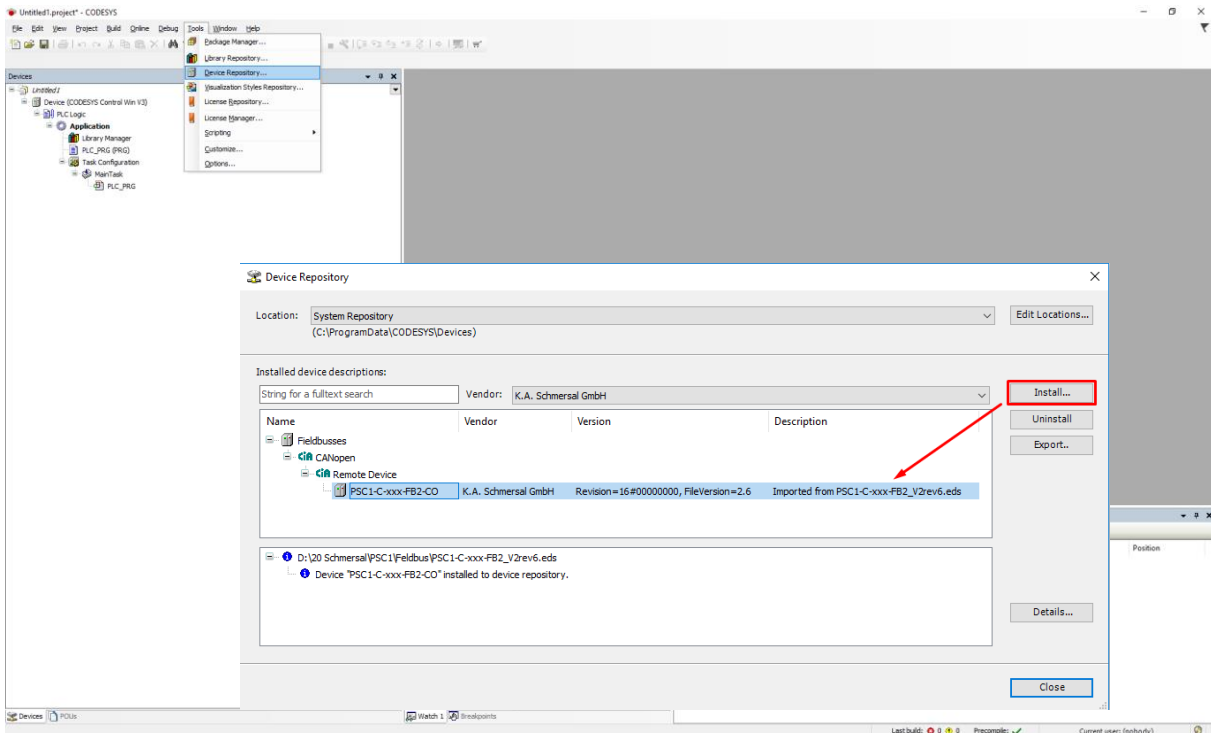

Via the device repository first install .eds file and thereby making it available for projects.

15.2 Creating a new project

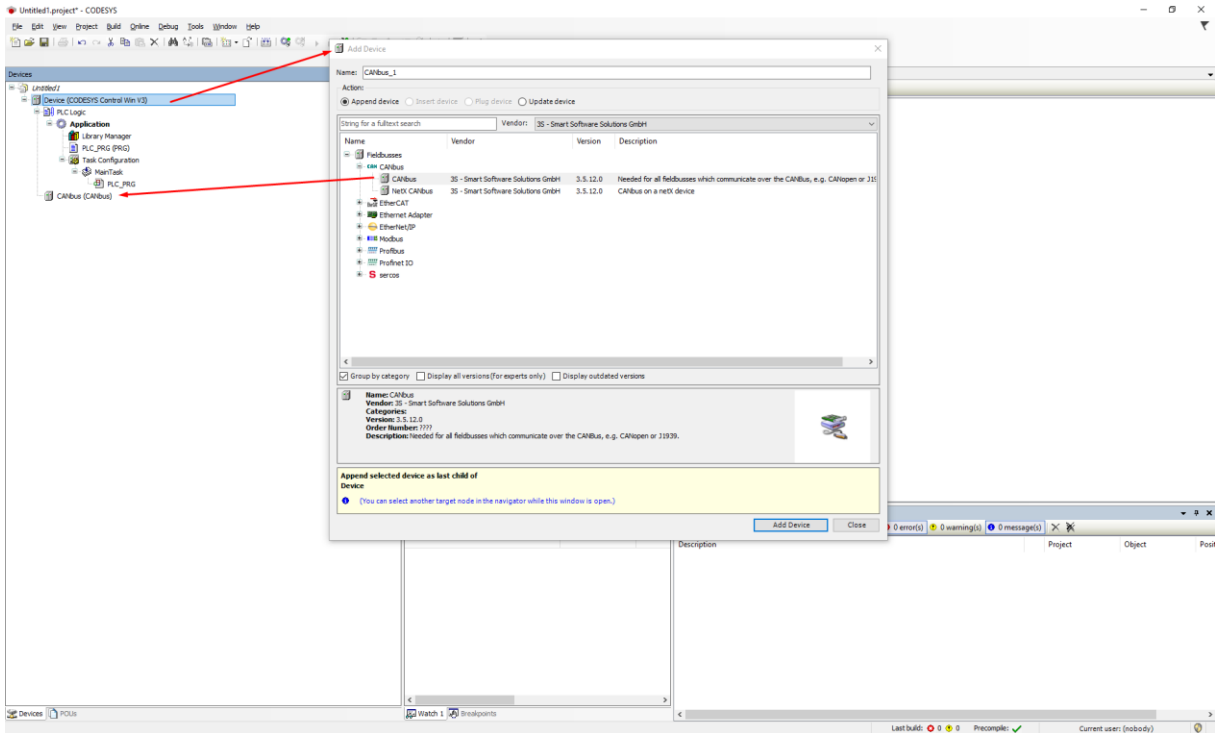

In order to integrate a CANopen Device into the hardware configuration, a CANbus master...

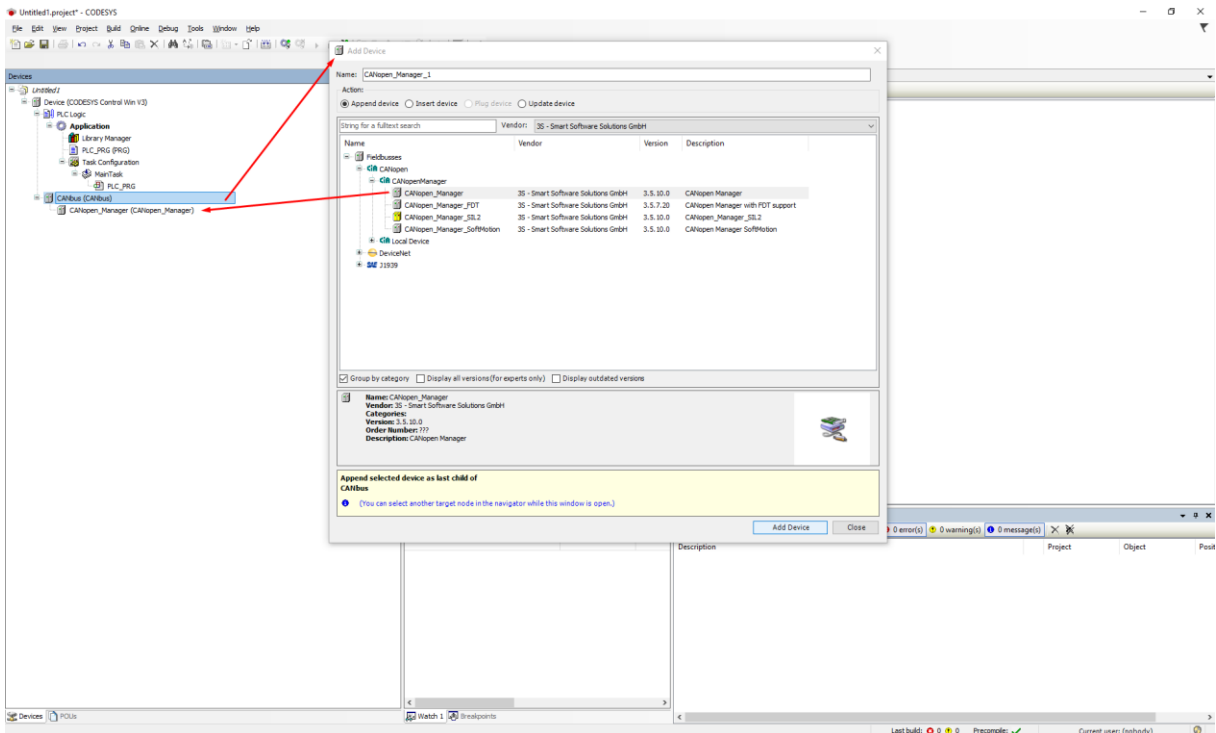

... and a CANopen manager are required.

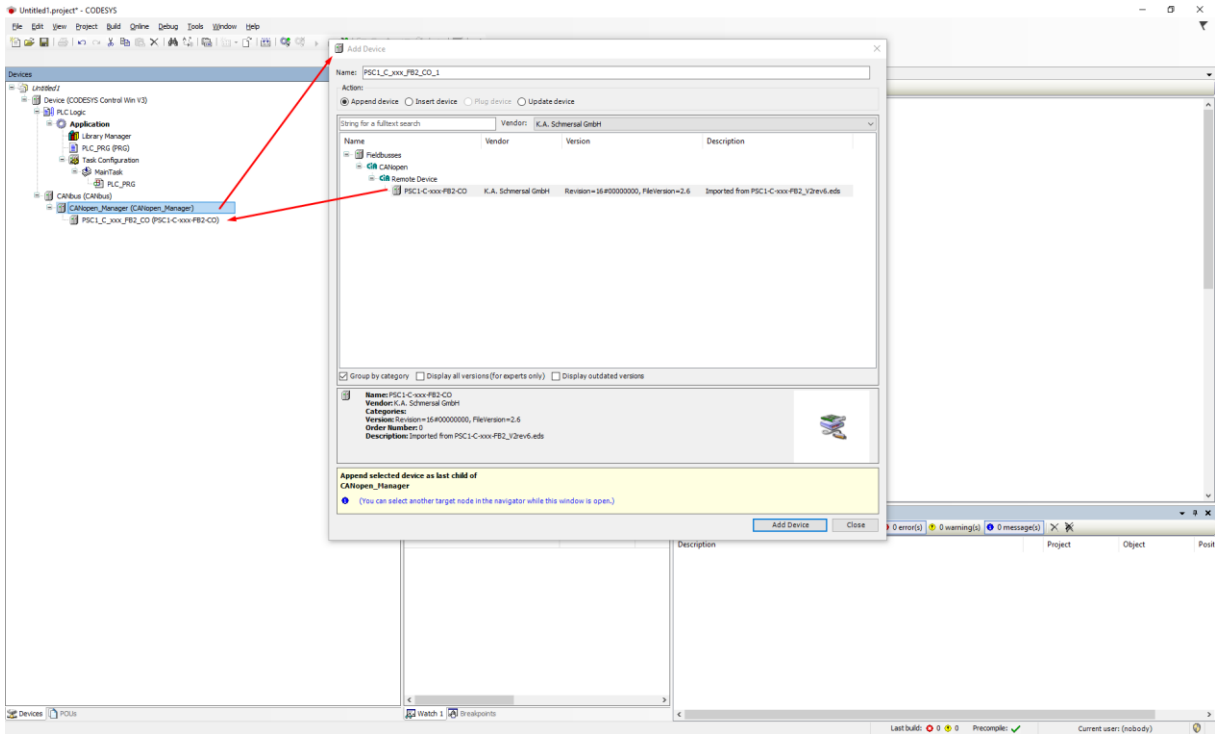

Finally, the PSC1 is added.

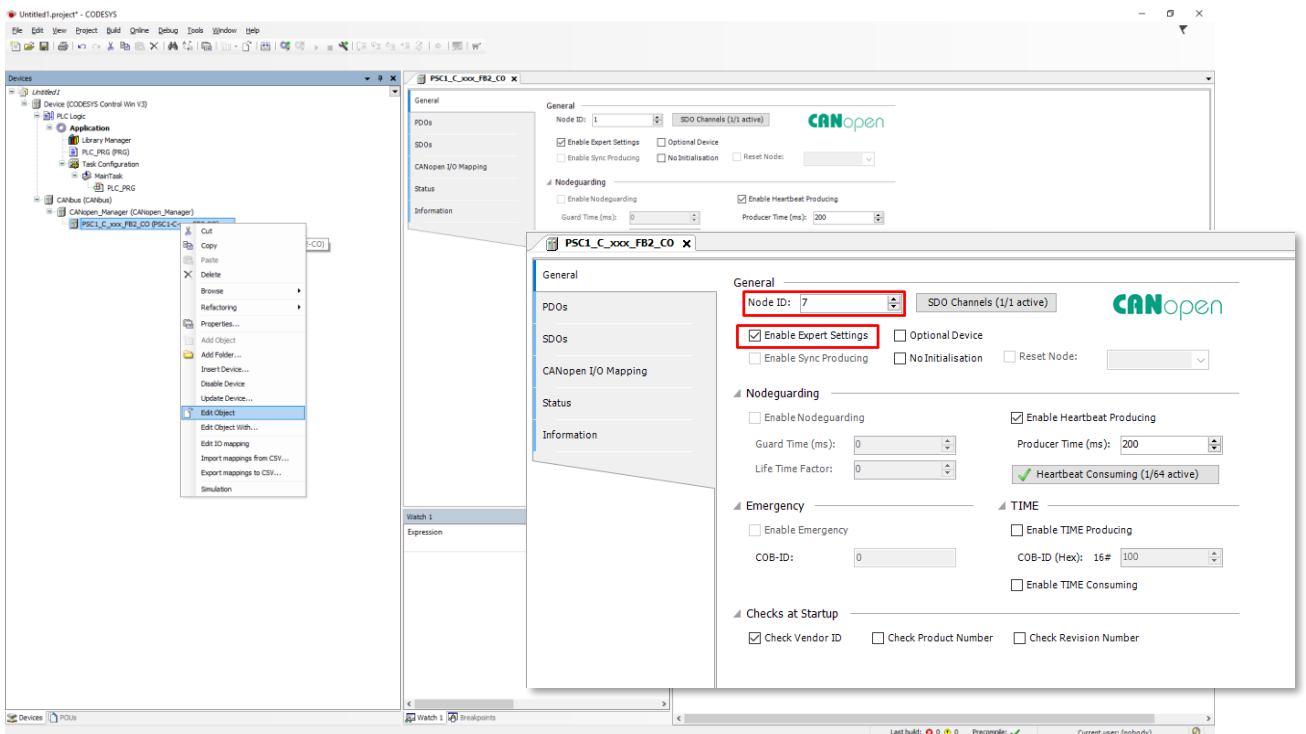

Via 'Edit object' now the participant address and the process data objects (PDO) can be modified. The address is set according to the setting of the PSC1 (see Chapter 5.4).

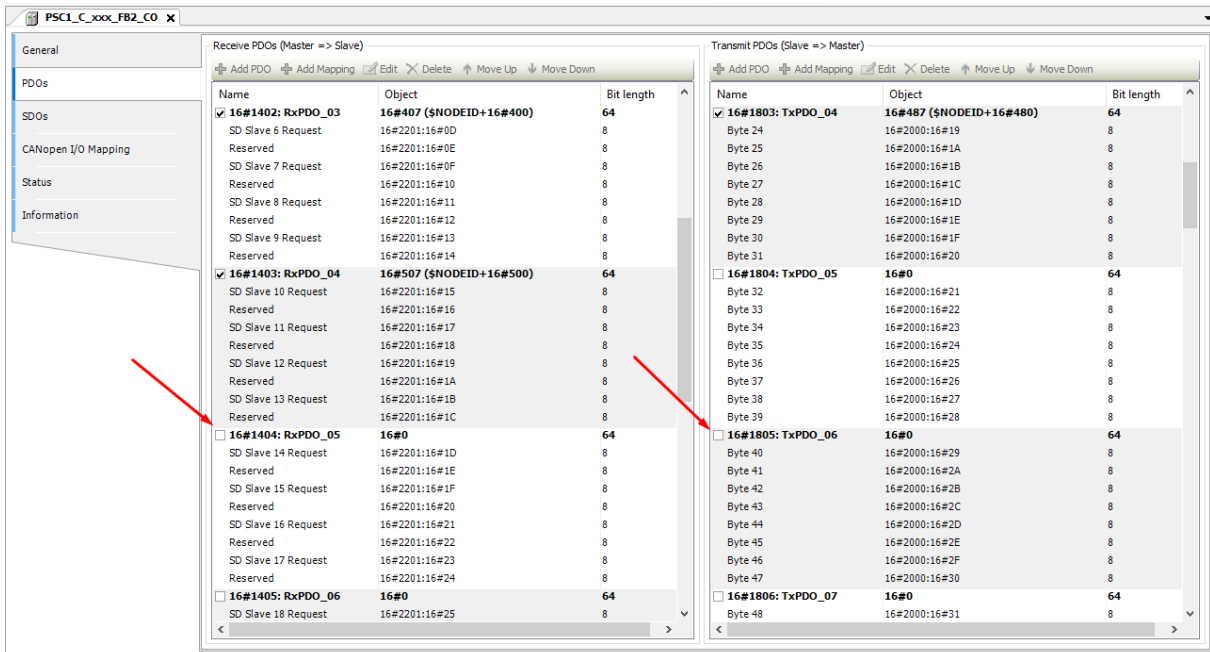

By default, all available PDOs are displayed but according to the CANopen specification only the first 4 are activated for send or receive. Thus, the following data are available:

RxPDO (Master => Slave)

- 4 Byte functional inputs
- SD-Bus: Master and the slaves 1-13

TxPDO (Slave => Master)

- 32 Byte functional Outputs
- **Note:** No SD-Bus data is transferred in this setting.

If further PDOs are required, they must be activated manually. After the activation of the listed PDOs, the COB-IDs for the new PDOs must often also be entered, but in most cases this is done automatically or by confirming the proposed COB-IDs.

The screenshot displays the CANopen Manager interface for a project named 'PSC1_C_XXX_FB2_CO'. The main window shows a table of variable mappings:

Variable	Mapping	Channel	Address	Type	Unit	Description
		Byte 0	%QB0	USINT		
		Byte 1	%QB1	USINT		
		Byte 2	%QB2	USINT		
		Byte 3	%QB3	USINT		
		SD Master Request	%QB4	USINT		
		SD Master Address	%QB5	USINT		
		SD Slave 1 Request	%QB6	USINT		
		Reserved	%QB7	USINT		
		SD Slave 2 Request	%QB8	USINT		
		Reserved	%QB9	USINT		
		SD Slave 3 Request	%QB10	USINT		
		Reserved	%QB11	USINT		
		SD Slave 4 Request	%QB12	USINT		
		Reserved	%QB13	USINT		
		SD Slave 5 Request	%QB14	USINT		
		Reserved	%QB15	USINT		
		SD Slave 6 Request	%QB16	USINT		
		Reserved	%QB17	USINT		
		SD Slave 7 Request	%QB18	USINT		
		Reserved	%QB19	USINT		
		SD Slave 8 Request	%QB20	USINT		
		Reserved	%QB21	USINT		
		SD Slave 9 Request	%QB22	USINT		

The 'Messages' window shows a warning: 'Multiple assignment of COB-ID 16#0: PSC1_C...'. A context menu is open over this message with the option 'Go To Source Position' selected.

The 'Node ID and COBID Conflicts' dialog box is displayed, containing the following table:

Device name	Node ID	Index	Formula	Conflicted COB-ID	Automatic suggestion
PSC1_C_XXX_FB2_CO	7	16#1404	16#80000000	16#00000000	16#00000681
PSC1_C_XXX_FB2_CO	7	16#1405	16#80000000	16#00000000	16#00000682
PSC1_C_XXX_FB2_CO	7	16#1406	16#80000000	16#00000000	16#00000683
PSC1_C_XXX_FB2_CO	7	16#1407	16#80000000	16#00000000	16#00000684
PSC1_C_XXX_FB2_CO	7	16#1408	16#80000000	16#00000000	16#00000685
PSC1_C_XXX_FB2_CO	7	16#1804	16#80000000	16#00000000	16#00000686
PSC1_C_XXX_FB2_CO	7	16#1805	16#80000000	16#00000000	16#00000687
PSC1_C_XXX_FB2_CO	7	16#1806	16#80000000	16#00000000	16#00000688
PSC1_C_XXX_FB2_CO	7	16#1807	16#80000000	16#00000000	16#00000689
PSC1_C_XXX_FB2_CO	7	16#1808	16#80000000	16#00000000	16#0000068A
PSC1_C_XXX_FB2_CO	7	16#1809	16#80000000	16#00000000	16#0000068B

The dialog box includes a note: 'Note: It is recommended to fix all Node ID errors before solving COBID conflicts.' and a button labeled 'Use suggested COBIDs'.