



EN Operating instructions.pages 1 to 7
Original

Content

1 About this document

1.1 Function 1

1.2 Target group: authorised qualified personnel. 1

1.3 Explanation of the symbols used 1

1.4 Appropriate use 1

1.5 General safety instructions 1

1.6 Warning about misuse 1

1.7 Exclusion of liability 2

2 Product description

2.1 Ordering code 2

2.2 Special versions. 2

2.3 Purpose 2

2.4 Technical data 2

2.5 Safety classification 3

2.6 Derating curve 3

3 Mounting

3.1 General mounting instructions 3

3.2 Dimensions 3

4 Electrical connection

4.1 General information for electrical connection. 3

5 Operating principle and settings

5.1 LED functions. 3

5.2 Description of the terminals 4

5.3 Notes 4

5.4 Setting report SRB211AN 5

6 Set-up and maintenance

6.1 Functional testing. 5

6.2 Maintenance 5

7 Disassembly and disposal

7.1 Disassembly. 5

7.2 Disposal 5

8 Appendix

8.1 Wiring examples 5

8.2 Start configuration 5

8.3 Sensor configuration 6

8.4 Actuator configuration 6

9 EU Declaration of conformity

1. About this document

1.1 Function

This operating instructions manual provides all the information you need for the mounting, set-up and commissioning to ensure the safe operation and disassembly of the safety relay module. The operating instructions must be available in a legible condition and a complete version in the vicinity of the device.

1.2 Target group: authorised qualified personnel

All operations described in this operating instructions manual must be carried out by trained specialist personnel, authorised by the plant operator only.

Please make sure that you have read and understood these operating instructions and that you know all applicable legislations regarding occupational safety and accident prevention prior to installation and putting the component into operation.

The machine builder must carefully select the harmonised standards to be complied with as well as other technical specifications for the selection, mounting and integration of the components.

1.3 Explanation of the symbols used



Information, hint, note:

This symbol is used for identifying useful additional information.



Caution: Failure to comply with this warning notice could lead to failures or malfunctions.

Warning: Failure to comply with this warning notice could lead to physical injury and/or damage to the machine.

1.4 Appropriate use

The Schmersal range of products is not intended for private consumers.

The products described in these operating instructions are developed to execute safety-related functions as part of an entire plant or machine. It is the responsibility of the manufacturer of a machine or plant to ensure the correct functionality of the entire machine or plant.

The safety relay module must be exclusively used in accordance with the versions listed below or for the applications authorised by the manufacturer. Detailed information regarding the range of applications can be found in the chapter "Product description".

1.5 General safety instructions

The user must observe the safety instructions in this operating instructions manual, the country specific installation standards as well as all prevailing safety regulations and accident prevention rules.



Further technical information can be found in the Schmersal catalogues or in the online catalogue on the Internet: products.schmersal.com.

The information contained in this operating instructions manual is provided without liability and is subject to technical modifications.

There are no residual risks, provided that the safety instructions as well as the instructions regarding mounting, commissioning, operation and maintenance are observed.

1.6 Warning about misuse



In case of inadequate or improper use or manipulations of the safety relay module, personal hazards or damages to machinery or plant components cannot be excluded.

1.7 Exclusion of liability

We shall accept no liability for damages and malfunctions resulting from defective mounting or failure to comply with this operating instructions manual. The manufacturer shall accept no liability for damages resulting from the use of unauthorised spare parts or accessories.

For safety reasons, invasive work on the device as well as arbitrary repairs, conversions and modifications to the device are strictly forbidden; the manufacturer shall accept no liability for damages resulting from such invasive work, arbitrary repairs, conversions and/or modifications to the device.

The safety relay module must only be used when the enclosure is closed, i.e. with the front cover fitted.

2. Product description

2.1 Ordering code

This operating instructions manual applies to the following types:

SRB211AN^① V.2

No.	Option	Description
①		Plug-in screw terminals 0.25...2.5 mm ²
	/CC	Plug-in cage clamps 0.25 ... 1.5 mm ²
	/PC	Screw terminals 0.25...2.5 mm ²



Only if the information described in this operating instructions manual are realised correctly, the safety function and therefore the compliance with the Machinery Directive is maintained.

2.2 Special versions

For special versions, which are not listed in the order code below 2.1, these specifications apply accordingly, provided that they correspond to the standard version.

2.3 Purpose

The safety relay modules for integration in safety circuits are designed for fitting in control cabinets. They are used for the safe evaluation of the signals of positive break position switches for safety functions or magnetic safety sensors on sliding, hinged and removable safety guards as well as emergency stop control devices.

The safety function is defined as the opening of the enabling circuits 13-14 and 23-24 and the delayed opening of the enabling circuits 37-38 when the input S21-S22 is opened and/or when the input S13-S14 is closed. The safety-relevant current paths with the outputs contacts 13-14 and 23-24 meet the following requirements under observation of a PFH value assessment (also refer to chapter 2.5 "Safety classification"):

- Category 4 – PL e to DIN EN ISO 13849-1
- Corresponds to SIL 3 to IEC 61508

The safety-relevant current path with the outputs contact 37-38 meet the following requirements under observation of a B_{10D} value assessment (also refer to chapter 2.5 "Safety classification"):

- Category 3 - PL d to DIN EN ISO 13849-1
- Corresponds to SIL 2 to IEC 61508

To determine the Performance Level (PL) to DIN EN ISO 13849-1 of the entire safety function (e.g. sensor, logic, actuator), an assessment of all relevant components is required.



The entire concept of the control system, in which the safety component is integrated, must be validated to the relevant standards.

2.4 Technical data

General data:

Standards:	EN 60204-1, DIN EN 60947-5-1, GS-ET-20, DIN EN ISO 13849-1, IEC 61508
Climate resistance:	EN 60068-2-78
Mounting:	snaps onto standard rail to EN 60715
Terminal designations:	EN 60947-1
Material of the housings:	Plastic, glass-fibre reinforced thermoplastic, ventilated
Material of the contacts:	AgSnO, AgNi, self-cleaning, positive drive
Weight:	230 g
Start conditions:	Automatic or start button (monitored)
Feedback circuit available:	yes
Pull-in delay for automatic start:	typ. 120 ms, max. 130 ms
Pull-in delay with reset button:	typ. 10 ms, max. 15 ms
Drop-out delay in case of emergency stop:	typ. 15 ms, max. 20 ms
Drop-out delay on "supply failure":	≤ 55 ms
Bridging in case of voltage drops:	≤ 40 ms

Mechanical data:

Connection type:	refer to 2.1 Ordering code
Cable section:	refer to 2.1 Ordering code
Connecting cable:	rigid or flexible
Tightening torque for the terminals:	0.6 Nm
With removable terminals:	see 2.1 Ordering code
Mechanical life:	10 million operations
Resistance to shock:	10 g / 11 ms
Resistance to vibration in accordance with EN 60068-2-6:	10 to 150 Hz, Amplitude 0.35 mm
Ambient temperature:	-25 °C ... +60 °C
Storage and transport temperature:	-40 °C ... +85 °C
Degree of protection:	Enclosure: IP40 Terminals: IP20 Clearance: IP54
Air clearances and creepage distances to EN 60664-1:	4 kV/2 (basic insulation)
EMC rating:	to EMC Directive

Electrical data:

Contact resistance in new state:	max. 100 mΩ
Power consumption:	2.4 W / 5.9 VA, plus signalling output
Rated operating voltage U _e :	24 VDC: -15% / +20%, residual ripple max. 10% 24 VAC: -15% / +10%
Frequency range:	50 / 60 Hz
Fuse rating for the operating voltage:	Internal electronic trip, tripping current F1: > 750 mA; tripping current F2: > 75 mA; Reset after disconnection of supply voltage; tripping current F3: > 140 mA
Current and voltage at the control circuits:	
- S13, S14, S21, S22:	24 VDC, 10 mA
- X1, X2:	24 VDC, start impulse 25 mA / 25 ms
- X1, X3:	24 VDC, start impulse 950 mA / 10 ms

Monitored inputs:

Cross-wire detection:	yes
Wire breakage detection:	yes
Earth connection detection:	yes
Number of NO contacts:	1
Number of NC contacts:	1
Cable length:	1,500 m with 1.5 mm ² 2,500 m with 2.5 mm ²
Conduction resistance:	max. 40 Ω

Outputs:

Number of safety contacts:	3
Number of auxiliary contacts:	0
Number of signalling outputs:	1
Switching capacity of safety contacts (note derating curve item 2.6):	
- 13-14, 23-24 (STOP 0):	max. 250 V, 8 A ohmic (inductive with suitable protection circuit); min. 5 V / 5 mA
- 37-38 (STOP 1):	max. 250 V, 6 A ohmic (inductive with suitable protection circuit); min. 10 V / 10 mA
Switching capacity of the signalling outputs:	Y1: 24 VDC / 100 mA

Fuse rating of the safety contacts: external ($I_k = 1000\text{ A}$)
to EN 60947-5-1

- 13-14, 23-24 (STOP 0): Safety fuse 10 A quick blow, 8 A slow blow
- 37-38 (STOP 1): Safety fuse 8 A quick blow, 6.3 A slow blow

Fuse rating of the signalling output: Y1: 100 mA (internal electronic trip F4)

Utilisation category to DIN EN 60947-5-1: AC-15 / DC-13

The data specified in this manual are applicable when the component is operated with rated operating voltage $U_e \pm 0\%$.

2.5 Safety classification

Standards:	DIN EN ISO 13849-1, IEC 61508
PL:	STOP 0: up to e, STOP 1: up to d
Category:	STOP 0: up to 4, STOP 1: up to 3
PFH value:	STOP 0: $\leq 2.0 \times 10^{-8}/h$, STOP 1: $\leq 2.0 \times 10^{-7}/h$
DC:	STOP 0: 99% (high), STOP 1: > 60% (low)
CCF:	> 65 points
SIL:	STOP 0: up to 3, STOP 1: up to 2
Mission time:	20 years

The PFH values of $2.0 \times 10^{-8}/h$ and $2.0 \times 10^{-7}/h$ applies to the combinations of contact load (current through enabling contacts) and number of switching cycles (n_{oply}) mentioned in the table below. At 365 operating days per year and a 24-hours operation, this results in the below-mentioned switching cycle times (t_{cycle}) for the relay contacts. Diverging applications upon request.

Contact load	n_{oply}	t_{cycle}
20 %	525,600	1.0 min
40 %	210,240	2.5 min
60 %	75,087	7.0 min
80 %	30,918	17.0 min
100 %	12,223	43.0 min

2.6 Derating curve

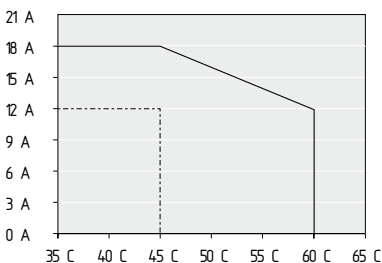

Fig. 1:
vertical = residual current;
horizontal = ambient temperature;
continuous line: operating voltage/thermal test current DC;
dashed line: operating voltage/thermal test current AC.
Mounting distance to other safety-relay modules as of a residual current > 6 A: at least 10 mm

Derating curve depending on the rated operating voltage U_e of the SRB safety relay module.

3. Mounting

3.1 General mounting instructions

Mounting: snaps onto standard rails to EN 60715.

Snap the bottom of the enclosure slightly tilted forwards in the standard rail and push up until it latches in position.

3.2 Dimensions

Device dimensions (H/W/D):

SRB211AN/PC V.2:	100 × 22.5 × 121 mm
SRB211AN V.2:	120 × 22.5 × 121 mm
SRB211AN/CC V.2:	130 × 22.5 × 121 mm

4. Electrical connection

4.1 General information for electrical connection



As far as the electrical safety is concerned, the protection against unintentional contact of the connected and therefore electrically interconnected apparatus and the insulation of the feed cables must be designed for the highest voltage, which can occur in the device.



The electrical connection may only be carried out by authorised personnel in a de-energised condition.

Settle length x of the conductor:

- SRB211AN V.2:	7 mm
- SRB211AN/CC V.2:	8 mm
- SRB211AN/PC V.2:	8 mm



To avoid EMC disturbances, the physical ambient and operational conditions at the place where the product is installed, must meet the provisions laid down in the paragraph "Electromagnetic Compatibility (EMC)" of EN 60204-1.

Wiring examples: see appendix

5. Operating principle and settings

5.1 LED functions

- K1: Status channel 1
- K2: Status channel 2
- K3: Status delayed enabling circuit channel 1
- K4: Status delayed enabling circuit channel 2
- U_B : Status operating voltage (LED is on, when the operating voltage on the terminals A1-A2 is ON)
- U_i : Status internal operating voltage (LED is on, when the operating voltage on the terminals A1-A2 is ON and the fuse has not been triggered).

5.2 Description of the terminals

(see Fig. 2)

Voltages:	A1	+24 VDC/24 VAC
	A2	0 VDC/24 VAC
Inputs:	S13-S14	Input channel 1
	S21-S22	Input channel 2
Outputs:	13-14	First safety enabling circuit (STOP 0)
	23-24	Second safety enabling circuit (STOP 0)
	37-38	Third safety enabling circuit (STOP 1)
Start:	X1-X2	Feedback circuit and external reset (monitored)
	X1-X3	Automatic start
	Y1	Signalling output

Opening the front cover (see Fig. 3)

- To open the front cover, insert a slotted screwdriver in the top and bottom cover notch and gently lift it.
- When the front cover is open, the electrostatic discharge requirements must be respected and observed.
- After setting, the front cover must be fitted back in position.
- The set drop-out delay must be entered on the front cover.



Only touch the components after electrical discharge!

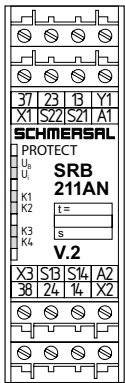

Fig. 2

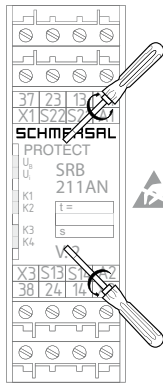

Fig. 3

Time setting (see Fig. 4 and 5)



DIP switch settings:

- The DIP switches are located underneath the front cover of the safety-relay module (see Fig. 4 and 5).
- Both DIP switches SW 1 (channel 1) and SW 2 (channel 2) must be set identically.
- The DIP switches can be set when the operating voltage is on; however, in order for the setting to be saved in the SRB211AN, the voltage supply must be interrupted for approx. 3 seconds.
- The set drop-out delay must be checked and entered on the front cover and in the settings report.



New adjustable drop-out delays for version V.2, see Fig. 4. Tolerance $\pm 2\%$

DIP switch setting	Drop-out delay	DIP switch setting	Drop-out delay
	<0,1 s		5.0 s
	0.5 s		8.5 s
	1.0 s		10.0 s
	1.5 s		12.0 s
	2.0 s		15.0 s
	2.5 s		20.0 s
	3.0 s		25.0 s
	4.0 s		30.0 s

Fig. 4

AF1



AF2



Fig. 5

Resetting the hybrid fuse

- The hybrid fuse of the safety-relay module can be reset by switching the operating voltage off and back on.

5.3 Notes

Delayed enabling circuits (see Fig. 6)

- The drop-out delay of the safety enabling circuits 37-38 can be set within the range of 0...30 seconds by means of DIP switches. The DIP switches are located underneath the front cover of the safety-relay module.
- The safety enabling circuit 37-38 meets STOP category 1 to EN 60204-1.
- The drop-out delays of the safety enabling circuits STOP 1 can be reduced in case of a failure.

Signalling output Y1 (see Fig. 7)

- The safety relays K1, K2 are signalled through signalling output Y1.

K1	K2	Y1
On	On	low (0 V)
On	Off	low (0 V)
Off	On	low (0 V)
Off	Off	high (+ 24 V)

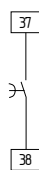

Fig. 6

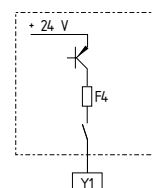

Fig. 7

5.4 Setting report SRB211AN

This report regarding the setting of the device must be completed accordingly by the customer and enclosed in the technical manual of the machine.

The setting report must be available whenever a safety check is performed.

Company: _____

The safety-relay module is used in the following machine:

Machine n° _____ Machine type _____ SRB module no. _____

Set drop-out delay: _____

Set on (date) _____ Signature of the responsible person _____

6. Set-up and maintenance

6.1 Functional testing

The safety function of the safety relay module must be tested. The following conditions must be previously checked and met:

1. Correct fixing
2. Check the integrity of the cable entry and connections
3. Check the safety relay module's enclosure for damage.
4. Check the electrical function of the connected sensors and their influence on the safety relay module and the downstream actuators

6.2 Maintenance

A regular visual inspection and functional test, including the following steps, is recommended:

1. Check the correct fixing of the safety relay module
2. Check the cable for damages
3. Check electrical function
4. Check drop-out delay



If a manual functional check is necessary to detect a possible accumulation of faults, then this must take place during the intervals noted as follows:

- at least every month for PL e with category 3 or category 4 (according to DIN EN ISO 13849-1);
- at least every 12 months for PL d with category 3 (according to DIN EN ISO 13849-1).

Damaged or defective components must be replaced.

7. Disassembly and disposal

7.1 Disassembly

The safety relay module must be disassembled in a de-energised condition only.

Push up the bottom of the enclosure and hang out slightly tilted forwards.

7.2 Disposal

The safety relay module must be disposed of in an appropriate manner in accordance with the national prescriptions and legislations.

8. Appendix

8.1 Wiring examples

Dual-channel control, shown for a guard door monitor; with two contacts A and B, where at least one is a positive break contact; with external reset button (R) (see Fig. 8)

- Relay outputs: Suitable for 2-channel control, for increase in capacity or number of contacts by means of contactors or relays with positive-guided contacts.
- The control system recognises wire-breakage, earth faults and cross-wire shorts in the monitoring circuit.

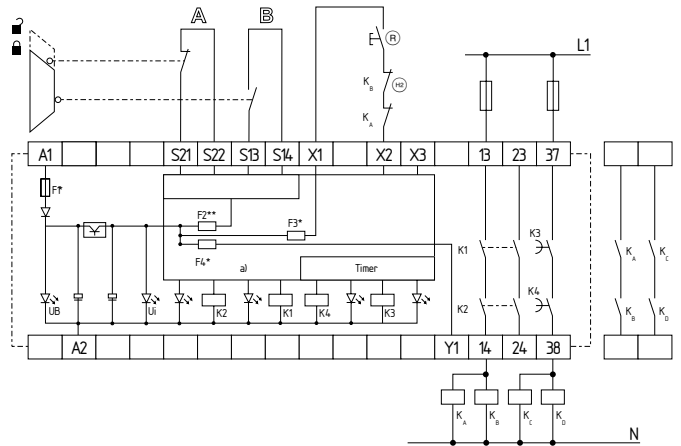

Fig. 8
a) Logic
* Electronic fuse
** Hybrid fuse
Ⓜ Feedback circuit

8.2 Start configuration

External reset button (with edge detection) (see Fig. 9)

- The external reset button is integrated as shown.
- The safety-relay module is activated by the reset (after release) of the reset button (= detection of the trailing edge). Faults in the reset button, e.g. welded contacts or manipulations which could lead to an inadvertent restart, are detected in this configuration and will result in an inhibition of the operation.

Automatic start (see Fig. 10)

- The automatic start is programmed by connecting the feedback circuit to the terminals. If the feedback circuit is not required, establish a bridge.
- **Caution:** Not admitted without additional measure due to the risk of gaining access by stepping behind!
- **Caution:** within the meaning of EN 60204-1, paragraph 9.2.3.4.2, the operating mode "automatic start" is only restrictedly admissible. In particular, any inadvertent restart of the machine must be prevented by other suitable measures.

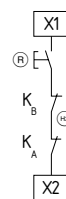

Fig. 9

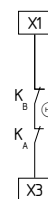

Fig. 10

8.3 Sensor configuration

Dual-channel emergency stop circuit with command devices to EN ISO 13850 and EN 60947-5-5 (Fig. 11)

- Wire breakage and earth leakage in the control circuits are detected.
- Cross-wire shorts between the control circuits are detected.
- Category 4 – PL e to DIN EN ISO 13849-1 possible.

Dual-channel guard door monitoring circuit with interlocking device to EN ISO 14119 (Fig. 12)

- With at least one positive-break position switch
- Wire breakage and earth leakage in the control circuits are detected.
- Cross-wire shorts between the control circuits are detected.
- Category 4 – PL e to DIN EN ISO 13849-1 possible.

Dual-channel control of magnetic safety switches to EN 60947-5-3 (see Fig. 13)

- Wire breakage and earth leakage in the control circuits are detected.
- Cross-wire shorts between the monitoring circuits are detected.
- Category 4 – PL e to DIN EN ISO 13849-1 possible.

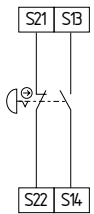

Fig. 11

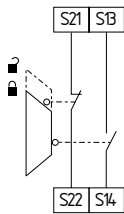

Fig. 12

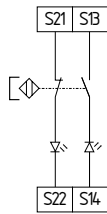

Fig. 13

! The connection of magnetic safety switches to the safety relay modules is only admitted when the requirements of the standard EN 60947-5-3 are observed. As the technical data are regarded, the following minimum requirements must be met:

- switching capacity: min. 240 mW
- switching voltage: min. 24 VDC
- switching current: min. 10 mA

! For example, the following safety sensors meet the requirements:

- BNS 33-11Z, BNS 33-11Z-2063, BNS 33-11ZG-2237
- BNS 250-11Z, BNS 250-11ZG
- BNS 120-11Z
- BNS 180-11Z
- BNS 303-11Z, BNS 303-11ZG
- BNS 260-11Z, BNS 260-11ZG
- BNS 36

! Caution! When sensors with LEDs are wired in the control circuit (protective circuit), the following rated operating voltage must be observed and respected:

- 24 VDC with a max. tolerance of –5%/+20 %
- 24 VAC with a max. tolerance of –5%/+10 %

Otherwise availability problems could occur, especially in series-wired sensors, where a voltage drop in the control circuit is triggered by LEDs for instance

8.4 Actuator configuration

Single-channel control with feedback circuit (Fig. 14)

- Suitable for increase in capacity or number of contacts by means of contactors or relays with positive-guided contacts.
- HE = feedback circuit:
If the feedback circuit is not required, establish a bridge.

Dual-channel control with feedback circuit (see Fig. 15)

- Suitable for increase in capacity or number of contacts by means of contactors or relays with positive-guided contacts.
- HE = feedback circuit:
If the feedback circuit is not required, establish a bridge.

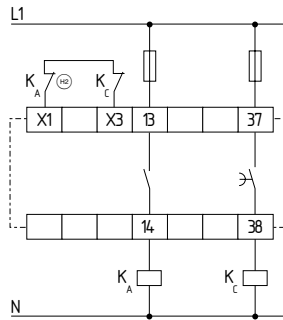

Fig. 14

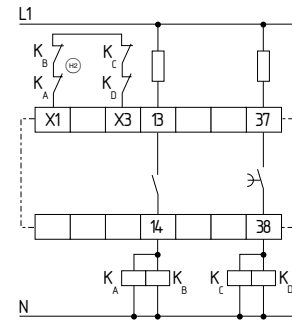

Fig. 15

Differential control with feedback circuit (see Fig. 16)

- Suitable for increase in capacity or number of contacts by means of contactors or relays with positive-guided contacts.
- HE = feedback circuit:
If the feedback circuit is not required, establish a bridge.

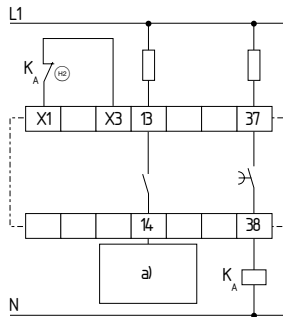

Fig. 16 a) Enabling signal controller

9. EU Declaration of conformity

EU Declaration of conformity



Original
K.A. Schmersal GmbH & Co. KG
Möddinghofe 30
42279 Wuppertal
Germany
Internet: www.schmersal.com

We hereby certify that the hereafter described components both in their basic design and construction conform to the applicable European Directives.

Name of the component:
SRB211AN V.2
SRB211AN/CC V.2
SRB211AN/PC V.2

Description of the component:
Safety relay module for emergency stop circuits,
guard door monitoring and magnetic safety switches

Relevant Directives:
Machinery Directive 2006/42/EC
EMC-Directive 2014/30/EU
RoHS-Directive 2011/65/EU

Applied standards:
DIN EN 60947-5-1:2018
DIN EN ISO 13849-1:2023

Notified body for Type Examination:
DGUV Test
Prüf- und Zertifizierungsstelle
Elektrotechnik
Gustav-Heinemann-Ufer 130 5
0968 Köln
ID n°: 0340

EC-Type Examination Certificate:
ET 24017

**Person authorised for the compilation
of the technical documentation:**
Oliver Wacker
Möddinghofe 30
42279 Wuppertal

Place and date of issue:
Wuppertal, September 27, 2024

Authorised signature
Philip Schmersal
Managing Director

SRB211AN V2-F-EN



The currently valid declaration of conformity can be
downloaded from the internet at products.schmersal.com.

