



EN Operating instructions.pages 1 to 6
Original

Content

1 About this document

1.1 Function 1

1.2 Target group: authorised qualified personnel. 1

1.3 Explanation of the symbols used 1

1.4 Appropriate use 1

1.5 General safety instructions 1

1.6 Warning about misuse 2

1.7 Exclusion of liability 2

2 Product description

2.1 Ordering code 2

2.2 Special versions. 2

2.3 Destination and use 2

2.4 Technical data 2

2.5 Safety classification 2

3 Mounting

3.1 General mounting instructions 3

3.2 Dimensions 3

3.3 Axial misalignment. 3

3.4 Adjustment. 3

4 Electrical connection

4.1 General information for electrical connection. 4

4.2 Contact variants. 4

4.3 Connector plug. 4

5 Set-up and maintenance

5.1 Functional testing. 4

5.2 Maintenance 4

6 Disassembly and disposal

6.1 Disassembly. 4

6.2 Disposal. 4

7 EU Declaration of conformity

1. About this document

1.1 Function

This operating instructions manual provides all the information you need for the mounting, set-up and commissioning to ensure the safe operation and disassembly of the safety switchgear. The operating instructions must be available in a legible condition and a complete version in the vicinity of the device.

1.2 Target group: authorised qualified personnel

All operations described in this operating instructions manual must be carried out by trained specialist personnel, authorised by the plant operator only.

Please make sure that you have read and understood these operating instructions and that you know all applicable legislations regarding occupational safety and accident prevention prior to installation and putting the component into operation.

The machine builder must carefully select the harmonised standards to be complied with as well as other technical specifications for the selection, mounting and integration of the components.

1.3 Explanation of the symbols used



Information, hint, note:

This symbol is used for identifying useful additional information.



Caution: Failure to comply with this warning notice could lead to failures or malfunctions.

Warning: Failure to comply with this warning notice could lead to physical injury and/or damage to the machine.

1.4 Appropriate use

Products in Schmersal's range are not intended to be used by private end consumers.

The products described in these operating instructions are developed to execute safety-related functions as part of an entire plant or machine. It is the responsibility of the manufacturer of a machine or plant to ensure the correct functionality of the entire machine or plant.

The safety switchgear must be exclusively used in accordance with the versions listed below or for the applications authorised by the manufacturer. Detailed information regarding the range of applications can be found in the chapter "Product description".

1.5 General safety instructions

The user must observe the safety instructions in this operating instructions manual, the country-specific installation standards as well as all prevailing safety regulations and accident prevention rules.



Further technical information can be found in the Schmersal catalogues or in the online catalogue on the Internet: products.schmersal.com.

The information contained in this operating instructions manual is provided without liability and is subject to technical modifications.

There are no residual risks, provided that the safety instructions as well as the instructions regarding mounting, commissioning, operation and maintenance are observed.

1.6 Warning about misuse



In case of improper use or manipulation of the safety switchgear, personal hazards or damages to machinery or plant components cannot be excluded when safety switchgear is used. The relevant requirements of the standard EN ISO 14119 must be observed.

1.7 Exclusion of liability

We shall accept no liability for damages and malfunctions resulting from defective mounting or failure to comply with this operating instructions manual. The manufacturer shall accept no liability for damages resulting from the use of unauthorised spare parts or accessories.

For safety reasons, invasive work on the device as well as arbitrary repairs, conversions and modifications to the device are strictly forbidden; the manufacturer shall accept no liability for damages resulting from such invasive work, arbitrary repairs, conversions and/or modifications to the device.

2. Product description

2.1 Ordering code

This operating instructions manual applies to the following types:

BNS 16-①Z-②-③

No.	Option	Description
①	11	1 NO contact / 1 NC contact (only for version with integrated connector)
	12	1 NO contact / 2 NC contact
②	Actuating plane	
	V	front side
	R	right-hand side
	L	left-hand side
	D	cover-side
	U	bottom
③	LR	left- and right-hand side
	ST1	Connector in the middle
	ST2	Connector at the right-hand side
	ST3	Connector at the left-hand side

2.2 Special versions

For special versions, which are not listed in the order code below 2.1, these specifications apply accordingly, provided that they correspond to the standard version.

2.3 Destination and use

The safety sensor BNS 16 is designed for application in safety circuits and is used for monitoring the position of movable safety guards to EN ISO 14119 and EN 60947-5-3. To actuate the safety sensors, only the BPS 16 actuators can be used, conventional magnets are not suitable.



The safety switchgears are classified according to EN ISO 14119 as type 4 switching devices.

To ensure a safe switch-off, the distance between the safety sensor and the actuator must be at least 18 mm (s_{ar}) or higher (opening width of the safety guard).

For the BNS 16-12ZLR, the safe condition is only obtained, when the left and the right actuator are located in front of the safety sensor.

The safety switches are used for applications, in which the hazardous situation is terminated without delay when the safety guard is opened. Only the entire system consisting of the safety sensor (BNS 16), the actuator (BPS 16) and the safety-monitoring module (SRB) meets the requirements of the standard EN 60947-5-3.



The user must evaluate and design the safety chain in accordance with the relevant standards and the required safety level.



The entire concept of the control system, in which the safety component is integrated, must be validated to the relevant standards.

2.4 Technical data

Standards:	EN 60947-5-3, BG-GS-ET-14
Enclosure:	glass-fibre reinforced thermoplastic, self-extinguishing
Protection class:	IP67
Connection:	-11Z: connector M12 x 1, 4-pole -12Z: connector M12 x 1, 8-pole
Cable section:	max. 2 x 1.5 mm ² (incl. conductor ferrules)
Operating principle:	magnetic
Actuator:	BPS 16, coded
Coding level according to EN ISO 14119:	low
Switching distances:	
- Assured switching distance s_{so} :	8 mm
- Assured switch-off distance s_{ar} :	18 mm
Switching voltage:	max. 60 VAC/DC
Switching current:	max. 400mA
Switching capacity:	max. 10 W
Required short-circuit current:	100 A
Ambient temperature:	-25 °C ... +70 °C
Storage and transport temperature:	-25 °C ... +70 °C
Switching frequency:	max. 5 Hz
Resistance to shock:	30 g / 11 ms
Resistance to vibration:	10 ... 55 Hz, amplitude 1 mm



For use in NFPA 79 Applications.

Adapters providing field wiring means are available from the manufacturer. Refer to manufacturers information.

2.5 Safety classification

Standards:	EN ISO 13849-1
Safety contacts:	
- NC / NO combination:	S21-S22 and S13-S14
Intended structure:	
- 2-channel usage:	usable to cat. 4 / PL e with suitable logic unit
B_{10D} NC contacts at 20 % contact load:	25.000.000
B_{10D} NO contacts at 20 % contact load:	25.000.000
Service life:	20 years

$$MTTF_D = \frac{B_{10D}}{0,1 \times n_{op}} \quad n_{op} = \frac{d_{op} \times h_{op} \times 3600 \text{ s/h}}{t_{cycle}}$$

(Determined values can vary depending on the application-specific parameters h_{op} , d_{op} and t_{cycle} as well as the load.)

If multiple safety components are wired in series, the Performance Level to EN ISO 13849-1 will be reduced due to the restricted error detection under certain circumstances.

3. Mounting

3.1 General mounting instructions



During fitting, the requirements of EN ISO 14119 must be observed.

- Install the actuator so that the marks of the safety sensor and the actuator(s) are completely opposite when the safety guard is closed. The marking of the BNS 16 simultaneously identifies the active face.
- Fitting is only authorised in a de-energised condition
- Do not use the sensor and the actuator as a mechanical backstop
- Any mounting position, provided that the active surfaces are opposite
- Ensure the safety sensor is mounted on a flat surfaces to avoid tensile stresses that could damage the sensor or lead to varying switching distances
- If possible, do not install the safety sensor and the actuator on ferromagnetic material.
- Do not install the safety sensor and the actuator in strong magnetic fields
- Do not subject the components to extreme vibrations
- Keep away from metal chips
- The mounting distance between two sensors should always be at least 50 mm.



The actuator must be permanently fitted to the safety guards and protected against displacement by suitable measures (tamperproof screws, gluing, drilling of the screw heads).

3.2 Dimensions

All measurements in mm.

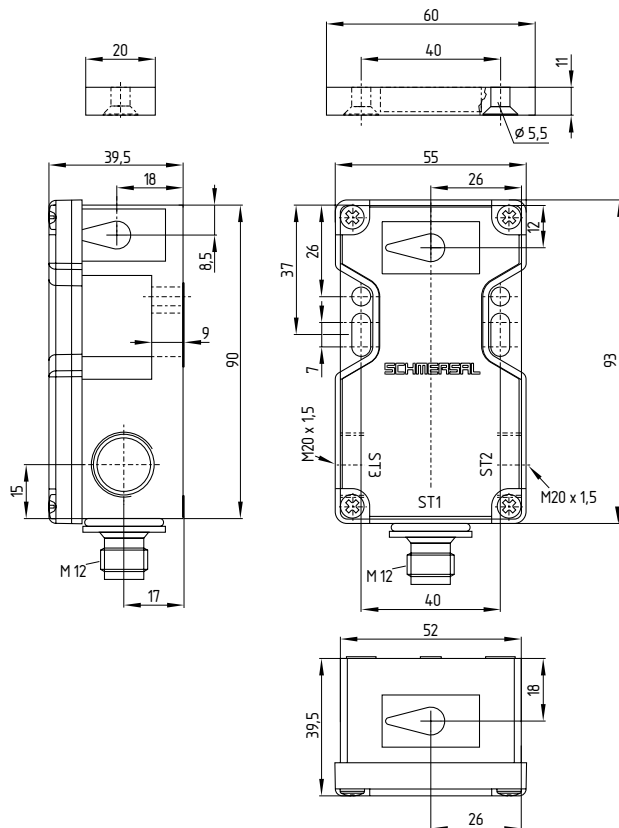

- ST1 Connector in the middle
 ST2 Connector at the right-hand side
 ST3 Connector at the left-hand side

Actuating planes BNS 16



BNS 16-12ZD
 BNS 16-12ZU
 BNS 16-12ZV
 BNS 16-12ZR
 BNS 16-12ZL

Actuating planes BNS 16 LR



BNS 16-12ZLR

3.3 Axial misalignment

A horizontal and vertical misalignment of the safety sensor and the actuator is tolerated. The possible misalignment depends on the distance of the active surfaces of the sensor and the actuator. The sensor remains active within the tolerance range.

The specified switching distances refer to opposedly mounted safety sensors and actuators.

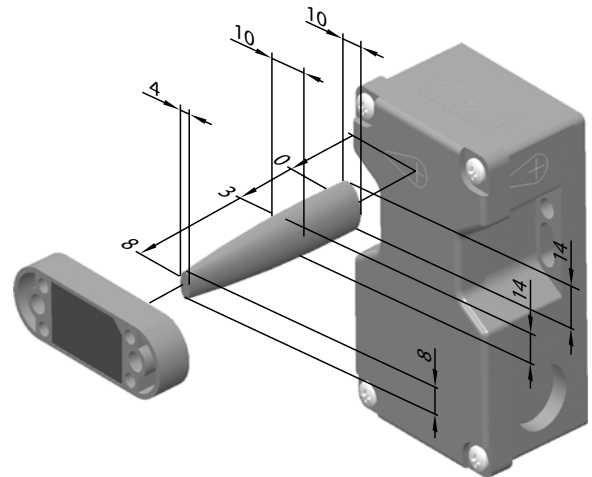

Assured switching distance: $s_{ao} = 8 \text{ mm}$

Assured switch-off distance: $s_{ar} = 18 \text{ mm}$

3.4 Adjustment



Recommended Adjustment

Align the safety sensor and actuator at a distance of $0.5 \times s_{ao}$.

The correct functionality must always be checked by means of the connected safety-monitoring module.

4. Electrical connection

4.1 General information for electrical connection



The electrical connection may only be carried out by authorised personnel in a de-energised condition.

The safety sensors must be wired in accordance with the specified pin configurations.

4.2 Contact variants

The contact position shows the actuated sensor function when the safety guard is closed.

Safety contacts: S21-S22 and S13-S14
 Signalling contact: S31-S32

BNS 16-11Z.-ST.

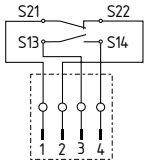

BNS 16-11Z.-ST.-2505-1

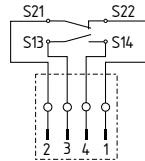

BNS 16-12Z.-ST.

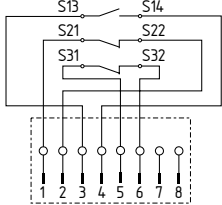

In combination with a safety-monitoring module, the wires of the safety sensor must be wired in the following way:

NO contact: S13-S14 at the "NO input" of the safety-monitoring module
 NC contact: S21-S22 at the "NC input" of the safety-monitoring module
 NO contact: only for BNS 16-12Z.-ST.: S31-S32 can be used for signalling purposes.

In this way, the coding of the safety sensor is ensured. Inductive loads (e.g. contactors, relays, etc.) are to be suppressed by means of a suitable circuit.



Information for the selection of suitable safety-monitoring modules can be found in the Schmersal catalogues or in the online catalogue on the Internet: products.schmersal.com.

Connecting multiple BNS 16 safety sensors to one SRB safety-monitoring module is technically possible. To connect multiple safety sensors (check if authorised!), their NO contacts are wired in parallel and their NC contacts in series. The Protect-IE-11 input expander module can be used to connect up to 4 safety sensors as NC/NO version.

4.3 Connector plug integrated connector

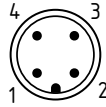

M12, 4-pole

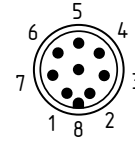

M12, 8-pole

Accessories: connecting cable with M 12 coupling, 4 pole, 5 m
 (Ordering code: 103009364)

M12, 4-pole

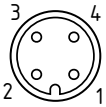

1	BN
2	WH
3	BU
4	BK

Accessories: connecting cable with M 12 coupling, 8 pole, 5 m
 (Ordering code: 103007358)

M12, 8-pole

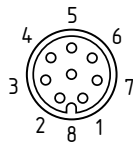

1	WH
2	BN
3	GN
4	YE
5	GY
6	PK
7	-
8	-

5. Set-up and maintenance

5.1 Functional testing

The safety function of the safety components must be tested. The following conditions must be previously checked and met:

1. Fitting of the sensor and the actuator
2. Fitting and integrity of the power cable
3. The system is free of dirt and soiling (in particular metal chips)

5.2 Maintenance

In the case of correct installation and adequate use, the safety sensor features maintenance-free functionality.

A regular visual inspection and functional test, including the following steps, is recommended:

- Check the fitting of the sensor and the actuator
- Remove possible metal chips
- Check the cable for damage.



Adequate measures must be taken to ensure protection against tampering either to prevent tampering of the safety guard, for instance by means of replacement actuators.

Damaged or defective components must be replaced.

6. Disassembly and disposal

6.1 Disassembly

The safety switchgear must be disassembled in a de-energised condition only.

6.2 Disposal

The safety switchgear must be disposed of in an appropriate manner in accordance with the national prescriptions and legislations.

7. EU Declaration of conformity

EU Declaration of conformity



Original
K.A. Schmersal GmbH & Co. KG
Möddinghofe 30
42279 Wuppertal
Germany
Internet: www.schmersal.com

We hereby certify that the hereafter described components both in their basic design and construction conform to the applicable European Directives.

Name of the component: BNS 16

Type: See ordering code

Description of the component: Coded safety-sensor with magnetic operating principle in combination with the SRB(-E) / PROTECT-SELECT / PSC1 safety-monitoring modules from Schmersal or an equivalent safety-oriented control system fulfilling the requirements of the EN 60947-5-3.

Relevant Directives: Machinery Directive 2006/42/EC
RoHS-Directive 2011/65/EU

Applied standards: EN 60947-5-3:2013
EN ISO 14119:2013

Person authorised for the compilation of the technical documentation: Oliver Wacker
Möddinghofe 30
42279 Wuppertal

Place and date of issue: Wuppertal, August 3, 2020

Authorised signature
Philip Schmersal
Managing Director

BNS16-F-EN



The currently valid declaration of conformity can be downloaded from the internet at products.schmersal.com.



K.A. Schmersal GmbH & Co. KG
Möddinghofe 30, 42279 Wuppertal
Germany
Phone: +49 202 6474-0
Telefax: +49 202 6474-100
E-Mail: info@schmersal.com
Internet: www.schmersal.com