



**EN** Operating instructions. . . . . pages 1 to 4  
Original

**Content**

**1 About this document**

1.1 Function . . . . . 1

1.2 Target group: authorised qualified personnel. . . . . 1

1.3 Explanation of the symbols used . . . . . 1

1.4 Appropriate use . . . . . 1

1.5 General safety instructions . . . . . 1

1.6 Warning about misuse . . . . . 1

1.7 Exclusion of liability . . . . . 1

**2 Product description**

2.1 Ordering code . . . . . 2

2.2 Special versions. . . . . 2

2.3 Destination and use . . . . . 2

2.4 Technical data . . . . . 2

**3 Mounting**

3.1 Dimensions . . . . . 2

**4 Electrical connection**

4.1 General information for electrical connection. . . . . 3

4.2 Contact variants . . . . . 3

**5 Set-up and maintenance**

5.1 Functional testing. . . . . 3

5.2 Maintenance . . . . . 3

**6 Disassembly and disposal**

6.1 Disassembly. . . . . 3

6.2 Disposal . . . . . 3

**7 EU Declaration of conformity**

**1. About this document**

**1.1 Function**

This operating instructions manual provides all the information you need for the mounting, set-up and commissioning to ensure the safe operation and disassembly of the the product. The operating instructions must be available in a legible condition and a complete version in the vicinity of the device.

**1.2 Target group: authorised qualified personnel**

All operations described in this operating instructions manual must be carried out by trained specialist personnel, authorised by the plant operator only.

Please make sure that you have read and understood these operating instructions and that you know all applicable legislations regarding occupational safety and accident prevention prior to installation and putting the component into operation.

The machine builder must carefully select the harmonised standards to be complied with as well as other technical specifications for the selection, mounting and integration of the components.

**1.3 Explanation of the symbols used**

 **Information, hint, note:**  
This symbol is used for identifying useful additional information.

 **Caution:** Failure to comply with this warning notice could lead to failures or malfunctions.  
**Warning:** Failure to comply with this warning notice could lead to physical injury and/or damage to the machine.

**1.4 Appropriate use**

The product must be exclusively used in accordance with the versions listed below or for the applications authorised by the manufacturer. Detailed information regarding the range of applications can be found in the chapter "Product description".

**1.5 General safety instructions**

The user must observe the safety instructions in this operating instructions manual, the country-specific installation standards as well as all prevailing safety regulations and accident prevention rules.

 Further technical information can be found in the Schmersal catalogues or in the online catalogue on the Internet: [www.schmersal.net](http://www.schmersal.net).

The information contained in this operating instructions manual is provided without liability and is subject to technical modifications. There are no residual risks, provided that the safety instructions as well as the instructions regarding mounting, commissioning, operation and maintenance are observed.

**1.6 Warning about misuse**

 In case of inadequate or improper use or manipulations of the component, personal hazards or damage to machinery or plant components cannot be excluded.

**1.7 Exclusion of liability**

We shall accept no liability for damages and malfunctions resulting from defective mounting or failure to comply with this operating instructions manual. The manufacturer shall accept no liability for damages resulting from the use of unauthorised spare parts or accessories.

For safety reasons, invasive work on the device as well as arbitrary repairs, conversions and modifications to the device are strictly forbidden; the manufacturer shall accept no liability for damages resulting from such invasive work, arbitrary repairs, conversions and/or modifications to the device.

### 2. Product description

#### 2.1 Ordering code

This operating instructions manual applies to the following types:

NKF①-②Z-③-④

No.	Option	Description
①	1	1 pedal
	2	2 pedals
	3	3 pedals
②		per pedal (divided by /):
	1PW	1 change-over contact
	2PW	2 change-over contacts (only for 1- / 2-pedal versions)
	10	1 NO contact
③	20	2 NO contact
	B	Cable entry back
	L	Cable entry left
	R	Cable entry right
④	2M	with connecting cable, 2 m

#### 2.2 Special versions

For special versions, which are not listed in the order code below 2.1, these specifications apply accordingly, provided that they correspond to the standard version.

#### 2.3 Destination and use

These robust foot switches are particularly suitable for industrial applications.

#### 2.4 Technical data

Standards:	IEC 60947-5-1
Enclosure:	shock-resistant thermoplastic
Pedal:	ABS thermoplastic
Contact material:	Silver
Switching system:	snap action
Connection:	cable
Cable section:	
- Cable:	0.5 mm <sup>2</sup>
Protection class:	to IEC 60529;
- Design with cable:	IP67
Degree of pollution:	3
Utilisation category:	AC-15 / DC-13
Rated operating current/voltage $I_n/U_n$ :	2.5 A / 240 VAC; 1 A / 24 VDC
Rated impulse withstand voltage $U_{imp}$ :	2.5 kV
Rated insulation voltage $U_i$ :	250 V
Thermal test current $I_{th}$ :	4 A
Max. fuse rating:	4 A gG D-fuse (EN 60269-1)
Ambient temperature:	-25 °C ... +60 °C
Mechanical life:	1 million operations

 Enclosure rating Type 1.

### 3. Mounting

#### 3.1 Dimensions

All measurements in mm.

##### NKF

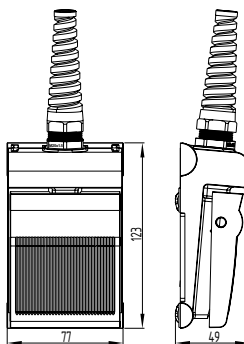

##### NKF2

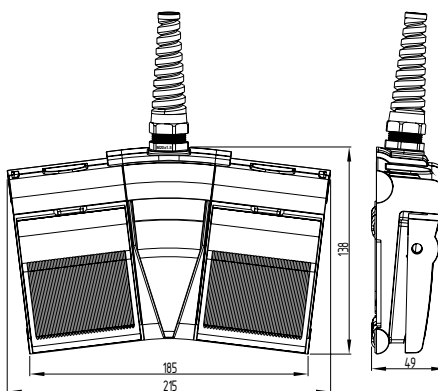

##### NKF3

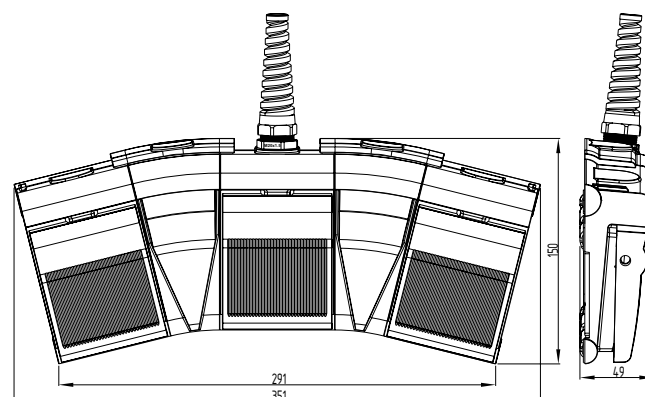

### 4. Electrical connection

#### 4.1 General information for electrical connection



The electrical connection may only be carried out by authorised personnel in a de-energised condition.

For variants with cable gland, the contact description can be found in the wiring compartment. For cable entries, please use the supplied cable glands. The cables must be laid correctly in the wiring compartment of the switch. After wiring, the wiring compartment of the switch must definitely be cleaned (e.g. removal of cables residues), considering that foreign bodies can affect the switching behaviour.

#### 4.2 Contact variants

The contacts are shown in a non-actuated condition.

#### NKF

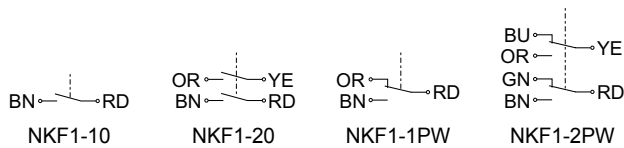

#### NKF2

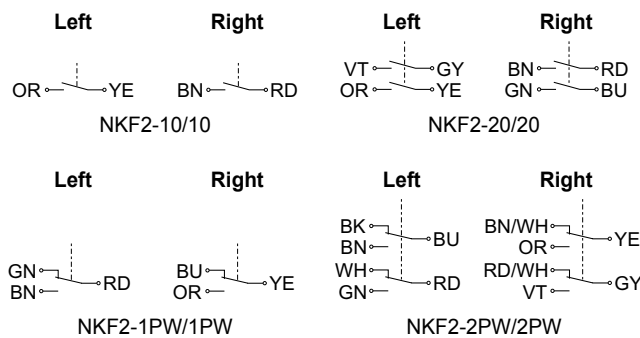

#### NKF3

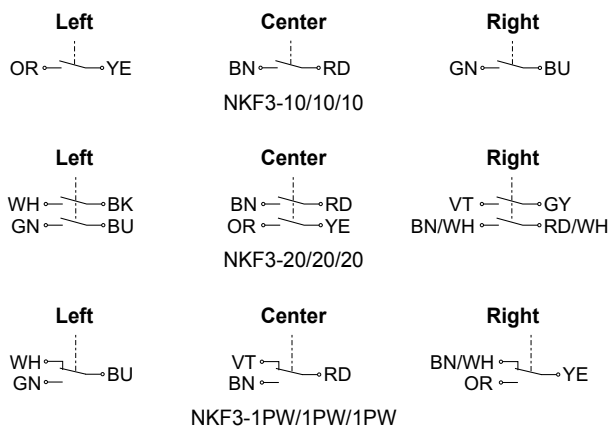

#### Colour code key

Code	Colour	Code	Colour	Code	Colour	Code	Colour
BK	Black	GN	green	RD	red	YE	yellow
BN	brown	GY	grey	VT	violet		
BU	blue	OR	orange	WH	white		

### 5. Set-up and maintenance

#### 5.1 Functional testing

The function of the component must be tested. The following conditions must be previously checked and met:

1. Check the integrity of the cable entry and connections
2. Check the switch enclosure for damage
3. Check the functionality of the switch by actuating the foot switch

#### 5.2 Maintenance

The function (switching) of the foot switch must be tested in regular intervals. Possible soiling accumulated below the foot pedal must be removed.

A regular visual inspection and functional test, including the following steps, is recommended:

- Check the switch enclosure for damages
- Check the cable entries and the wire connections

**Damaged or defective components must be replaced.**

### 6. Disassembly and disposal



#### 6.1 Disassembly

The product must be disassembled in a de-energised condition only.

#### 6.2 Disposal

The product must be disposed of in an appropriate manner in accordance with the national prescriptions and legislations.

7. EU Declaration of conformity

<b>EU Declaration of conformity</b>		
Original	ACE Schmersal Eletroeletrônica Industrial Ltda. Av. Brasil, nº 815 Jardim Esplanada CEP: 18550-000 Boituva – SP Brasil Internet: www.schmersal.com.br	
We hereby certify that the hereafter described components both in their basic design and construction conform to the applicable European Directives.		
<b>Name of the component:</b>	NKF	
<b>Type:</b>	See ordering code	
<b>Description of the component:</b>	Foot switch	
<b>Relevant Directives:</b>	Low Voltage Directive RoHS-Directive	2014/35/EU 2011/65/EU
<b>Applied standards:</b>	DIN EN 60947-5-1:2010	
<b>Place and date of issue:</b>	Boituva, January 5, 2017	
		
	Authorised signature <b>Marco Antonio De Dato</b> Head of Engineering and Design	

NKF-D-EN



The currently valid declaration of conformity can be downloaded from the internet at [www.schmersal.net](http://www.schmersal.net).

