



EN Operating instructions.pages 1 to 8
Original

Content

1 About this document

1.1 Function 1

1.2 Target group: authorised qualified personnel. 1

1.3 Explanation of the symbols used 1

1.4 Appropriate use 1

1.5 General safety instructions 1

1.6 Warning about misuse 2

1.7 Exclusion of liability 2

2 Product description

2.1 Ordering code 2

2.2 Special versions. 2

2.3 Purpose 2

2.4 Technical data 2

2.5 Classification 2

3 Mounting

3.1 General mounting instructions 3

3.2 Dimensions 3

3.3 Actuating elements mounting instructions 4

4 Electrical connection

4.1 General information for electrical connection. 4

4.2 Contact variants 5

4.3 Adjustable switching points 5

4.4 Indicator lamp connection 5

4.5 Accessories for cable entry 5

4.6 Assembly of the Dupline® input module 6

4.7 Dupline® system components 6

5 Set-up and maintenance

5.1 Functional testing. 6

5.2 Maintenance 6

6 Disassembly and disposal

6.1 Disassembly. 6

6.2 Disposal 6

7 EU declaration of conformity

1. About this document

1.1 Function
This operating instructions manual provides all the information you need for the mounting, set-up and commissioning to ensure the safe operation and disassembly of the safety switchgear. The operating instructions must be available in a legible condition and a complete version in the vicinity of the device.

1.2 Target group: authorised qualified personnel
All operations described in this operating instructions manual must be carried out by trained specialist personnel, authorised by the plant operator only.

Please make sure that you have read and understood these operating instructions and that you know all applicable legislations regarding occupational safety and accident prevention prior to installation and putting the component into operation.

The machine builder must carefully select the harmonised standards to be complied with as well as other technical specifications for the selection, mounting and integration of the components.

1.3 Explanation of the symbols used

 **Information, hint, note:**
This symbol is used for identifying useful additional information.

 **Caution:** Failure to comply with this warning notice could lead to failures or malfunctions.
Warning: Failure to comply with this warning notice could lead to physical injury and/or damage to the machine.

1.4 Appropriate use
The products described in these operating instructions are developed to execute safety-related functions as part of an entire plant or machine. It is the responsibility of the manufacturer of a machine or plant to ensure the correct functionality of the entire machine or plant.

The product must be exclusively used in accordance with the versions listed below or for the applications authorised by the manufacturer. Detailed information regarding the range of applications can be found in the chapter "Product description".

1.5 General safety instructions
The user must observe the safety instructions in this operating instructions manual, the country specific installation standards as well as all prevailing safety regulations and accident prevention rules.

 Further technical information can be found in the Schmersal catalogues or in the online catalogue on the Internet: products.schmersal.com.

The information contained in this operating instructions manual is provided without liability and is subject to technical modifications.

There are no residual risks, provided that the safety instructions as well as the instructions regarding mounting, commissioning, operation and maintenance are observed.

1.6 Warning about misuse



In case of inadequate or improper use or manipulations of the component, personal hazards or damage to machinery or plant components cannot be excluded.

1.7 Exclusion of liability

We shall accept no liability for damages and malfunctions resulting from defective mounting or failure to comply with this operating instructions manual. The manufacturer shall accept no liability for damages resulting from the use of unauthorised spare parts or accessories.

For safety reasons, invasive work on the device as well as arbitrary repairs, conversions and modifications to the device are strictly forbidden; the manufacturer shall accept no liability for damages resulting from such invasive work, arbitrary repairs, conversions and/or modifications to the device.

2. Product description

2.1 Ordering code

This operating instructions manual applies to the following types:

BS65①-②-③-④

No.	Option	Description
①	5	Grey cast iron, painted
	6	Thermosetting resin
②	Z22	Snap action, 2 NO contacts / 2 NC contacts
	T22	Slow action, 2 NO contacts / 2 NC contacts
	Z33	Snap action, 3 NO contacts / 3 NC contacts
	T33	Slow action, 3 NO contacts / 3 NC contacts
③		without indicator lamp
	G024	Indicator lamp (only for Z/T22), red (24 VDC)
	G115	Indicator lamp (only for Z/T22), red (115 VAC)
	G230	Indicator lamp (only for Z/T22), red (230 VAC)
④		Standard version (without Dupline® input module)
	DN	With integrated Dupline® input module

The devices are modular and supplied without actuating elements. A range of functions can be mapped through combination with a specific actuating element.

Actuator elements

Position switch lever (roller diameter 50 mm)

BS-H50-110-RKS	Stainless steel lever with plastic roller
BS-H50-110-RVA	Stainless steel lever with stainless steel roller

Belt misalignment lever (running surface 150 mm)

BS-B30-150-RVA	Stainless steel lever with 30 mm stainless steel roller for belt speeds to 3 m/s
BS-B50-150-RVA	Stainless steel lever with 50 mm stainless steel roller for belt speeds to 6 m/s
BS-B90-150-RVA	Stainless steel lever with 90 mm stainless steel roller for belt speeds to 12 m/s



Only if the modifications described in these operating instructions are carried out correctly is the function and therefore compliance with the Machinery Directive maintained.

2.2 Special versions

For special versions, which are not listed in the order code below 2.1, these specifications apply accordingly, provided that they correspond to the standard version.

2.3 Purpose

Position switches are used wherever moving parts on machinery and plants need to be positioned, controlled and monitored.

Belt alignment switches monitor belt alignment in material handling plants and are arranged in pairs on either side of the transported material, close to the drive rollers and pulleys. In the event of deviations on the conveyor belt, a staggered signal is generated as a pre-warning or to shut off the conveyor belt (see switching angle diagram).

On the Dupline® version, the switch statuses are queried via the two-channel Dupline® input module and transmitted via the Dupline® 2-wire installation bus to a control unit.



After installing the Dupline® input module, the technical data for the whole device must be observed. For details, please refer to the operating instructions of the Dupline® input module in the online catalogue at www.schmersal.net.

2.4 Technical data

Standards:	IEC 60947-5-1, EN 620
Enclosure/cover:	BS655: grey cast iron, painted; BS656: thermosetting resin
Protection class:	IP66, IP67 to IEC 60529
Protection class BS655 or BS656:	I or II, <input type="checkbox"/>
Degree of pollution:	3
Contact material:	Silver
Contact type:	change-over contact with double break Zb, max. 3 NO / 3 NC contacts
Switching system:	⊖ IEC 60947-5-1; snap action/slow action, positive break NC contact
Termination:	terminal strip, screw connection
Cable section:	single-wire and fine-wire with wire end ferrules
- Central connection terminal strip:	0.5 to 2.5 mm ²
- Screw connection, switching elements:	0.5 to 1.5 mm ²
Cable entry:	2 x M25
Rated impulse withstand voltage U _{imp} :	4 kV
Rated insulation voltage U _i :	300 V
Thermal test current I _{the} :	6 A
Utilisation category:	DC-13, AC-15
Rated operating current/voltage I _e /U _e :	3 A / 24 VDC 3 A / 230 VAC
Max. fuse rating:	6 A gG D-fuse
Required short-circuit current:	400 A
Ambient temperature:	-40 °C to +70 °C
- with indicator lamp:	-25 °C to +60 °C
Mechanical life:	1,000,000 operations at maximum 45° leverage deflection
Indicator lamp (optional):	LED red 24 V DC, 115 V AC, 230 V AC
Lever adjustability:	in 10° increments
Maximum lever deflection:	80

Divergent data for the Dupline® version -DN

Supply voltage:	8.2 VDC
Power consumption:	100 µA
Device insulation:	internal short-circuit proof
Rated impulse withstand voltage U _{imp} :	800 V
Rated insulation voltage U _i :	30 VDC
Cable section:	
- Rigid:	0.2 ... 4 mm ²
- Flexible with conductor ferrule:	0,25 ... 2,5 mm ²

2.5 Classification

Standards:	ISO 13849-1
B _{10D} (NC contact):	2,000,000
Service life:	20 years

(Determined values can vary depending on the application-specific parameters h_{op}, d_{op} and t_{cycle} as well as the load.)

If multiple safety components are wired in series, the Performance Level to ISO 13849-1 will be reduced due to the restricted error detection under certain circumstances.

3. Mounting

3.1 General mounting instructions



The installation may only be carried out with the system de-energised and by authorised personnel.

Two mounting holes are available.

Belt alignment switches are arranged in pairs on either side of the transported material, close to the drive rollers and pulleys. It must be ensured that the belt alignment lever is affixed at a distance of 10 - 20 mm from the transported material.



All switchgear satisfy the requirements for safety switches with positive break contacts in accordance with IEC 60957-5-1 as well as form fit over the toothed shaft between the basic component and all actuating elements. The corresponding positive break angles can be found in the switch travel diagram under 4.2.

3.2 Dimensions

All measurements in mm.

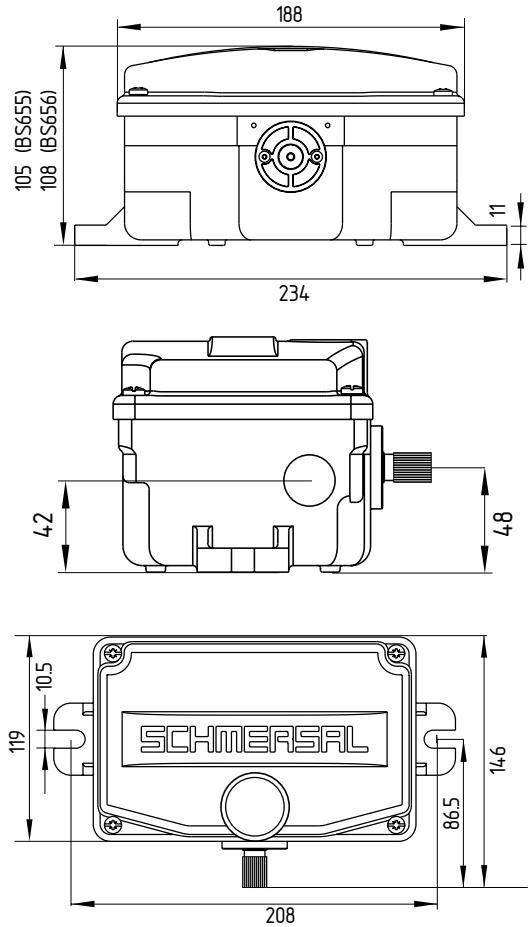

BS-H50-110-RKS
BS-H50-110-RVA

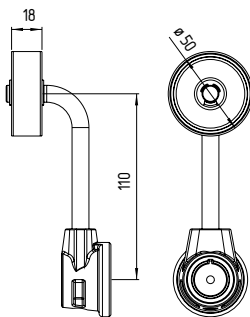

BS-B30-150-RVA

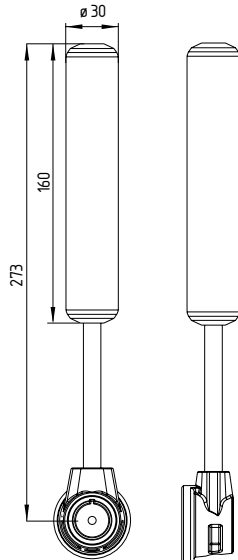

BS-B50-150-RVA

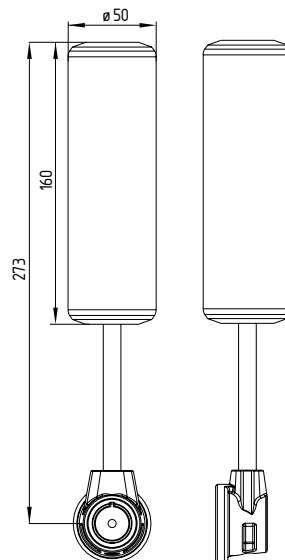

BS-B90-150-RVA

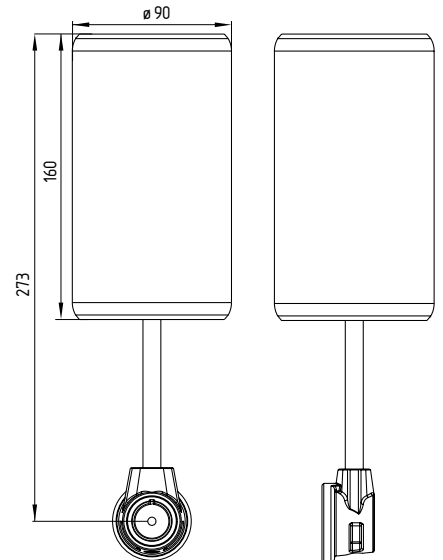

3.3 Actuating elements mounting instructions

Position the actuating element in the desired position (adjustable in 10 increments) on the toothed shaft of the basic switch and secure with the hexagon socket screw supplied. Tightening torque: 1 Nm

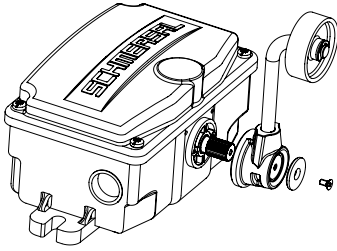

The maximum lever deflection is 80°.

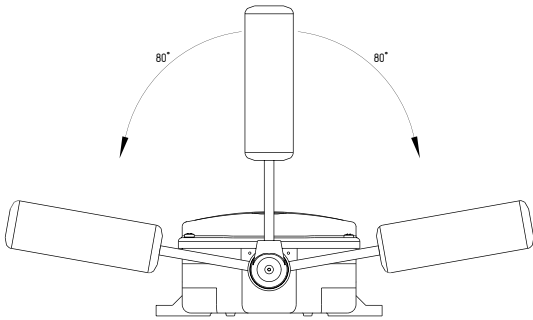

4. Electrical connection

4.1 General information for electrical connection



The electrical connection may only be carried out by authorised personnel in a de-energised condition.

Screw connection,
switching element:
0.5 ... 1.5 mm²

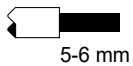

Central connection
terminal strip:
0.5 ... 2.5 mm²

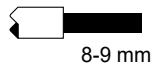

For the cable entry, suitable cable glands with an appropriate degree of protection must be used. To protect the device against condensation caused by large temperature fluctuations, we recommend the use of a pressure compensation element. Any inlet openings not used are to be sealed with a sealing screw with suitable protection.

Once wired, fit the housing cover and tighten the screws evenly (tightening torque 3 Nm).



The series has a closed switching insert cover (see Figure 2) for the selector shaft, cams and switching contacts. Once the wiring has been completed, it is absolutely necessary to use the switching insert cover and, in addition to the constructive cable routing, also serves as protection against dust and dirt.

-22: Version for wiring to a central connection terminal

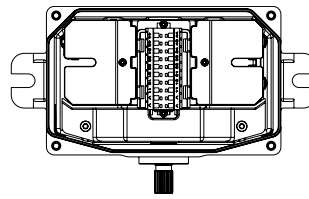

Figure 1

-33: Version for wiring to a central connection terminal

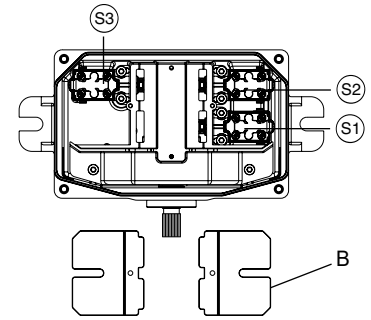

Figure 2

B: Switch insert covers



To prevent damage to the cable due to mechanical influences, the routing of a cable reserve in the free space under the switch insert cover is not permitted.

In the as-delivered condition, versions with 2 normally-open contacts and 2 normally-closed contacts (Z22, T22) have the two NO and NC contacts positioned on one side of the central connection terminal strip. The other side of the terminal strip is for the user-side connection.

The connection diagram for all versions with central connection terminal can be found in the cover of the switch. In addition to the switch contacts, terminals ("signal return") are also available for return of the signal lines when series-wiring is used.

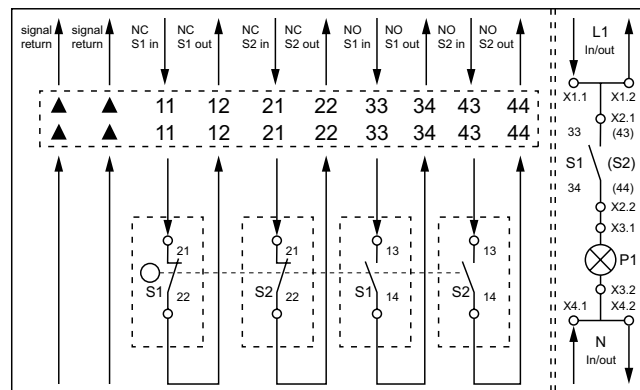

Figure 3

Versions with 3 NO contacts and 3 NC contacts do not have a central connection terminal strip. Connection is directly to the switch elements S1, S2 and S3. When routing, the individual wires should be bundled (cable ties are provided).

4.2 Contact variants

All NC contacts have positive break ⊖.

2 NO / 2 NC

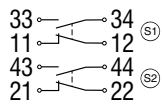

Snap action -Z22

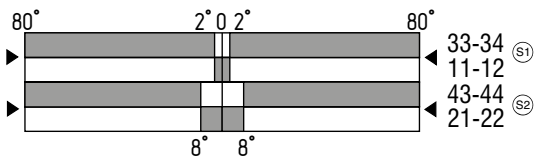
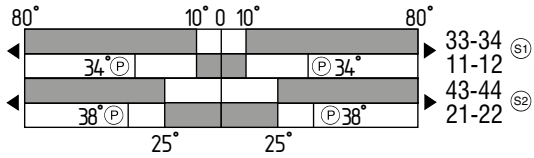

Slow action -T22

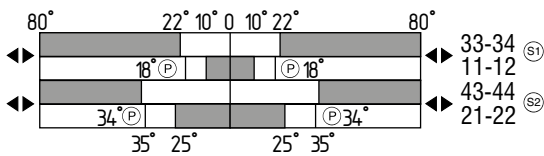

3 NO / 3 NC

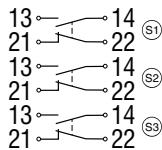

Snap action -Z33

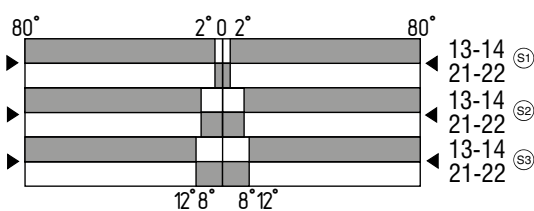
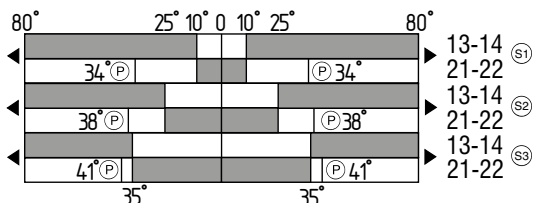

Slow action -T33

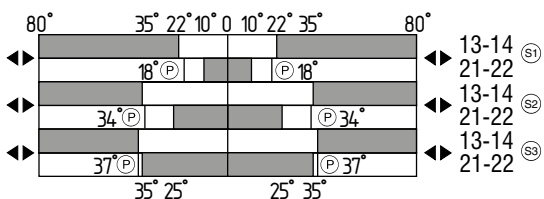

Key:

- Ⓢ1, Ⓢ2, Ⓢ3 Switch insert S1, S2, S3
- Contact closed
- Contact open
- Ⓢ Positive break angle

4.3 Adjustable switching points

Authorised specialist personnel can adjust the pre-set switching points between 10° and 35°. To do this, the dial on the respective switching element needs to be moved into the desired position.

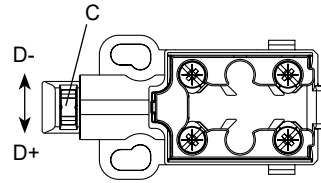

C: Adjustment wheel
 D: Switching angle

Setting the switching angle on the adjustment wheel

(Smaller switching angles are set analogously in direction D-).

Switching element		2 rotations in direction D+	Additional 1.5 rotations in direction D+
Ⓢ1	10°	25°	35°
Ⓢ2	10°	25°	35°
Ⓢ3	10°	25°	35°

■ Switching angle in as-delivered condition

4.4 Indicator lamp connection

The indicator lamp must be connected to terminals X3.1 and X3.2. (see image 3). The indicator lamp is switched via the normally-open contact of switching element S1, positioned on terminals X2.1 and X2.2 (optionally via the normally-open contact of switching element S2).

The respective potential (X1/X4) can be looped to the device next via the connection on the integrated circuit board.

4.5 Accessories for cable entry

Accessories for cable entry	Ordering code	Tightening torque
Cable gland, nickel plated brass:		
ACC-CGLD-M25-MS	103006012	8 Nm
ACC-CGLD-P-M25-MS	103031489	10 Nm
with pressure compensation element		
Screw plug, nickel plated brass:		
ACC-BPL-M25-MS	103006010	8 Nm
Cable gland, plastic:		
ACC-CGLD-M25	103032752	10 Nm
ACC-CGLD-P-M25	103031491	10 Nm
with pressure compensation element		
Screw plug, plastic:		
ACC-BPL-M25	103032753	10 Nm

4.6 Assembly of the Dupline® input module

Before electrical installation, the Dupline® input module must be addressed and parametrised in accordance with the specifications of Dupline® (www.dupline.com).

Release the connector on the circuit board with Dupline® input module connection and connect it to the programming device with the aid of the ACC-PRGC-DN programming cable. After successful addressing, the connector must be plugged back into the address bar.

Cable Dupline®

Rigid wire: 0.2 - 4 mm²

Flexible wire: 0.25 - 2.5 mm²

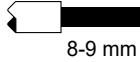

Connect the wires of the Dupline® installation bus to the dedicated terminals marked with DUP+ / DUP-. The terminals marked with DUP+ / DUP- on the side serve as a means of connection to the next Dupline® bus subscribers.

The two normally-closed contacts of the switch elements are already connected to the Dupline® input module.

For correct operation, the installation regulations of the Dupline® input module must be observed. For supply and also addressing of the Dupline® input modules, the following Dupline® system components are required.

4.7 Dupline® system components

Dupline® system components	Ordering code
Hand-held programming device GAP1605	103010199
Test unit GTU8	103013800
Programming cable ACC-PRGC-DN	103033601
Dupline® master channel generator SD2DUG24	103033128
Cable termination DT01	103010203

5. Set-up and maintenance

5.1 Functional testing

The function of the component must be tested. The following conditions must be previously checked and met:

1. Correct fixing
2. Check the integrity of the cable entry and connections
3. Check the functionality of the switch and, if applicable, the adjusted switching angle

5.2 Maintenance

In case of correct installation in accordance with the above-described instructions, the component requires little maintenance. For use in extreme conditions, we recommend routine maintenance including the following steps:

1. Actuate the lever to check its free movement
2. Remove particles of dust and soiling
3. Check cable entry and connections

Damaged or defective components must be replaced.

6. Disassembly and disposal

6.1 Disassembly

The switch must be disassembled in a de-energised condition only.

6.2 Disposal

The switch must be disposed of in an appropriate manner in accordance with the national prescriptions and legislations.

7. EU declaration of conformity

EU Declaration of conformity



Original SCHMERSAL
Industrial Switchgear (Shanghai) Co., Ltd.
Cao Ying Road 3336
201712 Shanghai / Qingpu
P.R.CHINA
<http://www.schmersal.com.cn>

We hereby certify that the hereafter described components both in their basic design and construction conform to the applicable European Directives.

Name of the component: BS655 / BS656

Type: See ordering code

Description of the component: Position switch / Belt alignment switch
(optionally with integrated Dupline® input module¹⁾)

Relevant Directives: 2006/42/EC Machinery Directive
2014/30/EU ¹⁾EMC Directive
2011/65/EU RoHS-Directive

Applied standards: EN 60947-5-1:2017
EN ISO 13849-1:2015

Person authorised for the compilation of the technical documentation: Oliver Wacker
Mödinghofe 30
42279 Wuppertal

Place and date of issue: Shanghai, July 29, 2019

Authorised signature
Uwe Seeger
Managing Director

BS655-BS656-A-DE



The currently valid declaration of conformity can be downloaded from the internet at products.schmersal.com.



K.A. Schmersal GmbH & Co. KG
Mödinghofe 30, 42279 Wuppertal
Germany

Phone: +49 202 6474-0
Fax: +49 202 6474-100
E-Mail: info@schmersal.com
Internet: www.schmersal.com

Production site:

SCHMERSAL

Industrial Switchgear (Shanghai) Co., Ltd.

Cao Ying Road 3336
201712 Shanghai / Qingpu, P.R.CHINA

Phone: +86 21 63758287
Fax: +86 21 69214398
E-Mail: info@schmersal.com.cn
Internet: www.schmersal.com.cn

施迈赛工业开关制造（上海）有限公司

地址：上海市青浦区漕盈路3336号
邮编：201712

电话：021 63758287
传真：021 69214398

网址 www.schmersal.com.cn