

Key transfer system

EX-SHGV-...-2G/D

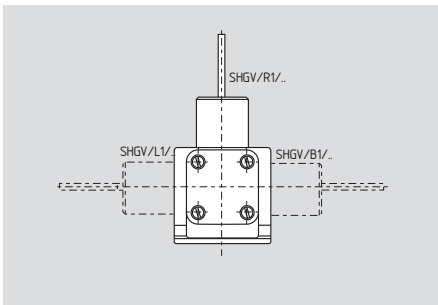
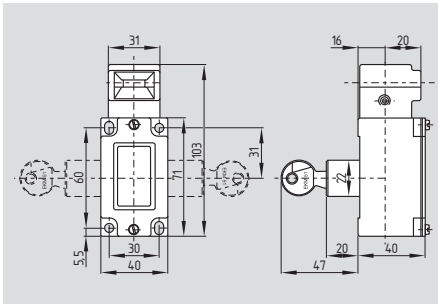

- Ex certified
- Mounting details to EN 50041
- Metal enclosure
- Oil and petroleum resistant

EX-SHGV-...-2G/D

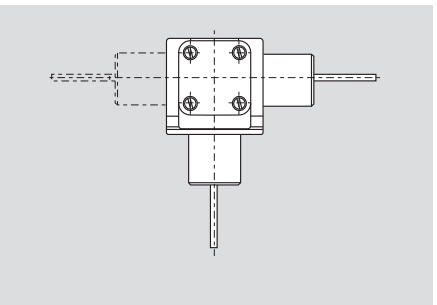
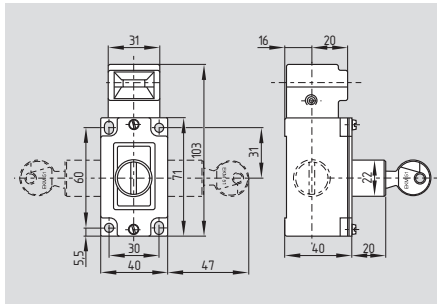

- with a second lock barrel

Technical data

Equipment category: Ex II 2GD
 Ex protection: $c 85^{\circ}\text{C X}$
 Standards: EN 13463-1, EN 61241-0
 Design: fixings to EN 50041
 Enclosure: Al Si12 die-casting, painted
 Impact energy: protection must be provided in fitted position
 Actuating speed: max. 1 m/s
 Mechanical life: 10 million operations

Approvals



Approvals



Ordering details

EX-SHGV/①01/②+③-2G/D

No.	Replace	Description
①	B L R	Cylinder lock on the back Cylinder lock on LHS Cylinder lock on RHS
②	e.g. 201	individual key numbers
③	e.g. EX-BO	Actuator range from page 67

EX-SHGV/①D1/②/③+④-2G/D

No.	Replace	Description
①	L R	Cylinder lock on LHS Cylinder lock on RHS
②	e.g. 201	individual key number for LHS or RHS cylinder lock
③	e.g. 34	individual key number for second cylinder lock
④	e.g. EX-BO	Actuator range from page 67

Key transfer system

System components

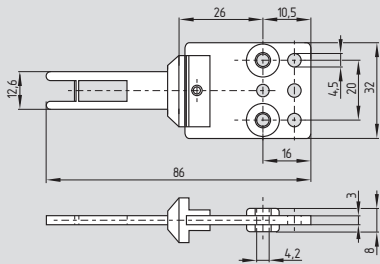

Straight actuator EX-BO

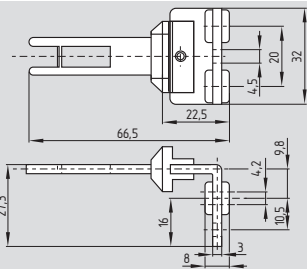

Angled actuator EX-BOW

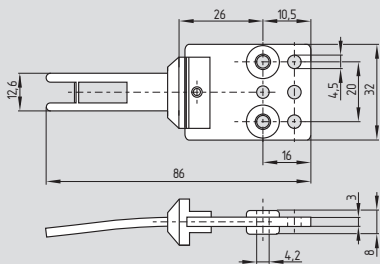

Straight radius actuator EX-BOR

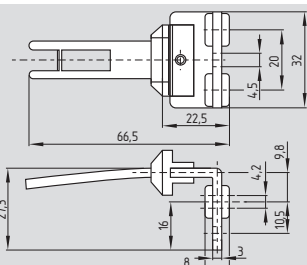

Angled radius actuator EX-BOWR

Ordering details

Straight actuator	EX-BO
Angled actuator	EX-BOW
Straight radius actuator	EX-BOR
Angled radius actuator	EX-BOWR