



**EN** Operating instructions. . . . .pages 1 to 4  
Original

**Content**

**1 About this document**

1.1 Function . . . . . 1

1.2 Target group: authorised qualified personnel. . . . . 1

1.3 Explanation of the symbols used . . . . . 1

1.4 Appropriate use . . . . . 1

1.5 General safety instructions . . . . . 1

1.6 Warning about misuse . . . . . 1

1.7 Exclusion of liability . . . . . 1

**2 Product description**

2.1 Ordering code . . . . . 2

2.2 Special versions. . . . . 2

2.3 Purpose . . . . . 2

2.4 Technical data . . . . . 2

**3 Mounting**

3.1 General mounting instructions . . . . . 2

3.2 Mounting set-up . . . . . 2

3.3 Dimensions . . . . . 3

**4 Electrical connection**

4.1 General information for electrical connection. . . . . 3

4.2 Contact variants . . . . . 3

**5 Set-up and maintenance**

5.1 Functional testing. . . . . 3

5.2 Maintenance . . . . . 3

**6 Disassembly and disposal**

6.1 Disassembly. . . . . 3

6.2 Disposal . . . . . 3

**7 EU declaration of conformity**

**1. About this document**

**1.1 Function**

This operating instructions manual provides all the information required for the mounting, set-up and commissioning to ensure the safe operation and disassembly of the switchgear. The operating instructions must be available in a legible condition and a complete version in the vicinity of the device.

**1.2 Target group: authorised qualified personnel**

All operations described in this operating instructions manual must be carried out by trained specialist personnel, authorised by the plant operator only.

Please make sure that you have read and understood these operating instructions and that you know all applicable legislations regarding occupational safety and accident prevention prior to installation and putting the component into operation.

The machine builder must carefully select the harmonised standards to be complied with as well as other technical specifications for the selection, mounting and integration of the components.

**1.3 Explanation of the symbols used**



**Information, hint, note:**

This symbol is used for identifying useful additional information.



**Caution:** Failure to comply with this warning notice could lead to failures or malfunctions.

**Warning:** Failure to comply with this warning notice could lead to physical injury and/or damage to the machine.

**1.4 Appropriate use**

The Schmersal range of products is not intended for private consumers.

The product must be exclusively used in accordance with the versions listed below or for the applications authorised by the manufacturer. Detailed information regarding the range of applications can be found in the chapter "Product description".

**1.5 General safety instructions**

The user must observe the safety instructions in this operating instructions manual, the country specific installation standards as well as all prevailing safety regulations and accident prevention rules.



Further technical information can be found in the Schmersal catalogues or in the online catalogue on the Internet: [products.schmersal.com](http://products.schmersal.com).

The information contained in this operating instructions manual is provided without liability and is subject to technical modifications.

There are no residual risks, provided that the safety instructions as well as the instructions regarding mounting, commissioning, operation and maintenance are observed.

**1.6 Warning about misuse**



In case of inadequate or improper use or manipulations of the component, personal hazards or damage to machinery or plant components cannot be excluded.

**1.7 Exclusion of liability**

We shall accept no liability for damages and malfunctions resulting from defective mounting or failure to comply with this operating instructions manual. The manufacturer shall accept no liability for damages resulting from the use of unauthorised spare parts or accessories.

For safety reasons, invasive work on the device as well as arbitrary repairs, conversions and modifications to the device are strictly forbidden; the manufacturer shall accept no liability for damages resulting from such invasive work, arbitrary repairs, conversions and/or modifications to the device.

## 2. Product description

### 2.1 Ordering code

This operating instructions manual applies to the following types:

#### TQ 700-①

No.	Option	Description
①	11	1 NO/1 NC
	02	2 NC
	20	2 NO

### 2.2 Special versions

For special versions, which are not listed in the order code below 2.1, these specifications apply accordingly, provided that they correspond to the standard version.

### 2.3 Purpose

Pull-wire switches are used on machinery and plants, where triggering the switching command must be enabled at arbitrary points on the wire run. If the tensioned pull-wire is pulled or in case of wire breakage, the switching function of the pull-wire switch is activated. (refer to image 1).

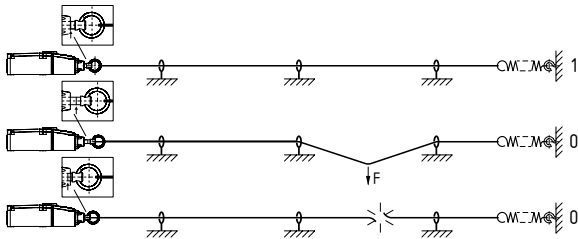

Image 1: position indication and actuation

### Design/operating principle

The pull-wire switches are brought into the operational condition by the proper pre-tensioning of a maximum 10 m long wire. The inner switching element has 2 contacts; in a tensioned condition, the NC contacts are closed and the NO contacts are open.



The pull-wire switch does not meet the requirements of the standards EN ISO 13850 and EN 60947-5-5.

### 2.4 Technical data

Standards:	EN 60947-5-1
Enclosure:	thermoplastic
Cover:	thermoplastic
Degree of protection:	IP67
Protection rating:	II, □
Degree of pollution:	3
Contact material:	Silver
Switching system:	slow action with double break, NC contact with positive break ⊖
Connection:	screw terminals
Cable section:	max. 2.5 mm <sup>2</sup> (incl. conductor ferrules)
Cable entry:	1 x M20 x 1.5
Rated impulse withstand voltage $U_{imp}$ :	6 kV
Rated insulation voltage $U_i$ :	500 V
Thermal test current $I_{the}$ :	10 A
Rated operating current/voltage $I_e/U_e$ :	4 A / 230 VAC, 4 A / 24 VDC

Utilisation category:	AC-15, DC-13
Required short-circuit current:	1,000 A
Max. fuse rating:	6 A gG D-fuse
Ambient temperature:	-25 °C ... +70 °C
Relative humidity:	30 ... 95%, no condensation, no icing
Wire length:	max. 10 m depending in relation to the range of ambient temperature (see image 4)
Mechanical life:	>1 million operations

 AWG 14, Solid/Stranded. Max. torque: 7 in. lb.  
Use copper conductors only.

## 3. Mounting

### 3.1 General mounting instructions

The installation may only be carried out by authorised personnel. The pull-wire switch is fitted by means of four screws (distance of the drill holes 30 mm or 60 mm).



The maximum perpendicular traction force to be exercised on the wire in order to activate the emergency pull-wire switch is 200 N, the maximum deflection is 400 mm. Sufficient space must be provided so that the required actuating deflection can be reached.

### 3.2 Mounting set-up

For tensioned span lengths up to 10 m, intermediate wire supports are required every 2 to 5 m. To avoid resonance vibrations in the wire on machines with high vibrations, it is recommended to realise the individual support length differently. Assembly: refer to image 2.

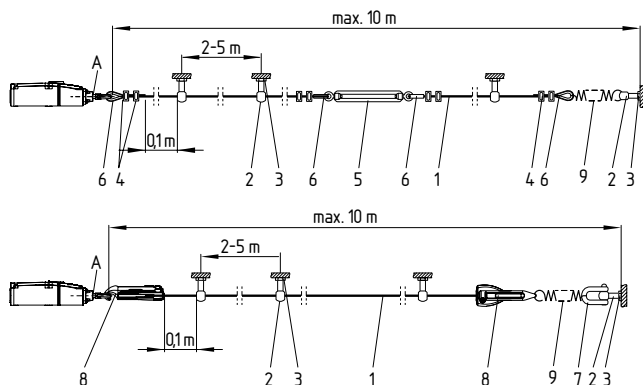

Image 2: mounting of the components

### Key

1 Pull-wire with red PVC sheath Ø 5 mm (steel core: Ø 3 mm)	6 Wire thimble
2 Eyebolt	7 Shackle
3 Nut	8 Wire tensioner S900
4 Wire clamp	9 Tension spring
5 Tensioner	A Position indication

The pull-wire must be fixed to the ring and then be pre-tensioned until the position indication is in the central position (refer to image 1).

As the thimbles are subject to deformation in case of wire pull, the wire should be pulled several times after fitting. After that, the wire must be re-tensioned (see image 3).

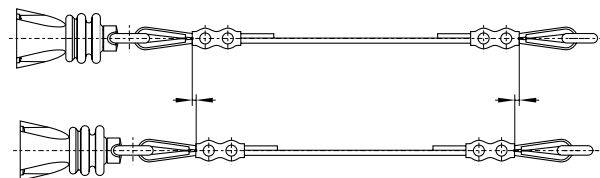

Image 3: deformation of the wire thimbles

We recommend the use of the ACC-700-RZ173 tension spring to reduce the effects of temperature variations. Due to the thermal expansion behaviour of the wire, the maximum authorised wire length is determined by the ambient temperature range (refer to image 4).



In order to ensure an optimal operation safety and to save time during fitting, we recommend using the wire rope and the combined fixing and tensioning system from Schmersal. Alternatively, wire thimbles and wire clamps can be used in conjunction with a tensioner. In this case, the red PVC sheet must be removed in the clamp area prior to installing the wire rope.

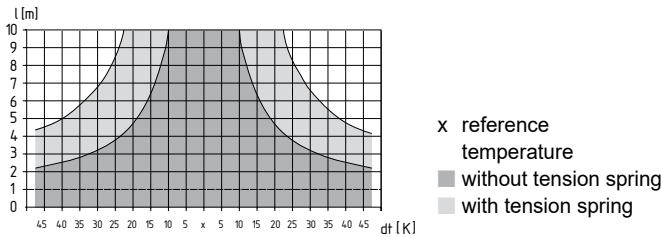
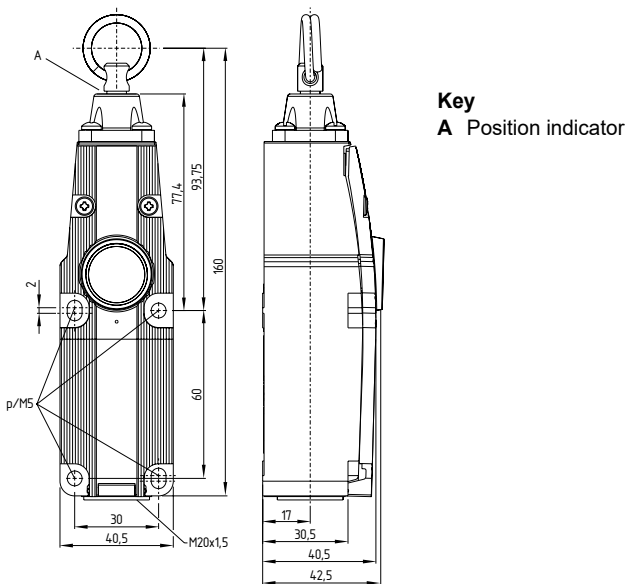

Image 4: Temperature-dependent maximum wire length with or without tension spring

### 3.3 Dimensions

All measurements in mm.

#### TQ 700



## 4. Electrical connection

### 4.1 General information for electrical connection



The electrical connection may only be carried out by authorised personnel in a de-energised condition.

Settle length  $x$  of the conductor: 6 mm



1. Cover screws must be loosened
2. Dust shield cap remove
3. Cable glands M20 x 1.5 with an appropriate degree of protection must be used
4. When wiring, please ensure that no cables are located within the range of the lever system
5. The inside of the switch must be imperatively cleaned (e.g. removal of cable residues), considering that foreign bodies can affect the switching behaviour
6. The cover screws must be tightened uniformly (tightening torque 0.5 Nm)

#### Accessories cable gland:

Ordering code: 103006013  
 Authorised cable diameter: 6 - 12 mm  
 Tightening torque: 4.5 Nm

### 4.2 Contact variants

The symbols are shown for the switch in non-actuated condition.

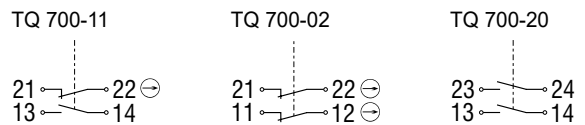

#### Key

⊖ Positive break NC contact

## 5. Set-up and maintenance

### 5.1 Functional testing

The function of the component must be tested. The following conditions must be previously checked and met:

1. Correct fixing of the pull-wire switch
2. Check the integrity of the cable entry and connections
3. Check the switch enclosure for damage
4. Check the functionality of the switch by actuating the wire
5. Check the cable tensioning by means of the position indicator

### 5.2 Maintenance

A regular visual inspection and functional test, including the following steps, is recommended:

1. Check the wire tension through the wire position indication and check the wire and the wire guides for damages and proper fitting
2. Check the functionality of the switch by actuating the wire
3. Check the cable entries and the wire connections
4. Remove particles of dust and soiling



Do not open the device when live.

**Damaged or defective components must be replaced.**

## 6. Disassembly and disposal



### 6.1 Disassembly

The switch must be disassembled in a de-energised condition only.

### 6.2 Disposal

The switch must be disposed of in an appropriate manner in accordance with the national prescriptions and legislations.

7. EU declaration of conformity

<b>EU declaration of conformity</b>		
Original	Schmersal India Private Limited G-7/1, MIDC, Ranjangaon Tal. Shirur, Dist. Pune – 412 220 Maharashtra India Internet: www.schmersal.in	
We hereby certify that the hereafter described components both in their basic design and construction conform to the applicable European Directives.		
<b>Name of the component:</b>	TQ 700	
<b>Type:</b>	See ordering code	
<b>Description of the component:</b>	Pull-wire switches	
<b>Relevant Directives:</b>	Low Voltage Directive RoHS-Directive	2014/35/EU 2011/65/EU
<b>Applied standards:</b>	EN 60947-5-1:2017 + AC:2020	
<b>Person authorised for the compilation of the technical documentation:</b>	Oliver Wacker Möddinghofe 30 42279 Wuppertal	
<b>Place and date of issue:</b>	Pune, January 19, 2024	
		
	Authorised signature <b>Sagar Jeevan Bhosale</b> Managing Director	

TQ700-D-EN-SIPL



The currently valid declaration of conformity can be downloaded from the internet at [products.schmersal.com](http://products.schmersal.com).



**K.A. Schmersal GmbH & Co. KG**  
Möddinghofe 30, 42279 Wuppertal  
Germany  
Phone: +49 202 6474-0  
Fax: +49 202 6474-100  
E-Mail: [info@schmersal.com](mailto:info@schmersal.com)  
Internet: [www.schmersal.com](http://www.schmersal.com)

**Production site:**  
**Schmersal India Private Limited**  
G-7/1, MIDC, Ranjangaon  
Taluka Shirur, Dist. Pune – 412 220  
Maharashtra  
India  
Phone: +91 21 38614700  
Fax: +91 20 66861114  
E-Mail: [info-in@schmersal.com](mailto:info-in@schmersal.com)  
Internet: [www.schmersal.in](http://www.schmersal.in)