



EN Operating instructions.pages 1 to 4
Original

Content

1 About this document

1.1 Function 1

1.2 Target group: authorised qualified personnel. 1

1.3 Explanation of the symbols used 1

1.4 Appropriate use 1

1.5 General safety instructions 1

1.6 Warning about misuse 1

1.7 Exclusion of liability 2

2 Product description

2.1 Ordering code 2

2.2 Special versions. 2

2.3 Purpose 2

2.4 Technical data 2

2.5 Safety classification 2

3 Mounting

3.1 General mounting instructions 3

3.2 Dimensions 3

4 Electrical connection

4.1 General information for electrical connection. 3

4.2 Contact variants. 3

5 Set-up and maintenance

5.1 Functional testing. 3

5.2 Maintenance 3

6 Disassembly and disposal

6.1 Disassembly. 3

6.2 Disposal 3

7 EU Declaration of conformity

1. About this document

1.1 Function

This operating instructions manual provides all the information you need for the mounting, set-up and commissioning to ensure the safe operation and disassembly of the safety switchgear. The operating instructions must be available in a legible condition and a complete version in the vicinity of the device.

1.2 Target group: authorised qualified personnel

All operations described in this operating instructions manual must be carried out by trained specialist personnel, authorised by the plant operator only.

Please make sure that you have read and understood these operating instructions and that you know all applicable legislations regarding occupational safety and accident prevention prior to installation and putting the component into operation.

The machine builder must carefully select the harmonised standards to be complied with as well as other technical specifications for the selection, mounting and integration of the components.

1.3 Explanation of the symbols used

 **Information, hint, note:**
This symbol is used for identifying useful additional information.

 **Caution:** Failure to comply with this warning notice could lead to failures or malfunctions.
Warning: Failure to comply with this warning notice could lead to physical injury and/or damage to the machine.

1.4 Appropriate use

The Schmersal delivery program is not intended for private consumers.

The products described in these operating instructions are developed to execute safety-related functions as part of an entire plant or machine. It is the responsibility of the manufacturer of a machine or plant to ensure the correct functionality of the entire machine or plant.

The safety switchgear must be exclusively used in accordance with the versions listed below or for the applications authorised by the manufacturer. Detailed information regarding the range of applications can be found in the chapter "Product description".

1.5 General safety instructions

The user must observe the safety instructions in this operating instructions manual, the country specific installation standards as well as all prevailing safety regulations and accident prevention rules.

 Further technical information can be found in the Schmersal catalogues or in the online catalogue on the Internet: products.schmersal.com.

The information contained in this operating instructions manual is provided without liability and is subject to technical modifications.

There are no residual risks, provided that the safety instructions as well as the instructions regarding mounting, commissioning, operation and maintenance are observed.

1.6 Warning about misuse

 In case of improper use or manipulation of the safety switchgear, personal hazards or damages to machinery or plant components cannot be excluded.

1.7 Exclusion of liability

We shall accept no liability for damages and malfunctions resulting from defective mounting or failure to comply with this operating instructions manual. The manufacturer shall accept no liability for damages resulting from the use of unauthorised spare parts or accessories.

For safety reasons, invasive work on the device as well as arbitrary repairs, conversions and modifications to the device are strictly forbidden, the manufacturer shall accept no liability for damages resulting from such invasive work, arbitrary repairs, conversions and/or modifications to the device.

2. Product description

2.1 Ordering code

This operating instructions manual applies to the following types:

EX-AZ 3350-12-ZUEK-①-3D

No.	Option	Description
①	U90	Actuating head can be rotated 90° for door hinge left
	U270	Actuating head can be rotated 270° for door hinge right
Actuator		- for sliding safety guards:
EX-AZ3350-B1		Straight actuator with rubber mounting
EX-AZ3350-B5		Angled actuator with rubber mounting
		- for hinged safety guards:
EX-AZ3350-B1R		Flexible actuator with rubber mounting

2.2 Special versions

For special versions, which are not listed in the order code below 2.1, these specifications apply accordingly, provided that they correspond to the standard version.

2.3 Purpose

The safety switches are suitable for sliding, hinged and removable safety guards, which need to be closed in order to ensure the necessary operational safety.

Only the above mentioned actuators are to be used to actuate the safety switch.



The safety switchgears are classified according to EN ISO 14119 as type 2 interlocking devices.

The components can be used in potentially explosive atmospheres of Zone 22 equipment category 3D. The installation and maintenance requirements to the standard series 60079 must be met.



The user must evaluate and design the safety chain in accordance with the relevant standards and the required safety level.



The entire concept of the control system, in which the safety component is integrated, must be validated to the relevant standards.

Conditions for safe operation

The specific ambient temperature range must be observed.

2.4 Technical data

Designation in accordance with the ATEX Directive:	⊕ II 3D
Designation in accordance with standards:	Ex tc IIIC T90°C Dc
Applied standards:	EN 60947-5-1, EN IEC 60079-0, EN 60079-31
Enclosure:	light-alloy diecast, paint finish
Actuator:	VA
Design:	EN 50041
Max. impact energy:	7 J
Actuating speed:	max. 1 m/s
Switching frequency:	1,200 / h
Degree of protection:	IP67 to EN 60529
	IP64 in accordance with the standard series 60079
Contact material:	Silver
Coding level according to EN ISO 14119:	low
Contact type:	Change-over with double break Zb, galvanically separated contact bridges
Applied standards:	⊖ EN 60947-5-1, slow action, NC contact with positive break
Connection:	screw terminals
Max. cable section:	0.75 ... 2.5 mm ² (incl. conductor ferrules)
Cable entry:	M20 x 1.5
Rated impulse withstand voltage U _{imp} :	4 kV
Rated insulation voltage U _i :	250 V
Thermal test current I _{the} :	10 A
Utilisation category:	AC-15 / DC-13
Rated operating current/voltage I _g /U _g :	4 A / 230 VAC 4 A / 24 VDC
Max. fuse rating:	6 A gG D-fuse
Positive break travel:	10.7 mm
Positive break force:	each NC contact 5 N
Ambient temperature:	-10°C ... +60°C
Mechanical life:	1 million operations
EX cable gland:	⊕ II 2GD
Cable cross-section of the EX cable glands:	Ø 7 ... 12 mm
Tightening torque:	
- Cover screws:	min. 1.0 Nm
- EX cable gland:	min. 8 Nm
- Earth screws:	PE 1 Nm, PA 1.2 Nm

2.5 Safety classification

Standards:	EN ISO 13849-1
Envisaged structure:	
- Basically:	applicable up to Cat. 1 / PL c
- With 2-channel usage and fault exclusion mechanism*:	applicable up to Cat. 3 / PL d with suitable logic unit
B _{10D} NC contact:	2,000,000
B _{10D} NO contact at 10% ohmic contact load:	1,000,000
Mission time:	20 years

* If a fault exclusion to the 1-channel mechanics is authorised.

$$MTTF_D = \frac{B_{10D}}{0,1 \times n_{op}} \quad n_{op} = \frac{d_{op} \times h_{op} \times 3600 \text{ s/h}}{t_{cycle}}$$

(Determined values can vary depending on the application-specific parameters h_{op}, d_{op}, t_{cycle} as well as the load.)

If multiple safety components are wired in series, the Performance Level to EN ISO 13849-1 will be reduced due to the restricted error detection under certain circumstances.

3. Mounting

3.1 General mounting instructions



Fitting is only authorised in a de-energised condition



Please observe the relevant requirements of the standards EN ISO 12100, EN ISO 14119 and EN ISO 14120.

Four mounting holes are provided for fixing the enclosure. The use of a protective ground wire is imperative. The enclosure must not be used as an end stop. Any mounting position. The mounting position must be chosen so as to avoid the penetration of dirt in the used holes.



Please observe the recommendations regarding maximum impact energy, actuating speed and tightening torque in the technical data.

Mounting of the actuators:

See operating instructions actuator EX-AZ 3350-B.



The actuator must be permanently fitted to the safety guard and protected against displacement by suitable measures (tamperproof screws, gluing, drilling of the screw heads, pinning).

3.2 Dimensions

All measurements in mm.

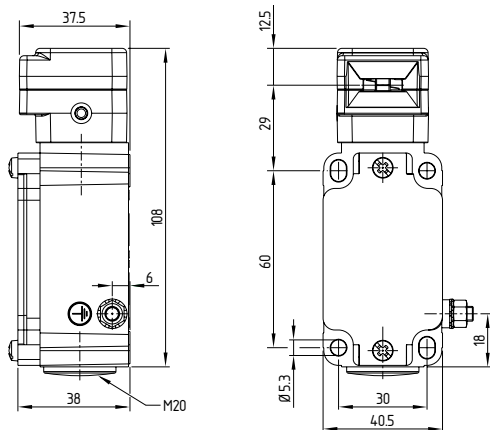

4. Electrical connection

4.1 General information for electrical connection



The electrical connection may only be carried out by authorised personnel in a de-energised condition.

The contact labelling can be found in the wiring compartment of the switch.

Settle length x of the conductor: 6 mm



The EX cable gland (included in delivery) is only authorised for permanent cables. The constructor must provide for the necessary strain relief. After wiring, dust and soiling must be removed from the wiring compartment.



Connection to the external protective conductor terminal must be carried out in accordance with EN 60079-14 section 6.3. A ring cable lug of size M5 must be used for connection of the wire.

4.2 Contact variants

Contacts are shown with safety guard closed.

1 NO / 2 NC

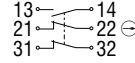

Information for the selection of suitable safety-monitoring modules can be found in the Schmersal catalogues or in the online catalogue on our website: products.schmersal.com.

5. Set-up and maintenance

5.1 Functional testing

The safety function of the safety components must be tested. The following conditions must be previously checked and met:

- The installation is executed according to the instructions
- The connection is executed correctly
- Remove particles of dust and soiling.
- Check the free movement of the actuating element.
- The safety component is not damaged.

5.2 Maintenance

In case of correct installation in accordance with the instructions described above, the component requires little maintenance. For use in extreme conditions, we recommend routine maintenance including the following steps:

1. Check the correct fixing of the actuator and the safety switchgear.
2. Remove particles of dust and soiling.
3. Check cable entry and connections in a de-energised condition



Do not open the device when live.



Adequate measures must be taken to ensure protection against tampering either to prevent tampering of the safety guard, for instance by means of replacement actuators.

For explosion protection reasons, the component must be exchanged after max. 1 million operations.

Damaged or defective components must be replaced.

6. Disassembly and disposal

6.1 Disassembly

The safety switchgear must be disassembled in a de-energised condition only.

6.2 Disposal

The safety switchgear must be disposed of in an appropriate manner in accordance with the national prescriptions and legislations.

7. EU Declaration of conformity

EU Declaration of conformity		
Original	SCHMERSAL Industrial Switchgear (Shanghai) Co., Ltd. Cao Ying Road 3336 201712 Shanghai / Qingpu P.R.CHINA Internet: www.schmersal.com.cn	
We hereby certify that the hereafter described components both in their basic design and construction conform to the applicable European Directives.		
Name of the component:	EX-AZ 3350	
Type:	See ordering code	
Marking:		
Description of the component:	Positive break position switch with separate actuator for safety functions	
Relevant Directives:	Machinery Directive Explosion Protection Directive (ATEX) RoHS-Directive	2006/42/EC 2014/34/EU 2011/65/EU
Applied standards:	EN 60947-5-1:2017 + AC:2020 EN IEC 60079-0:2018 EN 60079-31:2014	
Conformity with the explosion protection directive 2014/34/EU (ATEX) is declared by the manufacturer without involving a conformity assessment center.		
Person authorised for the compilation of the technical documentation:	Oliver Wacker Möddinghofe 30 42279 Wuppertal	
Place and date of issue:	Shanghai, January 19, 2024	
SISS-EX-AZ3350-C-EN		
	Authorised signature Michele Seassaro Managing Director	



The currently valid declaration of conformity can be downloaded from the internet at products.schmersal.com.



K.A. Schmersal GmbH & Co. KG
Möddinghofe 30, 42279 Wuppertal
Germany
Phone: +49 202 6474-0
Fax: +49 202 6474-100
E-Mail: info@schmersal.com
Internet: www.schmersal.com

Production site:
SCHMERSAL
Industrial Switchgear (Shanghai) Co., Ltd.
Cao Ying Road 3336
201712 Shanghai / Qingpu, P.R.CHINA
Phone: +86-21-63 75 82 87
Fax: +86-21-69 21 43 98
E-Mail: info@schmersal.com.cn
Internet: www.schmersal.com.cn