



EN Operating instructions. pages 1 to 14
Original

Content

1 About this document

1.1 Function 1

1.2 Target group: authorised qualified personnel. 1

1.3 Explanation of the symbols used 1

1.4 Appropriate use 1

1.5 General safety instructions 1

1.6 Warning about misuse 1

1.7 Exclusion of liability 2

2 Product description

2.1 Ordering code 2

2.2 Special versions. 3

2.3 Purpose and use 3

2.4 Intended use in hygiene-sensitive areas 3

2.5 Technical data 3

3 Mounting

3.1 General mounting instructions for H program 6

3.2 Special mounting instructions for hygiene applications 6

3.3 Dimensions 7

4 Electrical connection

4.1 General information for electrical connection. 10

5 Set-up and maintenance

5.1 Functional testing. 10

5.2 Maintenance 10

5.3 Cleaning and disinfection. 10

6 Disassembly and disposal

6.1 Disassembly devices with SMF contact carrier 12

6.2 Disassembly devices with SMF-SG-contact carrier 12

6.3 Disposal 12

7 EU Declaration of conformity

1. About this document

1.1 Function

These operating instructions provide all the information required for mounting, set-up and commissioning to ensure the safe operation and disassembly of the switchgear. The operating instructions must be available in a legible condition and a complete version in the vicinity of the device.

1.2 Target group: authorised qualified personnel

All operations described in this operating instructions manual must be carried out by trained specialist personnel, authorised by the plant operator only.

Please make sure that you have read and understood these operating instructions and that you know all applicable legislations regarding occupational safety and accident prevention prior to installation and putting the component into operation.

The machine builder must carefully select the harmonised standards to be complied with as well as other technical specifications for the selection, mounting and integration of the components.

1.3 Explanation of the symbols used



Information, hint, note:
This symbol is used for identifying useful additional information.



Caution: Failure to comply with this warning notice could lead to failures or malfunctions.
Warning: Failure to comply with this warning notice could lead to physical injury and/or damage to the machine.

1.4 Appropriate use

The Schmersal range of products is not intended for private consumers.

The products described here were developed to adopt control and display functions as part of a complete system or machine. It is the responsibility of the manufacturer of a machine or plant to ensure the correct functionality of the entire machine or plant.

The products must be exclusively used in accordance with the versions listed below or for the applications authorised by the manufacturer. Detailed information regarding the range of applications can be found in the chapter "Product description".

1.5 General safety instructions

The user must observe the safety instructions in this operating instructions manual, the country specific installation standards as well as all prevailing safety regulations and accident prevention rules.



Further technical information can be found in the Schmersal catalogues or in the online catalogue on the Internet: products.schmersal.com.

The information contained in this operating instructions manual is provided without liability and is subject to technical modifications. There are no residual risks, provided that the safety instructions as well as the instructions regarding mounting, commissioning, operation and maintenance are observed.

1.6 Warning about misuse



In case of inadequate or improper use or manipulations of the component, personal hazards or damage to machinery or plant components cannot be excluded.

1.7 Exclusion of liability

We shall accept no liability for damages or malfunctions resulting from defective mounting or failure to comply with this operating instructions manual. We shall accept no liability for damages or malfunctions resulting from defective mounting or failure to comply with this operating instructions manual.

For safety reasons, invasive work on the device as well as arbitrary repairs, conversions and modifications to the device are strictly forbidden, the manufacturer shall accept no liability for damages resulting from such invasive work, arbitrary repairs, conversions and/or modifications to the device.

2. Product description

2.1 Ordering code

This operating instructions manual applies to the following types:

2.1.1 Device heads of the command devices

Basic component	Description
Pushbuttons and the illuminated pushbuttons:	
HDT-⑤-①	Pushbutton
HDL-⑤-①	Illuminated pushbutton
Indicator light:	
HML-⑤-①	With flat collar
Mushroom head impact button:	
HDT②-⑤-①	Without latching
HDL②-⑤-①	Illuminated, without latching
HDRZ②-⑤-①	With latching, pull to unlock
Selector switch / spring-return selector switch:	
- with 2 positions:	
HWS21③-⑤-④	2 maintained positions
HWT21③-⑤-④	1 momentary position
- with 3 positions:	
HWS32③-⑤-④	3 maintained positions
HWT32③-⑤-④	2 momentary positions
HWST32③-⑤-④	Switching, latching
HWTS32③-⑤-④	Latching, switching
Step selector switch:	
HWSE⑥-③-⑤-④	-
Main switch:	
HHS⑦-⑤-SW-⑧-⑨	With black toggle and silver background
HHSNH⑦-⑤-RT-⑧-⑨	With red toggle and yellow background
Potentiometer drive:	
HDAN6⑥-④-⑩	Drive for potentiometer
Blanking plug for control unit:	
HB-⑤	Blanking plug

No.	Option	Description
①	Colour of operating and light surfaces:	
	GB	Yellow
	RT	Red
	GN	Green
	WS	White
	BL	Blue
	GR	Grey
	SW	Black (not for illuminating devices)
②	Head diameter of mushroom head impact button:	
	30	30 mm
	40	40 mm
③	Toggle length:	
	Without	Short toggle
	.1	Long toggle
④	Colour of toggle:	
	SW	Black
	WS	White
⑤	Colour of diaphragm:	
	WS	White (on request)
	SW	Black (on request)
	BL	Blue
⑥	Switching stages:	
	2	2 levels
	3	3 levels
	4	4 levels
	5	5 levels
	6	6 levels
	7	7 levels
	8	8 levels
	9	9 levels
	10	10 levels
	11	11 levels
	12	12 levels
⑦	Current:	
	16	16 ampere
	40	40 ampere
	63	63 ampere
	125	125 ampere
⑧	Number of poles:	
	without	3-pole
	2-POL	2-pole
	4-POL	4-pole
⑨	Mounting plate:	
	without	Without mounting plate
	MP	With mounting plate
⑩	End stop:	
	without	Without end stop
	250	End stop at 250°

2.1.2 Contact elements of CLP contact system

Basic component	Description
CLP101	Contact element NC (red)
CLP110	Contact element NO (green)

2.1.3 Light elements of CLP contact system

Basic component	Description
CLP001	Voltage sensor for LEDs Ba9S

2.2 Special versions

For special versions, which are not listed in the ordering code below 2.1, these specifications apply accordingly, provided that they correspond to the standard version.

2.3 Purpose and use

The devices described here are designed to be mounted in control panels or assembly housings. The command devices are only suitable for processing operation-relevant signals for purposes of machine control.



Operation of the devices in areas at risk of explosion is not intended use.

2.4 Intended use in hygiene-sensitive areas

The devices are intended for use on food-processing machinery in accordance with DIN EN 1672-2. When designing the machine or system, it must be ensured that the command devices are attached such that lateral actuation via the sealing bellows is rendered impossible, that the devices can be operated at the operating surfaces and that ergonomic operation is possible.

The plant owner must ensure that machines and systems are operated and cleaned only by personnel who have been trained on the machine or system. The machine and system owner and cleaning personnel have been instructed on the specifics of the machine and system.



Operating devices with chain gloves, blades, spatulas or similar objects is impermissible. Doing so can give rise to damage to exposed sealing elements and represents a hygiene risk.



The contact time with foodstuffs should not exceed 8 hours. Exceeding the contact time can pose a hygiene risk.



The devices must be cleaned regularly. Improper or outstanding cleaning represents an elevated hygiene risk. More information can be found in the chapter Cleaning and disinfection.

2.5 Technical data

Command and signalling devices

Standards:	EN 60947-5-1, EN 60947-1, DIN EN 1672-2
Design:	round
Connection:	central nut
Type of execution:	front plate mounting
Front plate thickness min.:	1.5 mm
Front plate thickness max.:	6 mm
Notice front plate thickness:	incl. identification label
Mounting diameter:	22.3 mm
Anti-twist safeguard, height:	1.8 mm
Anti-twist safeguard, width:	3.2 mm
Mounting recess main switch:	90 mm x 90 mm
Size mounting plate main switch:	110 mm x 110 mm
Installation position:	all surfaces min 3° to the horizontal
Spacing:	
- Push button / illuminated push button:	65 mm x 65 mm
- Mushroom head impact button,	65 mm x 65 mm
- Mushroom head impact button with latching:	65 mm x 65 mm
- Selector switch / selector button short:	65 mm x 65 mm
- Selector switch / selector button long:	65 mm x 82 mm
- Step selector switch short:	no grid mounting
- Step selector switch long:	no grid mounting
- Potentiometer drive:	no grid mounting
- Main switch:	no grid mounting
Switching frequency:	
- Devices with CLP contact system:	1,000/h

Actuating stroke NC contact:

- Push button / illuminated push button:	1.1 mm
- Mushroom head impact button:	1.4 mm
- Mushroom head impact button with latching:	3.6 mm

Actuating stroke NO contact:

- Push button / illuminated push button:	1.4 mm
- Mushroom head impact button:	1.8 mm
- Mushroom head impact button with latching:	3.9 mm

Switching angle/actuation angle NC contact:

- Selection switch/button:	25°
----------------------------	-----

Switching angle/actuation angle NO contact:

- Selector switch/button:	30°
- Step selector switch:	30°, 45°, 60°, 90°, depending on version
- Main switch:	90°

Actuating force per device:

- (Illuminated) push button:	16 N
- Mushroom button:	14 N
- Impact button with detent:	50 N
- Selector switch/button:	0.5 Nm
- Step selector switch:	depending on switch
- Potentiometer drive:	depending on potentiometer
- Main switch:	depending on load and main switch

Number of contact elements, maximum:

- Push button:	6
- Illuminated push button:	4
- Mushroom head impact button:	6
- Mushroom head impact button with illumination:	4
- Mushroom head impact button with latching:	4
- Selector switch / selector button:	4

Actuating stroke device head:

- Push button / illuminated push button:	3.5 mm
- Mushroom head impact button:	3.5 mm
- Mushroom head impact button with latching:	5.5 mm

Switching angle / actuation angle device head

- Selector switch / selector button:	45°
- Step selector switch:	depending on the number of switch positions
- Main switch:	90°
- Potentiometer drive:	250°; infinite

Mechanical lifetime:

- Push button / illuminated push button:	1,000,000 operations
- Mushroom head impact button:	1,000,000 operations
- Mushroom head impact button with latching:	100,000 operations
- Selector switch / selector button:	300,000 operations
- Step selector switch:	>1,000,000 operations
- Potentiometer drive:	-
- Main switch up to 63 A:	>100,000 operations
- Main switch 125 A:	25,000 operations

Unlocking type

- Selector switch:	twist-to-unlatch mechanism
- Mushroom head impact button with latching:	pull-to-unlatch mechanism

Release force:

- Selector switch:	0.5 Nm
- Mushroom head impact button with latching:	50 N

Material:

- Operating and display surfaces:	PA12
- Operating surface, large mushroom button:	PBT-GF30
- Toggle handle:	ABS
- Sealing elements:	silicone; HNBR
- Front ring:	stainless steel

Typing cULus: Type 4x, 5, 12, 13, Indoor

Degree of protection: IP67, IP69K

Ambient temperature device heads:

- Push button / illuminated push button:	-25 °C ... +80 °C
- Mushroom head impact button:	-25 °C ... +80 °C
- Mushroom head impact button with latching:	-25 °C ... +80 °C
- Selector switch / selector button:	0 °C ... +80 °C
- Step selector switch:	0 °C ... +80 °C
- Potentiometer drive:	0 °C ... +80 °C
- Main switch:	0 °C ... +80 °C

Storage temperature:	
- Push button / illuminated push button:	-25 °C ... +80 °C
- Mushroom head impact button:	-25 °C ... +80 °C
- Mushroom head impact button with latching:	-25 °C ... +80 °C
- Selector switch / selector button:	0 °C ... +80 °C
- Step selector switch:	0 °C ... +80 °C
- Potentiometer drive:	0 °C ... +80 °C
- Main switch	0 °C ... +80 °C
Tightening torque:	
- Blind closure:	1.8 Nm
- Central nut:	4 Nm
- Attachment nuts M5, main switch plate:	2 Nm
Contact carrier version:	
- Standard devices:	SMF
- Special devices (step selector switch, main switch and potentiometer drive):	SMF-SG
Type of contact elements, standard devices:	CLP
Resistance to shock according to EN 60068-2-27:	<50 g
Resistance to vibration according to EN 60068-2-6:	5 g
Device labelling:	laser-etched
Cleaning temperature, max.:	+80 °C
Temperature change, max.:	20 °C/min
Authorised cleaning agents:	see table chapter Cleaning
Permissible installation altitude above sea level, max.:	2,000 m
Relative humidity, max.:	93 %
	non condensing, non icing
Mission time:	20 years

Contact elements CLP110 / CLP101

Standards:	EN 60947-5-1, EN 60947-1
Material of the housings:	thermoplastic, self-extinguishing
Material of the contacts:	Carrier made from fine silver, phosphor bronze or brass
Utilisation category AC-15:	250 V / 6 A
Utilisation category DC-13:	24 V / 3 A
Rated insulation voltage U _i :	500 V
Rated impulse withstand voltage U _{imp} :	2.5 kV
Degree of pollution:	3
Overvoltage category:	III
Thermal test current I _{the} :	6 A
Max. fuse rating:	6 A gG
Climatic resistance:	to EN 60068 part 2-30
Ambient temperature:	-25 °C ... +60 °C
Storage temperature:	-25 °C ... +60 °C
Proof of positive opening:	2.5 kV impulse voltage
Positive break travel NC contact:	2 mm
Switch travel NC contact:	1 mm
Switch travel NO contact:	2 mm
Switching system:	Slow action, NC contacts with positive break
Switching elements:	Individual contacts with contact bridge
Actuating force at stroke end:	8 N
Switching frequency:	1,200/h
Mechanical lifetime: :	5,000,000 operations
Resistance to shock:	30 g / 18 ms
Resistance to vibration:	20 g / 10 ... 150 Hz
Wiring configuration:	to EN 60947-1
Connection:	screw terminals
Tightening torque for the connecting screw:	1.0 Nm
Cable section:	
- solid wire:	2x 0.5 ... 1.5 mm ²
- stranded wire incl. conductor ferrules with protective collar:	2x 0.5 ... 1.5 mm ²
Degree of protection:	
- Connections:	IP20
- Wiring compartments:	IP40
Permissible installation altitude above sea level, max.:	2,000 m
Relative humidity, max.:	93 %
	non condensing, non icing
B _{10D} -value NC contact:	100,000 operations
Mission time:	20 years
Certificates:	cULus

Light element CLP001

Standards:	EN 60947-5-1, EN 60947-1
Material of the housings:	thermoplastic, self-extinguishing
Degree of pollution:	III
Climatic resistance:	to EN 60068 part 2-30
Ambient temperature:	-25 °C ... +60 °C
Storage temperature:	-25 °C ... +60 °C
Resistance to shock:	30 g / 18 ms (observe lamp values)
Resistance to vibration:	20 g / 10 ... 150 Hz
Wiring configuration:	to EN 60947-1
Connection:	screw terminals
Tightening torque for the connecting screw:	1.0 Nm
Cable section:	
- solid wire:	2x 0.5 ... 1.5 mm ²
- stranded wire incl. conductor ferrules with protective collar:	2x 0.5 ... 1.5 mm ²
Usable illuminant:	Ba9S LED
Voltage illuminant:	24 VDC
Power illuminant, max.:	0.5 W
Degree of protection:	
- Connections:	IP20
- Socket:	IP20
Permissible installation altitude above sea level, max.:	2,000 m
Relative humidity, max.:	93 %
	non condensing, non icing
Certificates:	cULus



- Field wiring terminals: Cu, 75 °C
- Temperature rating of wire insulation: min. 75 °C
- Torque value for terminal block on contact block: 1 Nm

Switching elements special devices

Step selector switch

General:	Cam-operated switch, M200 product series, M220 series, front mounting switch
Standards:	EN 60947, EN 60204, ANSI/UL 60947-1, ANSI/UL 60947-4-1A
Operating voltage U _o :	690 VAC
Rated impulse withstand voltage U _{imp} :	4 kV
Continuous current I _u / I _{th} / I _{the} :	20 A
Short circuit resistance max. back-up fuse:	20 A gL
Required short-circuit current:	10 kA _{eff}
Disconnecter characteristic according to EN 60947:	480 V/AC
Switching angles (depending on switch positions):	30°, 45°, 60°, 90°
Current paths max. possible:	24
Cable section:	
- Single/multi-wire:	1 to 2/5 mm ²
- Fine-wire or four-wire with wire-end ferrule:	1 to 2.5 mm ²
- American Wire Gauge:	AWG 12
Operating current I _o :	
- AC-21A:	20 A
- cUL 300 VAC:	20 A
- General Use 600 VAC:	-
Operating power at 50/60 Hz (3-pole):	
- AC-23A:	
* 220 to 240 V/AC:	4 kW
* 380 to 440 V/AC:	7.5 kW
* 500 V/AC:	7.5 kW
* 660 to 690 V/AC:	7.5 kW
- AC-3:	
* 220 to 240 V/AC:	3 kW
* 380-440 V/AC:	5.5 kW
* 500 V/AC:	5.5 kW
* 660 to 690 V/AC:	5.5 kW
- cUL:	
* 110 ... 120 VAC:	1 HP
* 208 VAC:	2 HP
* 220 ... 240 VAC:	2 HP
* 440 ... 480 VAC:	-
* 550 ... 600 VAC:	-
Mechanical lifetime: :	>1,000,000 operations
Climatic resistance:	
- damp heat, steady state, to:	DIN IEC 60068-2-78
- damp heat, cyclic, to:	DIN IEC 60068-2-30

Ambient temperature:

- open:	-25 °C ... +50 °C
- enclosed:	-25 °C ... +40 °C

Main switch	HHS16	HHS40	HHS63	HHS125
General:	Cam-operated switch, M200 product series, M220 series, Front mounting switch	Disconnect switch, H200 product series, H233 series, 3 pole on/off switch, Front mounting switch	Disconnect switch, B200 product series, B263 series, 3 pole on/off switch, Front mounting switch	Disconnect switch, H400 product series, H412 series, 3 pole on/off switch, Front mounting switch
Standards:	IEC 60947, IEC 60204, ANSI/UL 60947-1, ANSI/UL 60947-4-1	IEC 60947, IEC 60204, ANSI/UL 60947-1, ANSI/UL 60947-4-1	IEC 60947, IEC 60204, ANSI/UL 60947-1, ANSI/UL 60947-4-1	IEC 60947, IEC 60204, ANSI/UL 60947-1, ANSI/UL 60947-4-1
Operating voltage U_e :	690 VAC	690 VAC	690 VAC	690 VAC
Rated impulse withstand voltage U_{imp} :	4 kV	6 kV	6 kV	8 kV
Continuous current $I_u/I_{th}/I_{the}$:	20 A	40 A	63 A	125 A
Short circuit resistance max. back-up fuse:	20 A gL	40 A gL	63 A gL	125 A gL
Required short-circuit current:	10 kA _{eff}	15 kA _{eff}	15 kA _{eff}	25 kA _{eff}
Disconnecter characteristic according to EN 60947:	480 VAC	690 VAC	690 VAC	1000 VAC
Switching angle (depending on switch positions):	30°, 45°, 60°, 90°	90°	90°	90°
Current paths max. possible:	24	8	8	8
Cable section:				
- single-wire or multi-wire	1 ... 2.5 mm ²	1 ... 10 mm ²	6 ... 25 mm ²	4 ... 50 mm ²
- Fine-wire or four-wire with wire-end ferrule:	1 ... 2.5 mm ²	0.75 ... 6 mm ²	4 ... 16 mm ²	2.5 ... 35 mm ²
- American Wire Gauge:	AWG 12	AWG 8	AWG 4	AWG 1/0
Operating current I_e :				
- AC-21A:	20 A	40 A	63 A	125 A
- cUL 300 VAC:	20 A	40 A	63 A	100 A
- General Use 600 VAC:	-	40 A	63 A	100 A
Operating power at 50/60 Hz (3-pole)				
- AC-23A:				
* 220 ... 240 VAC:	4 kW	7.5 kW	15 kW	30 kW
* 380 ... 440 VAC:	7.5 kW	15 kW	22 kW	45 kW
* 500 VAC:	7.5 kW	15 kW	22 kW	45 kW
* 660 ... 690 VAC:	7.5 kW	15 kW	22 kW	37 kW
- AC-3:				
* 220 ... 240 VAC:	3 kW	5.5 kW	11 kW	30 kW
* 380 ... 440 VAC:	5.5 kW	11 kW	18.5 kW	37 kW
* 500 VAC:	5.5 kW	11 kW	18.5 kW	45 kW
* 660 ... 690 VAC:	5.5 kW	11 kW	18.5 kW	37 kW
- cUL:				
* 110 ... 120 VAC:	1 HP	3 HP	5 HP	15 HP
* 208 VAC:	2 HP	7.5 HP	-	-
* 220 ... 240 VAC:	2 HP	7.5 HP	10 HP	30 HP
* 440 ... 480 VAC:	-	15 HP	20 HP	60 HP
* 550 ... 600 VAC:	-	15 HP	10 HP	50 HP
Mechanical lifetime:	>1,000,000 operations	>100,000 operations	>100,000 operations	>100,000 operations
Climate resistance:				
- damp heat, steady state, to:	DIN IEC 60068-2-78	DIN IEC 60068-2-78	DIN IEC 60068-2-78	DIN IEC 60068-2-78
- damp heat, cyclic, to:	DIN IEC 60068-2-30	DIN IEC 60068-2-30	DIN IEC 60068-2-30	DIN IEC 60068-2-30
Ambient temperature:				
- open:	-25 °C ... +50 °C	-25 °C ... +50 °C	-25 °C ... +50 °C	-25 °C ... +50 °C
- enclosed:	-25 °C ... +40 °C	-25 °C ... +40 °C	-25 °C ... +40 °C	-25 °C ... +40 °C



The technical data for the main switch and step switch are duplicates of the technical data from SÄLZER. Please consult SÄLZER to ensure that the technical data is up to date.

3. Mounting

3.1 General mounting instructions for H program

1. The mounting recess must be designed as follows:

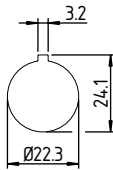

2. Alignment of the command device head in the installation recess and subsequent tightening of the central nut.

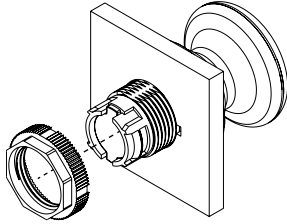

Only fit onto clean and grease-free surface!



Sealing elements to the control panel must be checked during installation to ensure that they are seated correctly and free of folds.

3. The contact elements are installed by snapping the contact elements onto the contact carrier.

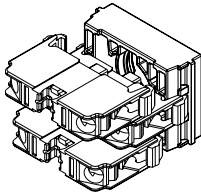

Lights must be installed in the centre position of the contact carrier.

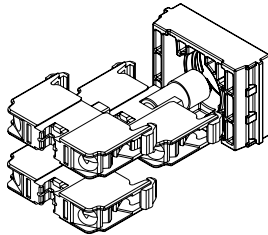

Double row contact elements

The contact elements in the second row are installed by snapping them onto the contact elements in the first row. No further contact element can be attached to the light element.

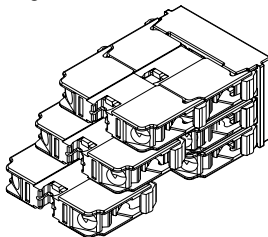

A maximum of 4 contact elements may be used on devices with latching. The fourth element must be mounted in the centre.

4. The contact carrier is snapped onto the command device head.

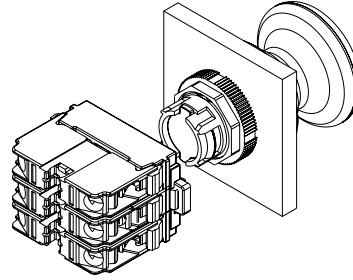

Main switches, step selector switches and potentiometer drives are snapped onto the device head. Main switch NHS125 is attached to the bolt. Refer to chapter 3.3.



Contact elements are not installed in the case of main switches and step selector switches.

3.2 Special mounting instructions for hygiene applications

For hygiene-related devices of the H series, which are mounted and can be used in the food-processing industry, water splash areas or non-food areas, the following additional requirements with regard to the installation are to be observed:

1. The devices must be arranged in such a way that cleaning with a cloth is possible in each position and when the switch is not actuated. It is therefore recommended to maintain a distance of at least 70 mm from mounting hole to mounting hole in order to ensure the normative distance of >20 mm.
2. If the device is connected from one or more sides to a housing wall, a radius of 100 mm from the centre of the mounting hole must be adhered to so that the device can be cleaned from all sides using a cloth and can be checked from all sides for damage.
3. Devices must be installed in such a way that liquids can drain from all surfaces. An incline of >3° is recommended on all device surfaces. Overhead installation of the devices is not recommended.



When positioning selector switches and potentiometer drives in particular, trough formation in grip recesses must be avoided.

4. Contact elements and lights must be installed protected behind the operating surface and are not intended to come into contact with foodstuffs. The devices should be installed in a closed installation space, such as a switch cabinet.



Please note the applicable standards and the design principles that apply to the machine or system in question.



Only fit onto clean, grease-free surface! When installing the device, ensure that the surface is flat and that there are no weld seams or bending radii of 100 mm around the device. Otherwise, the leak-tightness and hygiene properties of the device could be compromised. The surface must have a surface roughness of Ra 0.8 and, in the case of metallic surfaces, a levelness of 0.1.

3.3 Dimensions

All measurements in mm.

Indicator lights HML

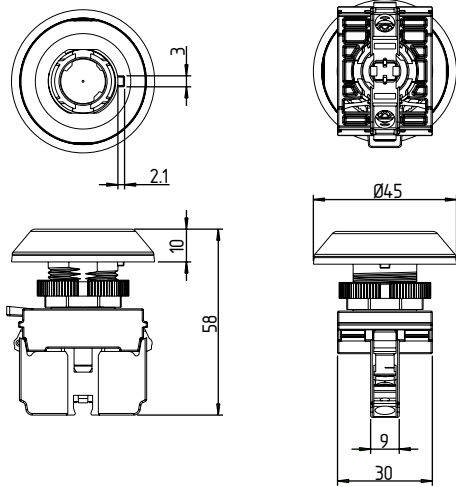

Push button / illuminated push button

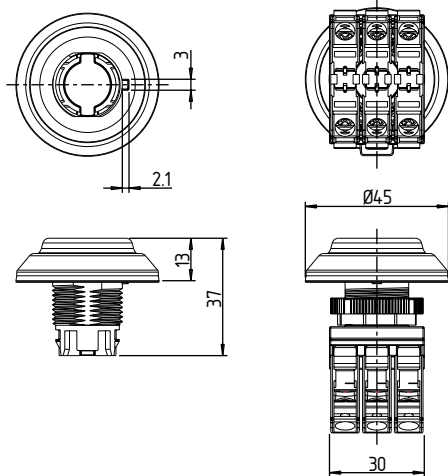

HDT

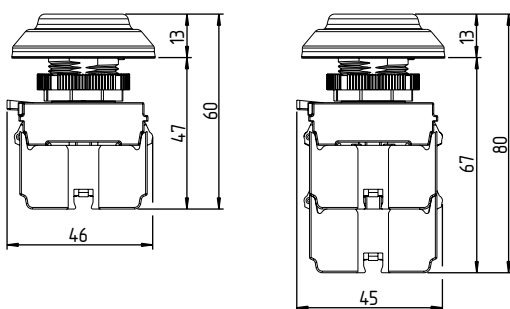

HDL

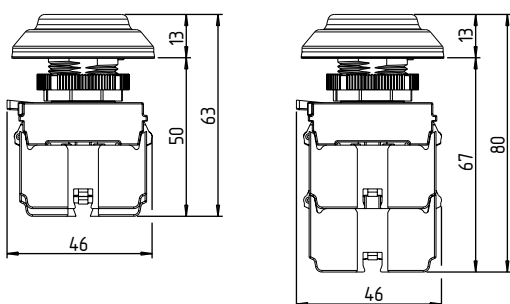

Small mushroom head impact button

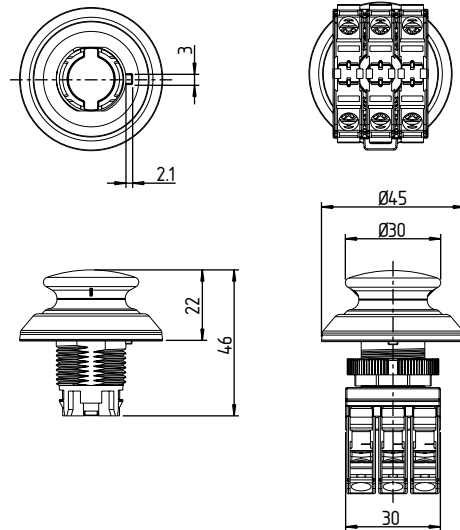

HDTP30

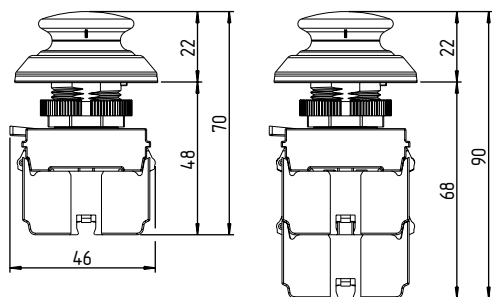

HDLP30

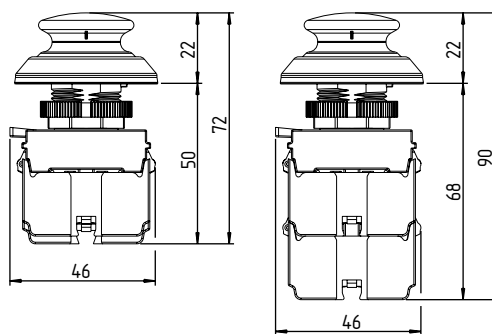

Large mushroom head impact button

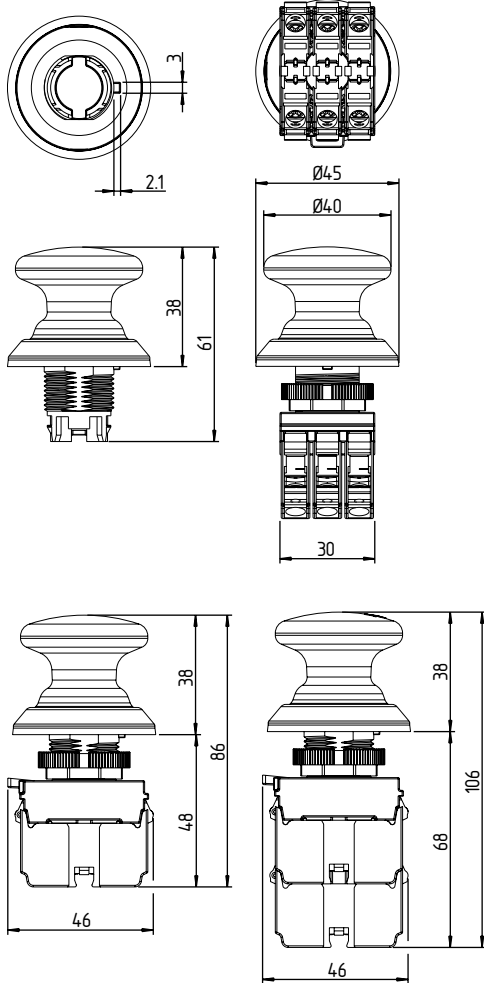

Selector switch / button

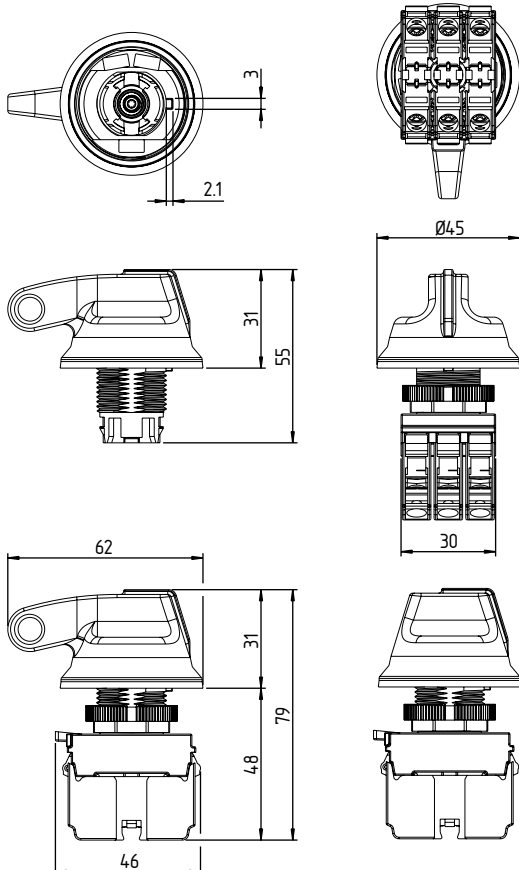

Step selector switch

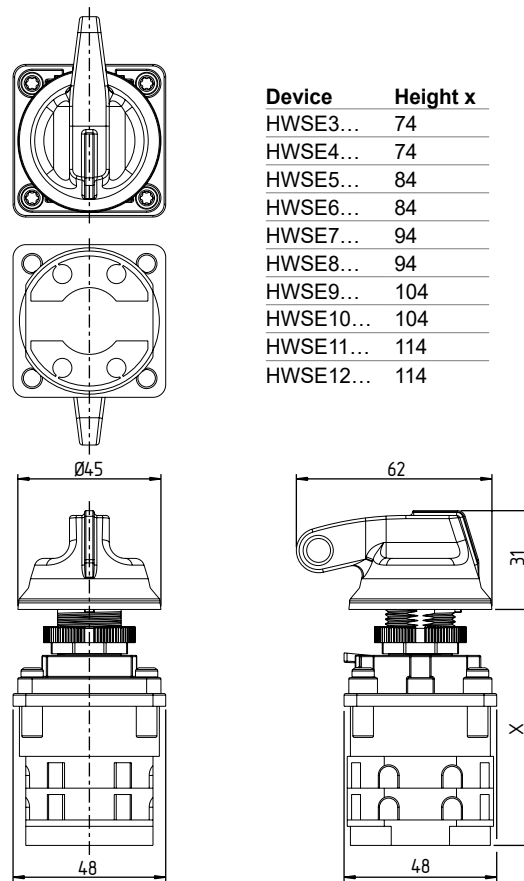

Device	Height x
HWSE3...	74
HWSE4...	74
HWSE5...	84
HWSE6...	84
HWSE7...	94
HWSE8...	94
HWSE9...	104
HWSE10...	104
HWSE11...	114
HWSE12...	114

Blanking plug

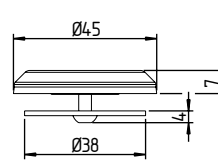

Contact carrier

SMF

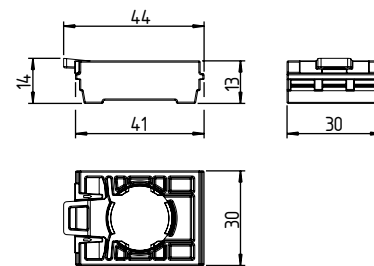

SMF-SG

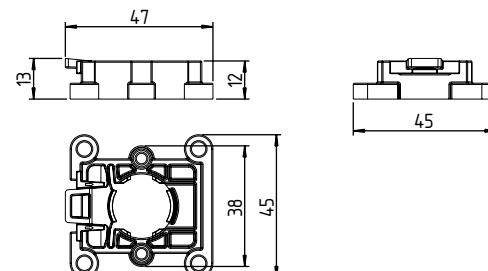

Potentiometer drive

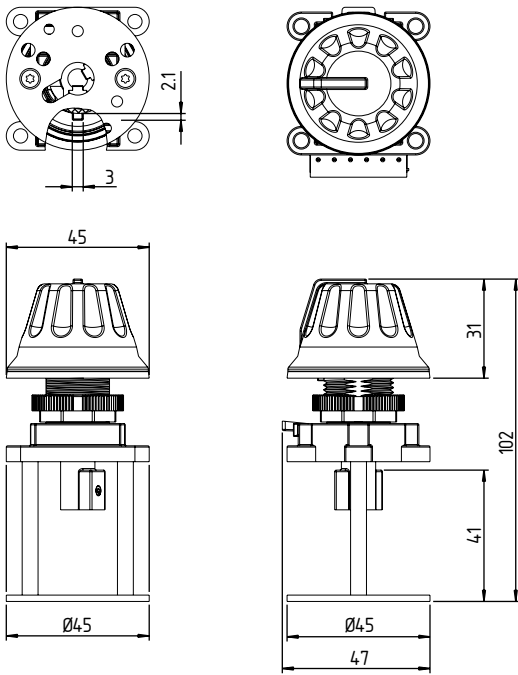

Main switch HHS16

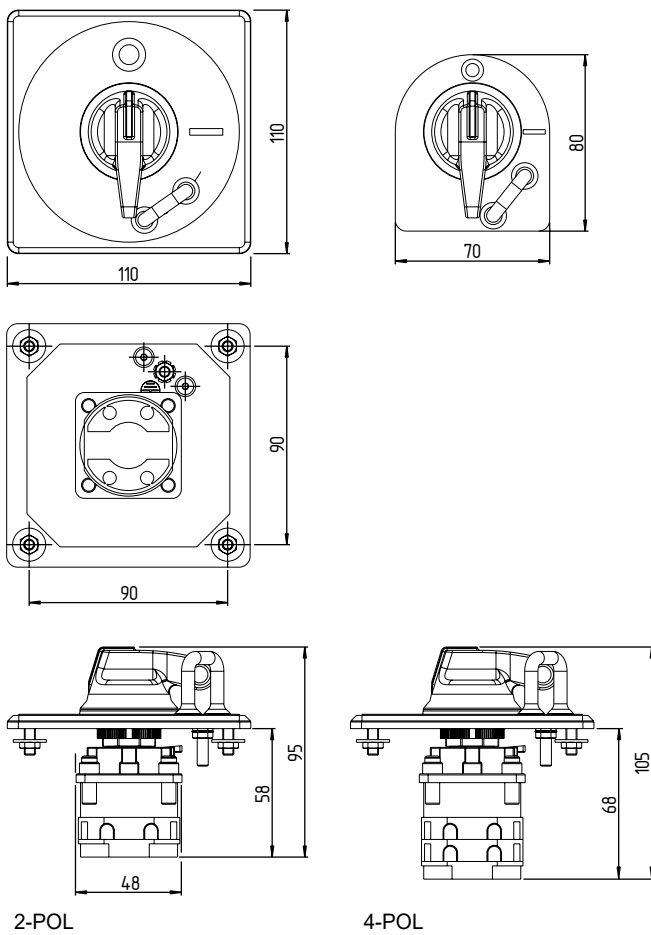

2-POL

4-POL

Main switch HHS40

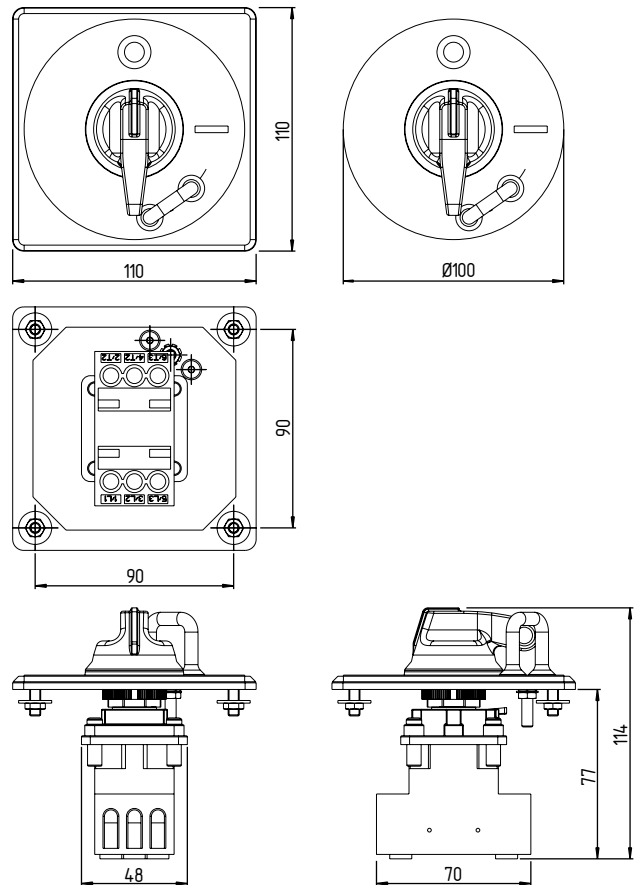

Main switch HHS63

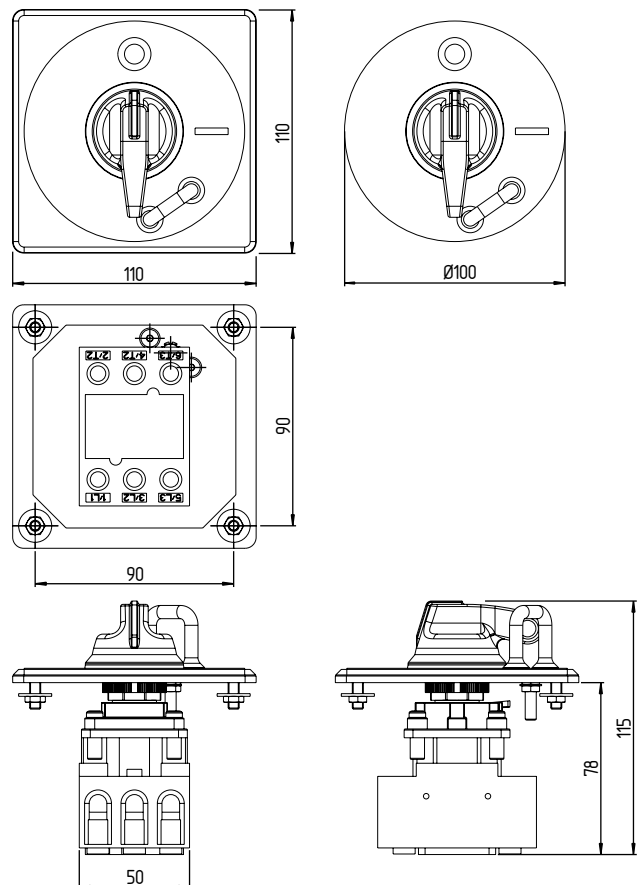

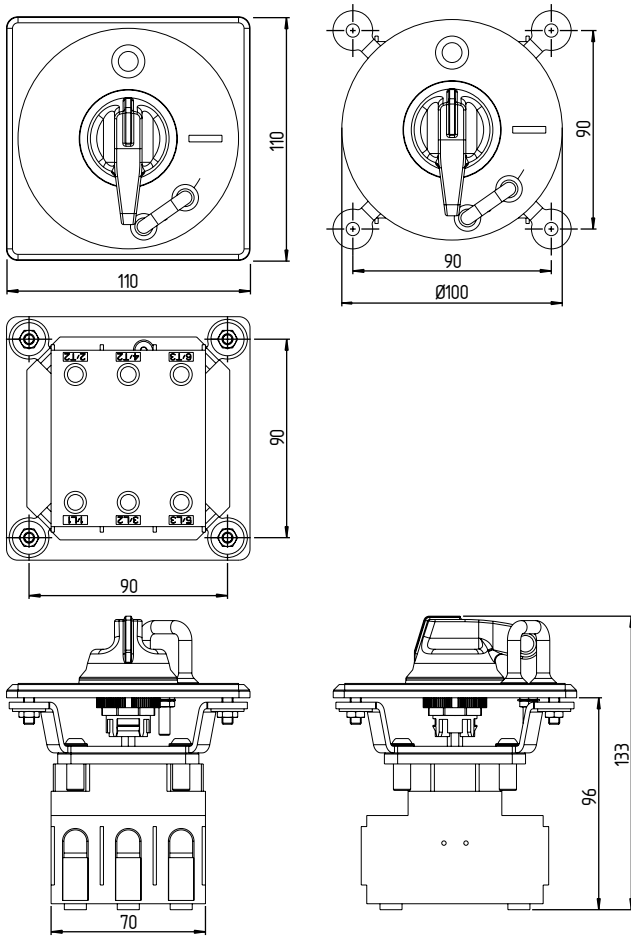

Main switch HHS125



4. Electrical connection

4.1 General information for electrical connection

-  The electrical connection may only be carried out by authorised personnel in a de-energised condition.
-  The front panel/operating panel must have an appropriate earth connection.
-  After wiring, the contact elements must be cleaned (i.e. remove excess cables etc.).



Settle length x of the conductor CLP contact system: 7 mm



Settle length x of the conductor step switch and main switch:

The settle length of the conductor step switch and main switch can be found in the technical data provided by SÄLZER.

5. Set-up and maintenance





-  The cleaning process and the cleaning/disinfectant agent must be appropriate to the foodstuffs being processed. The cleaning process, such as dry or wet cleaning, and the appropriate disinfection procedure must be designed in accordance with DIN 10516. This may mean that certain actions deviate from the stated recommendations.
-  All important criteria for the cleaning and disinfection processes must be laid down in a cleaning and disinfection plan that is specific to the company (where, what, when, who, with what, how). A check of the effectiveness of cleaning and disinfection must also be carried out.

5.1 Functional testing

- The function of the component must be tested. The following conditions must be checked and met:
1. Correct fixing of the fitted component
 2. Check the integrity of the connections
 3. Check the command device for damage
 4. Check the correct seating of the gaskets
 5. Pre-cleaning see chapter 5.3

5.2 Maintenance

- A regular visual inspection and functional test, including the following steps, is recommended:
1. Check the correct fixing of the command device and the contact element
 2. Remove particles of dust and soiling
 3. Check the integrity of the connections
 4. Check the correct seating of the gaskets
 5. Cleaning see chapter 5.3

-  The contact carrier must be replaced after disassembly.
-  Contacts must not be removed from the contact carrier in their installed state.
-  Damaged or defective components must be replaced immediately. There is an immediate hygiene risk relevant to food safety.
-  Cleaning must be carried out before commissioning and after maintenance and repair work.
-  In the event of use with permanent UV influence, weekly checks of the sealing elements must be carried out.

5.3 Cleaning and disinfection

5.3.1 General

- The devices must be cleaned thoroughly after installation and before initial commissioning.
- Cleaning and, if applicable, disinfection intervals must be adapted according to the existing cleanliness requirements and the cleaning/disinfection plan. Daily cleaning is recommended. Cleaning must also take place no later than when visible soiling is observed. If disinfection is required, this must always take place after cleaning.
- The selected cleaning and, if applicable, disinfection process and agents must not damage or negatively affect the surfaces and properties of the materials, especially gaskets.
- Use only clean utensils (e.g. soft cloths, soft uncoated sponges, brushes with soft bristles) that cannot damage the surface. Check the cleanliness of the cleaning utensils before use.
- Impermissible and unsuitable cleaning agents and utensils can damage the devices and gaskets and may not be used.
- In the event of wet cleaning and disinfection, the resistance of the cleaning agent, cleaning temperature and selection of the disinfectant in relation to the materials must be clarified with the manufacturer of the disinfectant.
- Cleaning agents must be fully rinsed away afterwards with water of drinking water quality without leaving any residue.

- The devices should be checked before and after cleaning for damage. Particular attention must be paid to the sealing elements.
- When cleaning rotating devices, particular care must be exercised to ensure that soiling is removed from grip recesses and lock slots.



If soiling is still visible after cleaning, the cleaning process must be repeated.



Cleaning agents must be fully rinsed away afterwards with water of drinking water quality without leaving any residue. A mixture of cleaning agents on the device must be avoided as this can cause damage. The information provided by cleaning agent manufacturers on acting times, mixing ratios, etc. must be observed. Applying cleaning agents overnight or over similarly long periods of time is not permitted.

Not permitted for cleaning:

- Cleaning agents containing abrasive particles.
- Pointed and hard objects, such as brushes with hard bristles, steel brushes, steel wool, steel wool sponges, sponges with an abrasive coating.
- Abrasive methods, such as lasers, ultrasound, dry ice, compressed-air.
- Methods involving vapours, such as nitrogen, steam cleaning.

5.3.2 Dry cleaning

We recommend that dry soiling be removed dry with the cleaning utensils referred to in section 5.3.1 until the desired level of cleanliness is achieved. Hard particles of dirt (e.g. sand) can damage the smooth surfaces of devices when cleaning manually. Work with caution so that surfaces are not damaged and soiling cannot penetrate the area under gaskets.



Dry cleaning can take place before wet cleaning.

5.3.3 Wet cleaning

Procedure:

1. Wash off the devices with water to remove coarse soiling.
2. Lather all surfaces.

We recommend using an alkaline cleaner according to the tested cleaning agents referred to in section 5.3.5. The information provided by cleaning agent manufacturers on acting times, mixing ratios, etc. must be observed.

3. Wash off foam with water. Light water pressure of 3 to 5 bar may be applied. When using a water jet, a distance of >40 cm is recommended. The jet should be angled from above at a maximum angle of 45 to 60°. All surfaces must be reached. Spray shadows must be avoided, as these lead to an inadequate cleaning outcome.

If soiling is still visible after cleaning, the cleaning process must be repeated.



It must be ensured that the gaskets are not damaged or destroyed by direct jets at high pressure, and that soiling does not penetrate under the gaskets. In the event that heavy soiling necessitates manual cleaning, also observe the notes in sections 5.3.1 and 5.3.2.



Cleaning with a scouring agent or cleaning agents containing abrasives is not permitted. Removing coarse soiling with steel wool, steel wool sponges or wire brushes is not permitted.



When cleaning at high pressure (80 bar), a distance of >20 cm must be maintained. High-pressure cleaning is not recommended for hygiene reasons. No point must be cleaned for more than 5 s at a time.

5.3.4 Disinfection

The notes on use, acting time and other measures stipulated by the disinfectant manufacturer must be observed for disinfection.

5.3.5 Recommended cleaning agents

Certified cleaning and care products along with their main ingredients can be gleaned from the list at the end of the chapter. These cleaning agents have been tested in a standardised ECOLAB procedure or in an alternative storage test. A change in colour is no indication of a quality defect on the device.

If other cleaning and care products are used with the same or similar ingredients, no liability will be accepted for damage to the device. Responsibility for this lies solely with the operator of the machine or plant system.

Product	Description	Concentration	PH value (1%)	Main ingredients
Topactive 500	Foam cleaner, acidic	5%	1.7 - 2.1	Phosphoric acid, surfactant
Aciplusfoam VF59	Foam cleaner, acidic	5%	2	Phosphoric acid, surfactant, nitric acid
P3 – Topactive DES	Foam cleaner, acidic	3%	3.2 - 3.6	Hydrogen peroxide, acetic acid, Peracetic acid, surfactants
CD water	Completely desalinated water	100%	5 - 6	Demineralsised water
P3 – Alcodes	Acetic acid, alkylamine oxide	100%	6.8 - 7.8	Ethanol
P3 – Topax 990	Disinfectant, neutral	3%	7.4 - 8.4	Acetic acid, alkylamine oxide
Tego 2000 VT25	Disinfectant, neutral	1%	8	Amphotenside
Divodes FG VT29	Disinfectant, neutral	100%	8.8	Alcohol
P3 – Topax 66	Foam cleaner, alkaline	3%	11.6 - 12	Surfactants, phosphonates, sodium hypochlorite
Oxofoam VF5	Foam cleaner, highly alkaline	5%	12.7	Potash, surfactant, sodium hypochlorite
Powerfoam VF4	Foam cleaner, highly alkaline	5%	12.8	Caustic soda, EDTA, surfactant
Topactive 200	Foam cleaner, alkaline	5%	12.8 - 13.2	Ethanol, sodium hydroxide, potassium hydroxide, surfactants

6. Disassembly and disposal

6.1 Disassembly devices with SMF contact carrier



The devices must be disassembled in a de-energised condition only.

1. Disassembly of the contact carrier is carried out with the aid of a size 2 slot screwdriver.

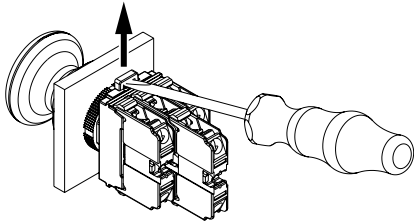

2. Disassembly of the CLP contact elements from the contact carrier is carried out with the aid of a slot screwdriver with the recommended width of 5.5 mm.

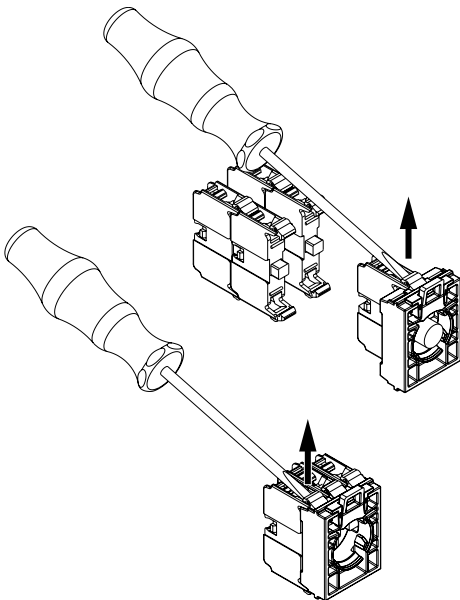

The contact carrier must be replaced after disassembly.



To prevent damage to lights, the use of a size 5 internal hex key is recommended to lever the release tab on the opposite side (see section 6.2).

6.2 Disassembly devices with SMF-SG-contact carrier

Disassembly of the SMF-SG contact carrier is carried out with the aid of a size 2 slot screwdriver and size 5 internal hex key. Release the release tab with the slot screwdriver. Using the internal hex key at the same time, lever the device straight downwards.

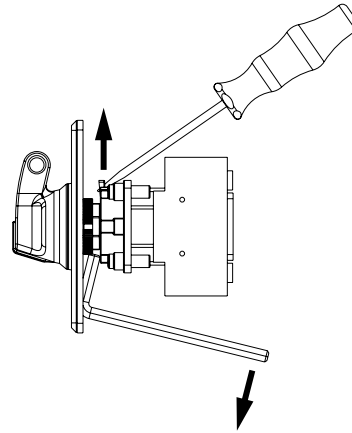

The contact carrier must be replaced after disassembly.

6.3 Disposal

The switchgear must be disposed of in an appropriate manner in accordance with the national prescriptions and legislations.

7. EU Declaration of conformity

EU Declaration of conformity



Original
K.A. Schmersal GmbH & Co. KG
Möddinghofe 30
42279 Wuppertal
Germany
Internet: www.schmersal.com

We hereby certify that the hereafter described components both in their basic design and construction conform to the applicable European Directives.

Name of the component: H program

Type: see ordering code

Description of the component: Command and signalling devices optionally as indicator lights, push buttons, illuminated push buttons, mushroom head impact buttons and switches, selector switches and selector buttons in conjunction with contact element and light elements CLP as well as potentiometer drives, step selector switches and main switches.

Relevant Directives:
Low Voltage Directive 2014/35/EU
EMC-Directive 2014/30/EU
RoHS-Directive 2011/65/EU

Applied standards: EN 60947-5-1:2017 + AC:2020

Person authorised for the compilation of the technical documentation: Oliver Wacker
Möddinghofe 30
42279 Wuppertal

Place and date of issue: Wuppertal, June 18, 2024

Authorised signature
Philip Schmersal
Managing Director

H-Programm-A-EN



The currently valid declaration of conformity can be downloaded from the internet at products.schmersal.com.



K.A. Schmersal GmbH & Co. KG
Möddinghofe 30, 42279 Wuppertal
Germany
Phone: +49 202 6474-0
Telefax: +49 202 6474-100
E-Mail: info@schmersal.com
Internet: www.schmersal.com