



**EN** Operating instructions. . . . .pages 1 to 8  
Original

**Content**

**1 About this document**

1.1 Function . . . . . 1

1.2 Target group: authorised qualified personnel. . . . . 1

1.3 Explanation of the symbols used . . . . . 1

1.4 Appropriate use . . . . . 1

1.5 General safety instructions . . . . . 1

1.6 Warning about misuse . . . . . 1

1.7 Exclusion of liability . . . . . 2

**2 Product description**

2.1 Ordering code . . . . . 2

2.2 Special versions. . . . . 2

2.3 Determination and use for functional safety in accordance with the Machinery Directive. . . . . 2

2.4 Determination and use for explosion protection. . . . . 2

2.5 Technical data . . . . . 2

2.6 Safety classification of the interlocking function. . . . . 3

2.7 Safety classification of the interlock function . . . . . 3

**3 Mounting**

3.1 General mounting instructions . . . . . 3

3.2 Dimensions . . . . . 4

3.3 Mounting of individually coded actuators. . . . . 5

**4 Rear side Electrical connection**

4.1 General information for electrical connection. . . . . 5

4.2 Contact Options . . . . . 6

**5 Set-up and maintenance**

5.1 Functional testing. . . . . 7

5.2 Maintenance . . . . . 7

**6 Disassembly and disposal**

6.1 Disassembly. . . . . 7

6.2 Disposal . . . . . 7

**7 EU Declaration of conformity**

**1. About this document**

**1.1 Function**

This operating instructions manual provides all the information you need for the mounting, set-up and commissioning to ensure the safe operation and disassembly of the safety switchgear. The operating instructions must be available in a legible condition and a complete version in the vicinity of the device.

**1.2 Target group: authorised qualified personnel**

All operations described in this operating instructions manual must be carried out by trained specialist personnel, authorised by the plant operator only.

Please make sure that you have read and understood these operating instructions and that you know all applicable legislations regarding occupational safety and accident prevention prior to installation and putting the component into operation.

The machine builder must carefully select the harmonised standards to be complied with as well as other technical specifications for the selection, mounting and integration of the components.

**1.3 Explanation of the symbols used**



**Information, hint, note:**

This symbol indicates useful additional information.



**Caution:** Failure to comply with this warning notice could lead to failures or malfunctions.

**Warning:** Failure to comply with this warning notice could lead to physical injury and/or damage to the machine.

**1.4 Appropriate use**

The Schmersal range of products is not intended for private consumers.

The products described in these operating instructions are developed to execute safety-related functions as part of an entire plant or machine. It is the responsibility of the manufacturer of a machine or plant to ensure the correct functionality of the entire machine or plant.

The safety switchgear must be exclusively used in accordance with the versions listed below or for the applications authorised by the manufacturer. Detailed information regarding the range of applications can be found in the chapter "Product description".

**1.5 General safety instructions**

The user must observe the safety instructions in this operating instructions manual, the country specific installation standards as well as all prevailing safety regulations and accident prevention rules.



Further technical information can be found in the Schmersal catalogues or in the online catalogue on the Internet: [products.schmersal.com](http://products.schmersal.com).

The information contained in this operating instructions manual is provided without liability and is subject to technical modifications. There are no residual risks, provided that the safety instructions as well as the instructions regarding mounting, commissioning, operation and maintenance are observed.

**1.6 Warning about misuse**



In case of improper use or manipulation of the safety switchgear, personal hazards or damages to machinery or plant components cannot be excluded. The relevant requirements of the standard EN ISO 14119 must be observed.

### 1.7 Exclusion of liability

We shall accept no liability for damages and malfunctions resulting from defective mounting or failure to comply with this operating instructions manual. The manufacturer shall accept no liability for damages resulting from the use of unauthorised spare parts or accessories.

For safety reasons, invasive work on the device as well as arbitrary repairs, conversions and modifications to the device are strictly forbidden, the manufacturer shall accept no liability for damages resulting from such invasive work, arbitrary repairs, conversions and/or modifications to the device.

## 2. Product description

### 2.1 Ordering code

This operating instructions manual applies to the following types:

#### EX-AZM170-①Z②③④-⑤-⑥-⑦-⑧-3GD

No.	Option	Description
①	11 02	1 NO / 1 NC 2 NC
②	R	latching force 5 N latching force 30 N
③	K I	standard coded (Actuator not included in delivery) individually coded (incl. actuator, see ⑧)
④	A	power to unlock power to lock
⑤	A1	silver-plated contacts gold-plated contacts 0.3 µm
⑥	2680 P	without connecting cable with connecting cable, length 10 m with protective enclosure,
⑦	R/P	mounting parallel to safety guard with protective enclosure, mounting right-angled to safety guard
⑧	B1 B5 B6L B6R	straight actuator B1 angled actuator B5 flexible actuator B6L flexible actuator B6R

#### EX-AZM170-①Z②③④-⑤-⑥-3GD

No.	Option	Description
①	01/02	1 NC / 2 NO
②	R	latching force 30 N
③	K	standard coded (Actuator not included in delivery)
④	2718-1 A-2718	power to unlock power to lock
⑤	10 m	with connecting cable, length 10 m
⑥	P R/P	with protective enclosure, mounting parallel to safety guard with protective enclosure, mounting right-angled to safety guard



Only if the information described in these operating instructions are realised correctly can the safety function and therefore the compliance with the Machinery/Explosion Protection Directive be maintained.

### 2.2 Special versions

For special versions, which are not listed in the order code below 2.1, these specifications apply accordingly, provided that they correspond to the standard version.

### 2.3 Determination and use for functional safety in accordance with the Machinery Directive.

The solenoid interlock has been designed to prevent in conjunction with the control part of a machine, movable safety guards from being opened before hazardous conditions have been eliminated.



Interlocks with power to lock principle may only be used in special cases after a thorough evaluation of the accident risk, since the safety guard can be opened immediately on failure of the power supply or upon activation of the main switch.



The user must evaluate and design the safety chain in accordance with the relevant standards and the required safety level.



The entire concept of the control system, in which the safety component is integrated, must be validated to the relevant standards.

The EX-AZM170 I solenoid interlocks with individual coding offer a higher protection against tampering.



The safety switchgears are classified according to EN ISO 14119 as type 2 interlocking devices. Designs with individual coding are classified as highly coded.

### Manual release

A manual release is available as a mounting tool and in the event of a power failure in case the power to unlock principle is used. If the triangular key is turned 180°, the locking bolt is pulled into the unlocking position. Please ensure that jamming by external influence on the actuator is avoided. The normal locking function is only restored after the triangular key has been returned to its original position. After being put into operation, the manual release must be secured by installing the sealing plug, which is included in delivery.

### Manual release

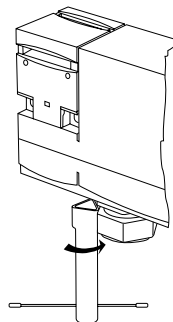

Triangular key TK-M5 (101100887) available as accessory.

### 2.4 Determination and use for explosion protection

The components can be used in potentially explosive atmospheres of Zone 2 and 22 equipment category 3GD. The installation and maintenance requirements to the standard series 60079 must be met.

### Conditions for safe operation

The specific ambient temperature range must be observed. The user must provide for a protection against the permanent influence of UV rays.

### 2.5 Technical data

Marking in accordance with the ATEX Directive: Ⓢ II 3GD

Marking in accordance with standards: Ex nC IIB T5 Gc,

Ex tc IIIC T80°C Dc

Applied standards: EN 60947-5-1, EN ISO 14119,

EN IEC 60079-0, EN IEC 60079-15, EN 60079-31, ISO 80079-36

Enclosure: glass-fibre reinforced thermoplastic, self-extinguishing

Protective enclosure: metal, coated

Actuator and locking bolt: stainless steel 1.4301

Holding force  $F_{max}$ : 1,300 N

Holding force  $F_{Zh}$ : 1,000 N

Latching force: 5 N

- Ordering suffix R: 30 N

Coding level according to EN ISO 14119:

- Standard coding version:	low
- Individual coding version:	high
Degree of protection:	IP67
Contact material:	silver,

version -A1 gold-plated  
Contact types: change-over contact with double break, type Zb or 2 NC contacts, with galvanically separated contact bridges

Switching system:  $\ominus$  acc. EN 60947-5-1 slow action, NC contact with positive break

Connection: cut clamp terminals

Cable section: 0.75 ... 1.0 mm<sup>2</sup>, flexible

Cable entry: M16

Cable glands:  $\otimes$  II 2GD

Cable cross-section:  $\varnothing$  6.5 ... 12 mm

Tightening torque:

- Cable gland: 4.5 Nm

- Cover screws (cylindrical screw M3 x 20): 0.4 ... 0.5 Nm

Ambient temperature: -15 °C ... +45 °C

Positive break travel (unlocked): 11 mm

Positive break force (unlocked): 6 N for each NC contact fitted

Actuating speed: max. 1 m/s

Actuating frequency: max. 1,000 operations/h

Mechanical life: max. 1 million operations

Max. impact energy: 7 J

**Electrical data:**

Utilisation category: AC-15 / DC-13

Rated operating current/voltage  $I_e/U_e$ : 2 A / 24 VAC

Rated impulse withstand voltage  $U_{imp}$ : 4 kV

Rated insulation voltage  $U_i$ : 250 V

Thermal test current  $I_{the}$ : 2 A

Max. fuse rating: 2 A gG D-fuse

Required rated short-circuit current: 1,000 A

Rated control voltage  $U_s$ : 24 VDC

24 VAC / 50/60 Hz

**Electrical data – Magnet control:**

Magnet switch-on time: 100%

Power consumption: max. 10 W

Accepted test pulse duration on input signal:  $\leq$  5.0 ms

- With test pulse interval of:  $\geq$  50 ms

**2.6 Safety classification of the interlocking function**

Standards: EN ISO 13849-1

Envisaged structure:

- Basically: applicable up to Cat. 1 / PL c

- With 2-channel usage and

fault exclusion mechanism\*: applicable up to Cat. 3 / PL d

with suitable logic unit

$B_{10D}$  NC contact: 2,000,000

$B_{10D}$  NO contact at 10% ohmic contact load: 1,000,000

Service life: 20 years

\* If a fault exclusion to the 1-channel mechanics is authorised.

$$MTTF_D = \frac{B_{10D}}{0,1 \times n_{op}} \quad n_{op} = \frac{d_{op} \times h_{op} \times 3600 \text{ s/h}}{t_{cycle}}$$

(Determined values can vary depending on the application-specific parameters  $h_{op}$ ,  $d_{op}$  and  $t_{cycle}$  as well as the load.)

If multiple safety components are wired in series, the Performance Level to EN ISO 13849-1 will be reduced due to the restricted error detection under certain circumstances.

**2.7 Safety classification of the interlock function**

If the device is used as an interlock for personal safety, a safety classification of the guard locking function is required.

When classifying the interlock function, a distinction must be made between monitoring of the interlock function (locking function) and controlling the unlocking function.

The following safety classification of the unlocking function is based on the application of the principle of safety energy disconnection for the solenoid supply.



The safety classification of the unlocking function is only valid for devices with monitored guard locking function and in the power to unlock version (see ordering code).

A fault exclusion for the guard locking function can be assumed by an external safety energy disconnection.

In this case, the guard locking function does not have an effect on the failure probability of the unlock function.

The safety level of the unlock function is determined exclusively by the external safety power shutdown.

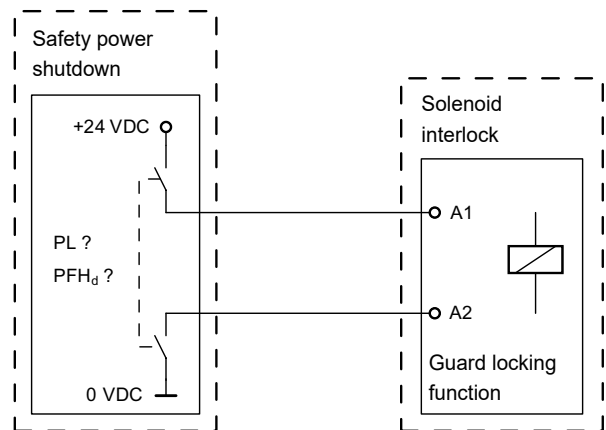

Fault exclusion with regard to wiring routing must be observed.



If for a certain application the power to unlock version of a solenoid interlock cannot be used, for this exception an interlock with power to lock can be used if additional safety measure need to be realised that have an equivalent safety level.

**3. Mounting**

**3.1 General mounting instructions**



Fitting is only authorised in a de-energised condition

Two mounting holes are provided for fixing the enclosure. The solenoid interlock is double insulated. The use of an earth wire is not authorised. The solenoid interlock must not be used as an end stop. Any mounting position. The mounting position must be chosen so as to avoid the penetration of dirt in the used holes. The unused opening must be sealed by means of slot sealing plugs.



In order to provide for an increased mechanical protection, the solenoid interlock must be fitted with the additional -CL/-CR protective enclosure (included in delivery).



Please observe the recommendations regarding maximum impact energy, actuating speed and tightening torque in the technical data.



Please observe the remarks of the standards EN ISO 12100, EN ISO 14119 and EN ISO 14120.



The actuator must be permanently fitted to the safety guards and protected against displacement by suitable measures (tamperproof screws, gluing, drilling of the screw heads).

### 3.2 Dimensions

All measurements in mm.

#### Solenoïd interlock EX-AZM170

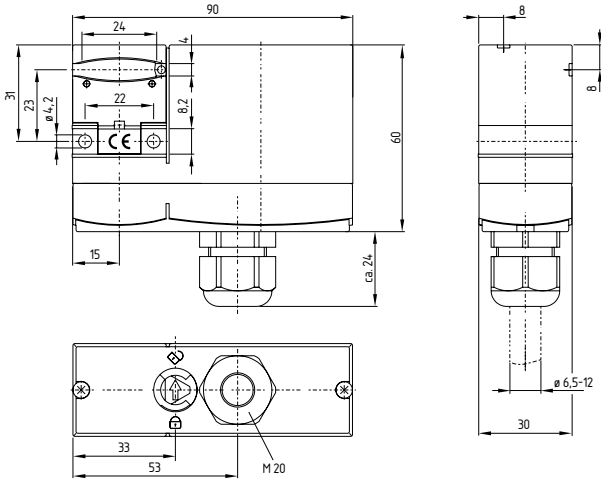

#### Mounting plate for protective enclosure -P or -R/P

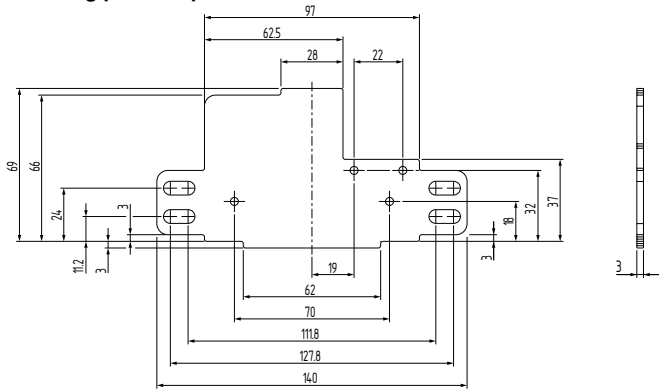

#### Protective enclosure EX-AZM170-P

(Mounting parallel to safety guard)

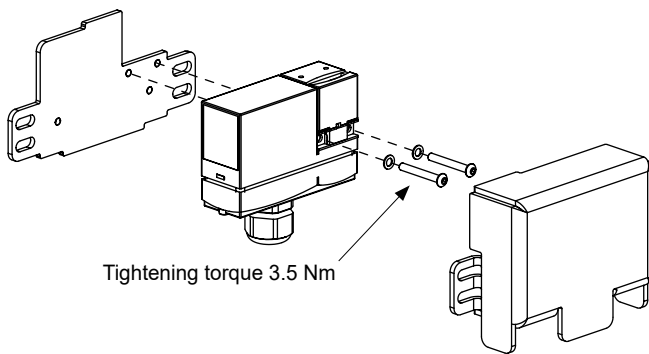

#### Included in delivery:

- AZM170
- Protective enclosure
- Mounting plate
- 2x screws
- 2x washers

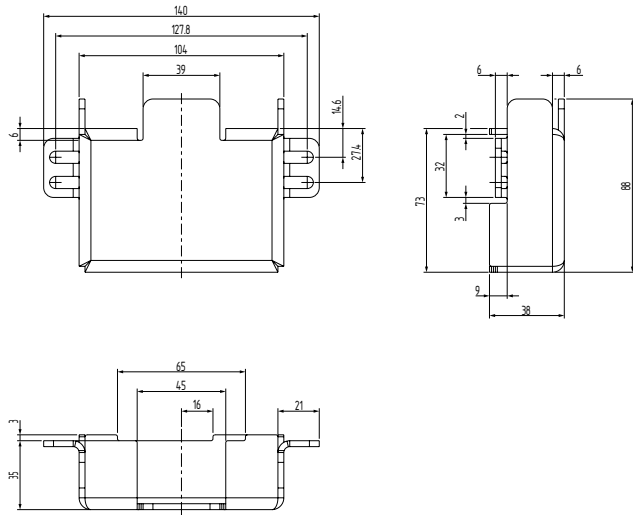

#### Protective enclosure EX-AZM170-R/P

(Mounting right-angled to safety guard)

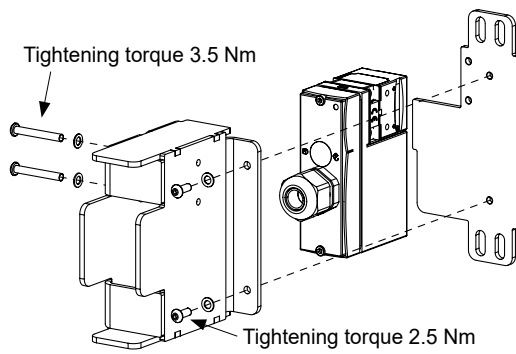

#### Included in delivery:

- AZM170
- Protective enclosure
- Mounting plate
- 4x screws
- 4x washers

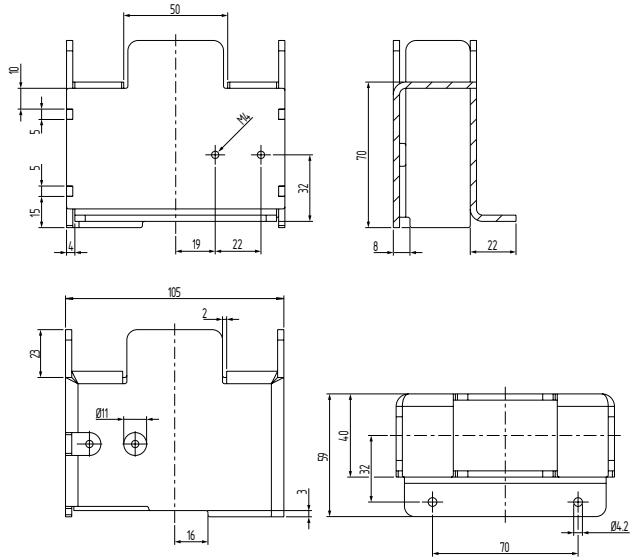

**3.3 Mounting of individually coded actuators**

(included in the scope of delivery when ordering an individually coded solenoid interlock)



In the as-delivery condition, the actuator of the individually coded solenoid interlock is inserted in the upper actuator inlet. On delivery, the actuator is in inserted condition. For power-to-unlock components, the actuator must be released by means of the manual release. If the triangular key is turned 180°, the locking bolt is pulled into the unlocking position. The normal locking function is only restored after the triangular key has been returned to its original position.



The marks on the used actuator opening of the solenoid interlock and on the actuator must be opposite.

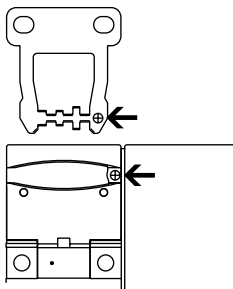

Please observe that, when fixing the switch e.g. by means of rivetting or welding, the insertion depth of the actuator is not modified. Different actuator forms are available. The actuators B1 and B5 are preferably used for sliding and removable safety guards. For hinged guards, the B6R and B6L actuators.

Straight actuator B1

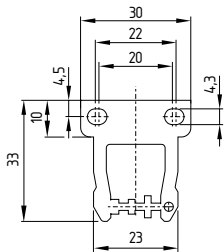

Angled actuator B5

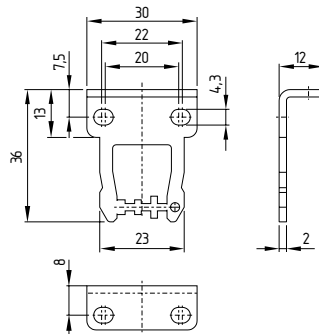

Flexible actuator B6L

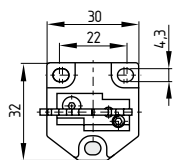

Flexible actuator B6R

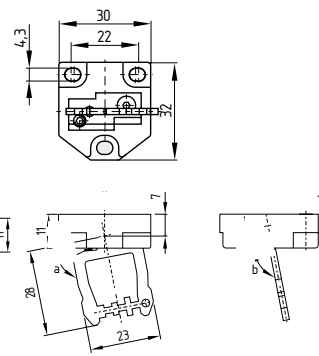

**Setting screw**

The B6L or B6R actuators are set to the smallest radius in factory. To increase the radius, the setting screws a + b must be turned by means of a hexagonal key A/F 2.0 mm.

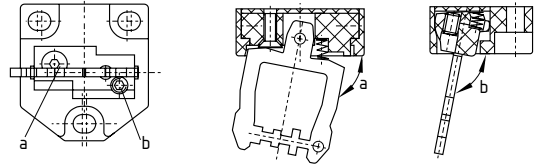

Strength of the actuator screws 5.6.

When the switch is fitted on a hinged safety guard, please ensure that the point of rotation is located within the range of the upper surface of the safety switch, in which the actuator hook is inserted (refer to table).

Actuating radii				
	$R_{min}$ [mm]	d [mm]	$R_{min}$ [mm]	d [mm]
<b>B6L</b>	50	11	50	11
<b>B6R</b>	50	11	50	11

**Key**

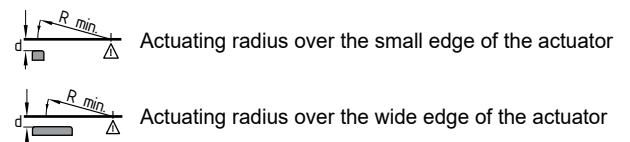

The axis of the hinge must be d mm above and in a parallel plane to the top surface of the safety switch. The basis setting provides a minimum radius of Rmin.

**4. Rear side Electrical connection**

**4.1 General information for electrical connection**



The electrical connection may only be carried out by authorised personnel in a de-energised condition.

The contact labelling can be found in the wiring compartment of the switch.



Only use Ex cable glands with integrated or associated seals which are authorised for the corresponding field of application (included in delivery). Cable glands are only authorised for permanent cables. The constructor must provide for the necessary strain relief.

## IDC method of termination

The IDC method of termination (cut clamp technology) enables connecting flexible wires with cable section 0.75 ... 1 mm<sup>2</sup> without using conductor ferrules. To this effect, strip the wire according to the drawing (refer to the wiring example) and insert it into the cable gland, close the cable gland, push the conductors in the groove of the cover (refer to wiring example) and screw the cover back. Observe that the individual conductors remain in position to avoid jamming.

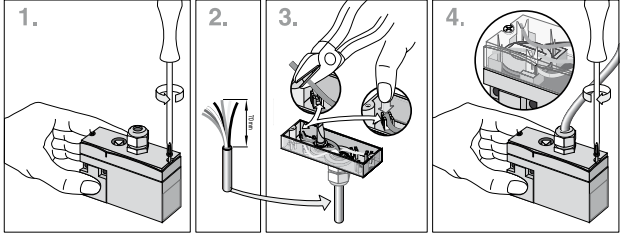

## 4.2 Contact Options

The contact labelling can be found in the wiring compartment of the switch.

Contacts shown in de-energised condition and with the actuator inserted.



If the risk analysis indicates the use of a monitored interlock they are to be connected in the safety circuit with the contacts indicated with the symbol

### Power to unlock

**EX-AZM170-11ZRK-3GD**  
**EX-AZM170-11ZRI-3GD**

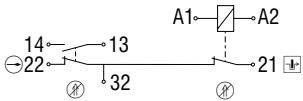

### Power to lock

**EX-AZM170-11ZRKA-3GD**  
**EX-AZM170-11ZRKA-3GD**

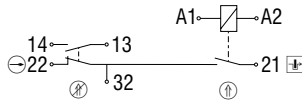

**EX-AZM170-02ZRK-3GD**  
**EX-AZM170-02ZRI-3GD**

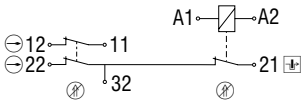

**EX-AZM170-02ZRKA-3GD**  
**EX-AZM170-02ZRKA-3GD**

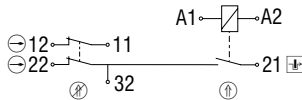

### Power to unlock

**EX-AZM170-11ZRK-2680-3GD**  
**EX-AZM170-11ZRI-2680-3GD**

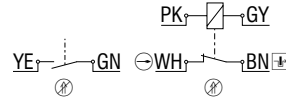

### Power to lock

**EX-AZM170-11ZRKA-2680-3GD**  
**EX-AZM170-11ZRKA-2680-3GD**

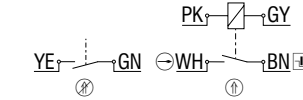

**EX-AZM170-02ZRK-2680-3GD**  
**EX-AZM170-02ZRI-2680-3GD**

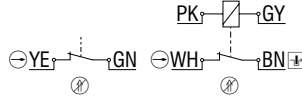

**EX-AZM170-02ZRKA-2680-3GD**  
**EX-AZM170-02ZRKA-2680-3GD**

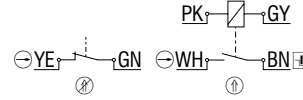

### Assignment of the connection cable

GN (green)

YE (yellow)

PK (pink)

GY (grey)

BN (brown)

WH (white)

### Power to unlock

**EX-AZM170-01/02ZRK-2718-1-10M-3GD**

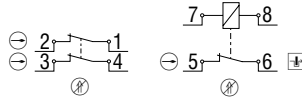

### Power to lock

**EX-AZM170-01/02ZRKA-2718-1-10M-3GD**

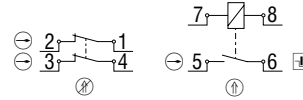

### Key

Positive break NC contact

Monitoring the interlock according to EN ISO 14119

Actuated

Not actuated



Information for the selection of suitable safety-monitoring modules can be found in the Schmersal catalogues or in the online catalogue on our website: [products.schmersal.com](http://products.schmersal.com).

### 5. Set-up and maintenance



The installation, operation and maintenance must be executed by qualified professionals. The requirements to be met for the installation and the maintenance can be found in this operating instructions manual. Do not expose the device to mechanical and/or thermal loads or stresses, which exceed the limits specified in the operating instructions manual. For the set-up and the operation of the safety switchgear, the applicable (also national) safety and accident prevention regulations as well as the generally acknowledged codes of practice of technology must be observed.

#### 5.1 Functional testing

The safety function of the safety components must be tested. The following conditions must be previously checked and met:

- The installation is executed according to the instructions
- The connection is executed correctly
- The cable is correctly executed and connected
- The sealing is correctly located in the enclosure.  
(Do not remove the sealing!)
- The safety component is not damaged
- Remove particles of dust and soiling
- Check cable entry and connections

#### 5.2 Maintenance

A regular visual inspection and functional test, including the following steps, is recommended:

1. Check the correct fixing of the safety switchgear, protective enclosure and actuator.
2. Remove particles of dust and soiling
3. Check cable entry and connections in a de-energised condition



Avoid electrostatic charging. Clean with damp cloth. Do not open the device when live.



Adequate measures must be taken to ensure protection against tampering either to prevent tampering of the safety guard, for instance by means of replacement actuators.

**For explosion protection reasons, the component must be exchanged after max. 1 million operations.**

**Damaged or defective components must be replaced.**

### 6. Disassembly and disposal

#### 6.1 Disassembly

The safety switchgear must be disassembled in a de-energised condition only.

#### 6.2 Disposal

The safety switchgear must be disposed of in an appropriate manner in accordance with the national prescriptions and legislations.

7. EU Declaration of conformity

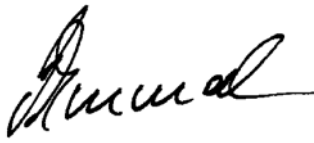
EU Declaration of conformity		
Translation of the original declaration of conformity	K.A. Schmersal GmbH & Co. KG Mödinghofe 30 42279 Wuppertal Germany Internet: www.schmersal.com	
We hereby certify that the hereafter described components both in their basic design and construction conform to the applicable European Directives.		
<b>Name of the component:</b>	EX-AZM170 EX-AZM170 I	
<b>Marking:</b>	⊕ II 3G Ex nC IIB T5 Gc ⊕ II 3D Ex tc IIIC T80°C Dc	
<b>Type:</b>	See ordering code	
<b>Description of the component:</b>	Interlocking device with electromagnetic interlock for safety functions	
<b>Relevant Directives:</b>	Machinery Directive 2006/42/EC EMC-Directive 2014/30/EU Explosion Protection Directive (ATEX) 2014/34/EU RoHS-Directive 2011/65/EU	
<b>Applied standards:</b>	EN 60947-5-1:2017 EN ISO 14119:2014 EN IEC 60079-0:2018 EN IEC 60079-15:2019 EN 60079-31:2014	
<b>Person authorised for the compilation of the technical documentation:</b>	Oliver Wacker Mödinghofe 30 42279 Wuppertal	
<b>Place and date of issue:</b>	Wuppertal, 10 May 2022	
		
	Authorised signature <b>Philip Schmersal</b> Managing Director	

EX-AZM170-A-EN



The currently valid declaration of conformity can be downloaded from the internet at [products.schmersal.com](http://products.schmersal.com).

