

操作与安装指示

电磁安全锁 AZM40Z-I2-ST-1P2P-DU

Table of Contents

1	About this document
1.1	Function
1.2	Target group of the operating instructions: authorised qualified personnel
1.3	Explanation of the symbols used
1.4	Appropriate use
1.5	General safety instructions
1.6	Warning about misuse
1.7	Exclusion of liability
2	Product description
2.1	Ordering code
2.2	Special versions
2.3	Purpose
2.4	Technical Data
3	Mounting
3.1	General mounting instructions
3.2	Manual release
3.3	Dimensions
4	Electrical connection
4.1	General information for electrical connection
4.2	Requirements for the connected safety-monitoring module
4.3	Wiring configuration and connector accessories
4.4	Wiring examples
5	Actuator teaching / actuator detection
6	Active principle and diagnostic functions
6.1	Magnet control
6.2	Mode of operation of the safety outputs
6.3	Diagnostic-LEDs
6.4	Diagnostic outputs
6.5	Diagnostic information
7	Set-up and maintenance
7.1	Functional testing
7.2	Maintenance
8	Disassembly and disposal
8.1	Disassembly
8.2	Disposal

1 About this document

1.1 Function

This document provides all the information you need for the mounting, set-up and commissioning to ensure the safe operation and disassembly of the switchgear. The operating instructions enclosed with the device must always be kept in a legible condition and accessible.

1.2 Target group of the operating instructions: authorised qualified personnel

All operations described in the operating instructions manual must be carried out by trained specialist personnel, authorised by the plant operator only.

Please make sure that you have read and understood these operating instructions and that you know all applicable legislations regarding occupational safety and accident prevention prior to installation and putting the component into operation.

The machine builder must carefully select the harmonised standards to be complied with as well as other technical specifications for the selection, mounting and integration of the components.

1.3 Explanation of the symbols used



Information, hint, note: This symbol is used for identifying useful additional information.



Caution: Failure to comply with this warning notice could lead to failures or malfunctions.

Warning: Failure to comply with this warning notice could lead to physical injury and/or damage to the machine.

1.4 Appropriate use

The Schmersal range of products is not intended for private consumers.

The products described in these operating instructions are developed to execute safety-related functions as part of an entire plant or machine. It is the responsibility of the manufacturer of a machine or plant to ensure the correct functionality of the entire machine or plant.

The safety switchgear must be exclusively used in accordance with the versions listed below or for the applications authorised by the manufacturer. Detailed information regarding the range of applications can be found in the chapter "Product description".

1.5 General safety instructions

The user must observe the safety instructions in this operating instructions manual, the country specific installation standards as well as all prevailing safety regulations and accident prevention rules.



Further technical information can be found in the Schmersal catalogues or in the online catalogue on the Internet: products.schmersal.com.

The information contained in this operating instructions manual is provided without liability and is subject to technical modifications.

There are no residual risks, provided that the safety instructions as well as the instructions regarding mounting, commissioning, operation and maintenance are observed.

1.6 Warning about misuse



In case of inadequate or improper use or manipulations of the component, personal hazards or damage to machinery or plant components cannot be excluded.

1.7 Exclusion of liability

We shall accept no liability for damages and malfunctions resulting from defective mounting or failure to comply with the operating instructions manual. The manufacturer shall accept no liability for damages resulting from the use of unauthorised spare parts or accessories.

For safety reasons, invasive work on the device as well as arbitrary repairs, conversions and modifications to the device are strictly forbidden, the manufacturer shall accept no liability for damages resulting from such invasive work, arbitrary repairs, conversions and/or modifications to the device.

2 Product description

2.1 Ordering code

Product type description: AZM40(1)-(2)-ST-1P2P-(3)	
(1)	
Z	Guard locking monitored 
B	Actuator monitored
(2)	
without	Standard coding
I1	Individual coding
I2	Individual coding, multiple teaching
(3)	
without	Counterbores for countersunk screws (standard)
PH	Flat enclosure for protruding screws
Actuator	AZM40-B1
	AZM40-B1-PH

2.2 Special versions

For special versions, which are not listed in the ordering code, these specifications apply accordingly, provided that they correspond to the standard version.

2.3 Purpose

The non-contact, electronic safety switchgear is designed for application in safety circuits and is used for monitoring the position and locking of movable safety guards.

The AZM40 interlock system is suitable for mounting to 40 mm profile systems and, thanks to the 180 degree angle flexibility of the actuator, for rotating and sliding guards. LEDs are visible from 3 sides.



The safety switchgears are classified according to EN ISO 14119 as type 4 interlocking devices. Designs with individual coding are classified as highly coded.

The different variants can be used as safety switch with interlocking function either as solenoid interlock.



If the risk analysis indicates the use of a **monitored interlock** then a variant with the monitored interlock is to be used, marked with the  symbol in the ordering code.

The actuator monitoring variant (B) is a safety switch with an interlock function for process protection.

The safety function consists of safely switching off the safety outputs when the safety guard is unlocked or opened and maintaining the safe switched off condition of the safety outputs for as long as the safety guard is open.

The AZM40 solenoid interlock is a bi-stable system, which means the interlock remains in the last position if power is lost.

Series-wiring

Series-wiring can be set up. In the case of a series connection, the risk time remains unchanged and the reaction time increases by the sum of the reaction time of the inputs per additional unit specified in the technical data. The quantity of devices is only limited by the cable drops and the external cable fuse protection, according to the technical data.



The user must evaluate and design the safety chain in accordance with the relevant standards and the required safety level. If multiple safety sensors are involved in the same safety function, the PFH values of the individual components must be added.



The entire concept of the control system, in which the safety component is integrated, must be validated to the relevant standards.

2.4 Technical Data

许可 - 标准

证书	TÜV cULus FCC IC UKCA ANATEL
----	---

总体数据

标准型	EN ISO 13849-1 EN ISO 14119 EN IEC 60947-5-3 EN IEC 61508
编码	单独编码, 多次示教
编码等级, 依据EN ISO 14119	高
工作原理	RFID
频段 RFID	125 kHz
发射器输出 RFID, 最大植	-6 dB/m
外壳材料	轻合金压铸件和塑料 (玻璃纤维增强热塑塑料, 自熄灭)
响应时间, 最大	100 ms
风险持续期, 最大	200 ms
响应时间, 通过安全输入关闭安全输出, 最大值	1.5 ms
毛重	304 g

总体数据 - 产品特性

电磁安全锁, 受监控	是
锁	是
手动解锁	是
短路检测	是
交叉电路检测	是
串联连接	是
安全功能	是
整个系统检测, 状态	是
安全触点数量	2

安全评估

标准型	EN ISO 13849-1 EN IEC 61508
-----	--------------------------------

安全评估 - 联锁

性能水平, 最高	e
类别	4
PFH值	1.10×10^{-10} /h
PPFD值	8.90×10^{-10}
安全完整性等级 (SIL), 停止 0, 适用于以下应用	3
任务时间	20 年

安全评估 - 防护锁定

性能水平, 最高	d
类别	2
PFH值	3.00×10^{-10} /h
PPFD值	2.40×10^{-10}
安全完整性等级 (SIL), 停止 0, 适用于以下应用	2
任务时间	20 年

机械参数

联锁原理	双稳定
机械寿命, 锁定周期	1,000,000 操作
机械寿命, 操动作循环	500,000 操作
注意 (机械寿命)	from device version V2 (V1 = 200.000 actuator cycles)
保持力 F_{Zh} 按照 EN ISO 14119	2,000 N
锁紧力 F_{max} , 最大	2,600 N
锁定力	40 N
注, (开锁力)	+/- 25%

操动速度, 最大	0.5 m/s
安装	安装孔 埋头孔
固定螺丝类型	2x M5
固定螺钉的紧固力矩, 最低限度	4 Nm
固定螺钉的紧固力矩, 最大值	6 Nm
注意	注意所用固定螺钉的最大拧紧扭矩。

机械参数 – 开关距离根据 EN IEC 60947-5-3

肯定开关距离 "ON" S_{ao}	1 mm
肯定闭合距离 "OFF" S_{ar}	8 mm

机械参数 – 连接技术

传感器链长度, 最大	30 m
注意 (传感器链长度)	根据输出电流, 电缆长度和电缆截面会改变电压降
注意 (串联连接)	设备数量不限, observe 外部线路熔断, 最多可连接 31 台设备。在串行诊断 SD 的情况下, 最多可连接 31 台设备
连接器	连接器M12, 8芯, A编码

机械参数 – 尺寸

传感器长度	119.5 mm
传感器宽度	40 mm
传感器高度	20 mm

环境条件

防护等级	IP66 IP67 IP69
工作环境温度	-20 ... +55 ° C
储存和运输温度	-40 ... +85 ° C
最大相对湿度	93 %
注 (相对湿度)	无冷凝 不结冰
抗振动	10 ... 55 Hz, 振幅 1 mm
耐冲击	30 g / 11 ms
防护等级	III
最大允许安装海拔高度	2,000 m

环境条件 – 绝缘值

额定绝缘电压 U_i	32 VDC
额定冲击耐受电压 U_{imp}	0.8 kV
过电压级别	III

电气参数

工作电压	24 VDC -15 % / +10 %
空载电源电流 I_0 , 典型	100 mA
开关瞬间的电流消耗磁铁, 峰值	600 mA / 100 ms
额定工作电压	24 VDC
工作电流	1,200 mA
要求额定短路电流	100 A
外部电线和设备保险丝额定值	2 A gG
准备就绪时间, 最大	4,000 ms
转换频率, 最大	0.25 Hz
应用类别 DC-12	24 VDC / 0.05 A
电气保险丝容量, 最大	2 A

电气参数 - 线圈控制

指定, 线圈控制	IN
开关阈值	-3 V ... 5 V (Low) 15 V ... 30 V (High)
磁铁闭合时间	100 %
测试脉冲持续时间, 最大	5 ms
测试脉冲间隔, 最低限度	40 ms
分类 ZVEI CB24I, 接收器	C0
分类 ZVEI CB24I, 信号源	C1 C2 C3
24V时, 电流消耗, 最小	10 mA
24V时, 电流消耗, 最大	15 mA

电子参数 - 安全数字输入

指定, 安全输入	X1 和 X2
开关阈值	3 V ... 5 V (Low) 15 V ... 30 V (High)
24V时, 电流消耗	5 mA
测试脉冲持续时间, 最大	1 ms
测试脉冲间隔, 最低限度	100 ms
分类 ZVEI CB24I, 接收器	C1
分类 ZVEI CB24I, 信号源	C1 C2 C3

电气参数 - 安全数字输出

指定, 安全输出	Y1和Y2
----------	-------

额定工作电流（安全输出）	250 mA
控制元件的设计	短路保护，P型
电压降 U_d ，最大电压降 U_d ，最大	2 V
泄漏电流 I_r ，最大植	0.5 mA
电压，应用类别 DC-12	24 VDC
电流，应用类别 DC-12	0.25 A
电压，应用类别 DC-13	24 VDC
电流，应用类别 DC-13	0.25 A
测试脉冲间隔，典型	1000 ms
测试脉冲持续时间，最大	0.5 ms
分类 ZVEI CB24I，信号源	C2
分类 ZVEI CB24I，接收器	C1 C2

电气参数 - 诊断输出

指定， 诊断输出	OUT
控制元件的设计	短路保护，P型
电压降 U_d ，最大电压降 U_d ，最大	2 V
电压，应用类别 DC-12	24 VDC
电流，应用类别 DC-12	0.05 A
电压，应用类别 DC-13	24 VDC
电流，应用类别 DC-13	0.05 A

状态显示

注（LED开关状态显示）	工作状态：LED绿色 错误 / 功能故障：LED红色 供电电压 UB：LED 绿色
--------------	---

引脚分配

PIN 1	A1 电源电压 UB
PIN 2	X1 安全输入 1
PIN 3	A2 GND
PIN 4	Y1 安全输出 1
PIN 5	OUT 监控输出
PIN 6	X2 安全输入 2
PIN 7	Y2 安全输出 2
PIN 8	IN 线圈控制

Note about the safety classification



The safety classification of the guard locking function only applies for standard devices with monitored solenoid interlock AZM40Z-...-1P2P-... (see Ordering code).



The actuation of the interlock must be compared externally with the OSSD release. If a shut-down now occurs due to an unintentional unlocking this is detected by an external diagnostic.



The safety analysis of the guard locking function refers to the component solenoid interlock AZM as part of the complete system.

On the customer side further measures such as safe actuation and safe cable installation to prevent faults are to be implemented.

In the event of a fault resulting in the unlocking of the guard locking, this is detected by the solenoid interlock and the safety gates Y1/Y2 switch off. When such a fault occurs the protection equipment may open immediately, just once, before the safe condition of the machine is reached. The system reaction of category 2 allows that a fault can occur between tests causing the loss of the safety function which is detected by the test.

FCC/IC – Note

This device complies with Part 15 of the FCC Rules and contains licence-exempt transmitter/receivers that are compliant with ISSED (Innovation, Science and Economic Development) Canada licence-exempt RSS standard(s).

Operation is subject to the following two conditions:

- (1) This device may not cause harmful interference signals, and
- (2) This device must be able to tolerate interference signals. These also include interference signals that could cause the device to function improperly.

This device complies with the nerve stimulation limits (ISED SPR-002) when operated at a minimum distance of 100 mm. Changes or modifications not expressly approved by K.A. Schmersal GmbH & Co. KG could void the user's authority to operate the equipment.

The licence-free transmitter/receiver contained in this device satisfies the requirements of the "Radio Standards Specification" of the Innovation, Science and Economic Development Canada (ISED) authority that apply to licence-free radio equipment. Operation is permissible under the following two conditions:

- (1) The device must not create disturbances.
- (2) The device must tolerate received radio frequency interference, even if this could impair its functionality.

This device complies with the nerve stimulation limits (ISED CNR-102) when operated at a minimum distance of 100 mm. In the event of changes or modifications that have not been expressly approved by K.A. Schmersal GmbH & Co. KG, the user's authorisation to use the device may become ineffective.



Este equipamento não tem direito à proteção contra interferência prejudicial e não pode causar interferência em sistemas devidamente autorizados.

Para maiores informações consultar: www.gov.br/anatel

3 Mounting

3.1 General mounting instructions



Please observe the remarks of the standards EN ISO 12100, EN ISO 14119 and EN ISO 14120.

Any position is possible.

The solenoid interlock must not be used as an end stop.

The transport lock must be removed.

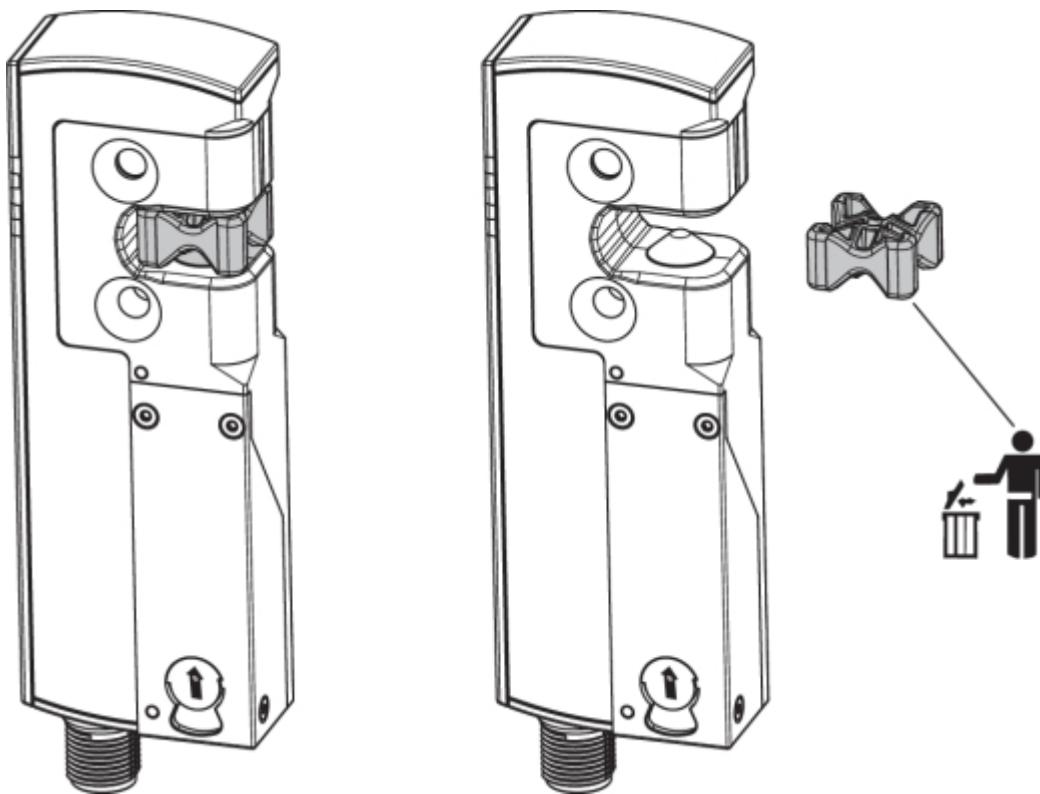

For attachment of the solenoid interlock and the actuator, two mounting holes for M5 screws are provided.



The M5 screws must be at least strength class 8.8 or, in stainless steel, strength class 80. The tightening torque of the M5 screws is 4 ... 6 Nm, the maximum tightening torque depends on the fastening screws used.



The solenoid interlock is self-greasing. The grease on the locking bolt and in the actuator recess must not be removed.



The accumulation of fine-grained dirt in the bolt area must be avoided. In that case, mounting where the bolt goes upwards from below is not advisable. The actuator must be mounted so that it is protected from damage due to external influences.



Use in temperatures below freezing is permitted only with dry cold. The customer must take this into account when assembling the safety switch.



The interlock with locking bolt (A) and actuator with triangular marking (B) must be installed in the same installation direction.

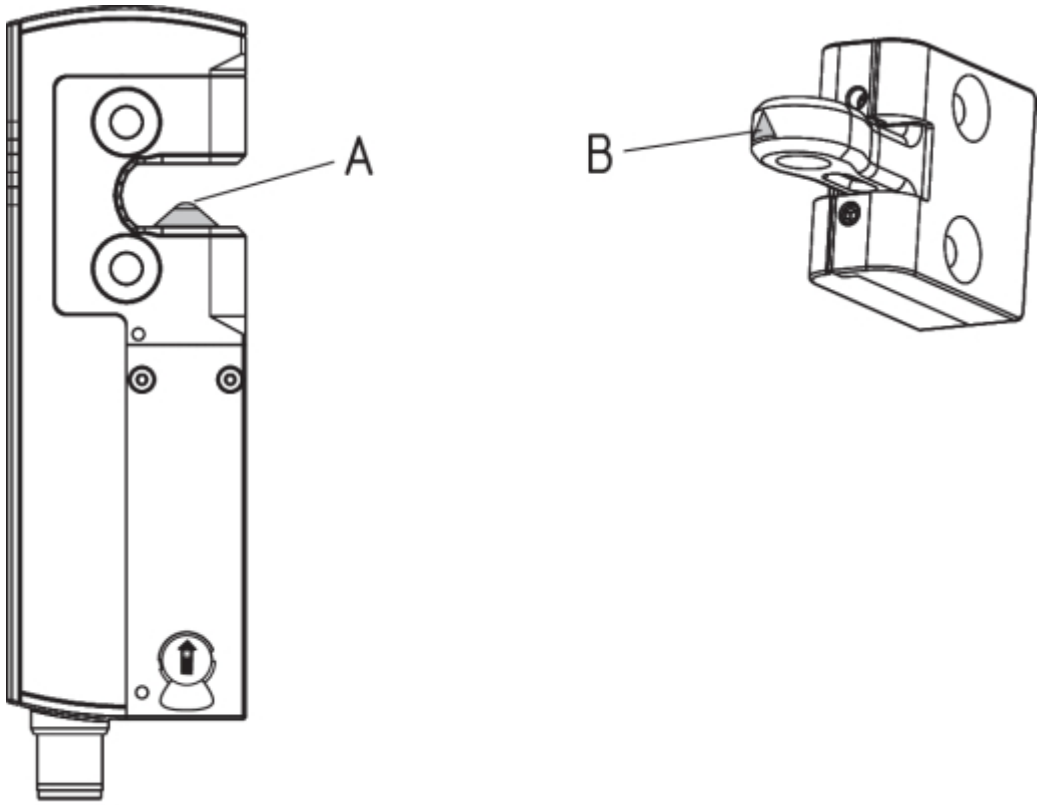

Actuation direction

The actuator can be continuously inserted by 180° .

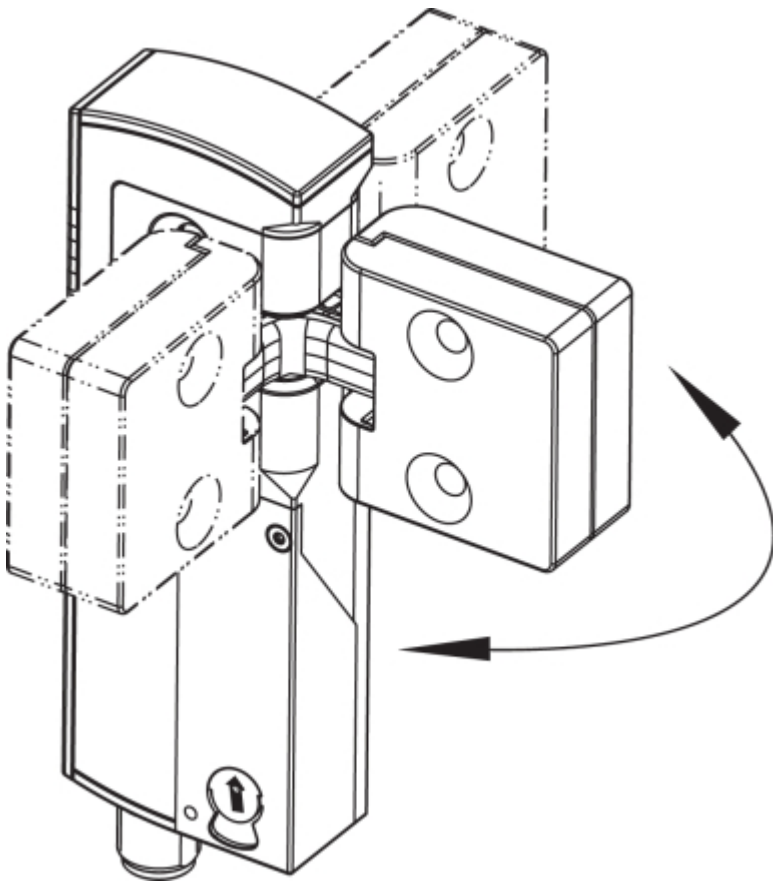



The actuator must be permanently fitted to the safety guards and protected against displacement by suitable measures (tamperproof screws, gluing, drilling of the screw heads).

Authorised actuator and interlock offset

Tilt angle

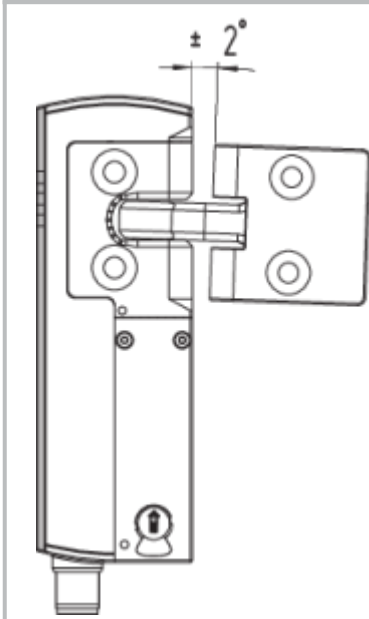

Rotating angle



Actuating directions and switch distances

The AZM40 can be operated within the following tolerance limits:

X axis	- 3 mm	
Y axis	± 1 mm	
Z axis	± 1.5 mm (actuator in centre position)	

Adjustment

The two hexagon socket screws M4 can be used to adjust the actuator tongue in the X direction, using a hexagonal key wrench AF 2 mm.

Adjustment via hexagon socket screws M4Local

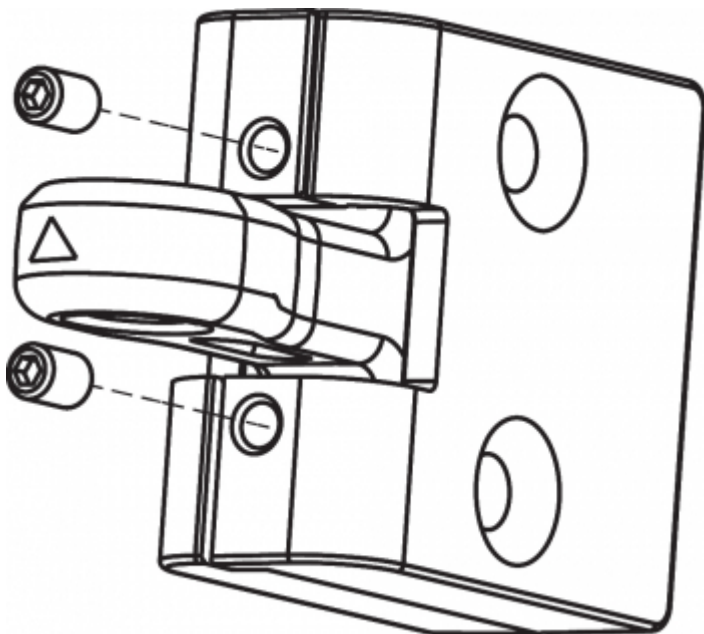

The hexagon socket screws must not be completely unscrewed.

To avoid any interference inherent to this kind of system and any reduction of the switching distances, please observe the following guidelines:

- Metal parts and magnetic fields in the area of the solenoid interlock and the actuator can influence the switch distance or lead to malfunctions
- Keep away from metal chips

Minimum distance between AZM40 solenoid interlocks (in mm)

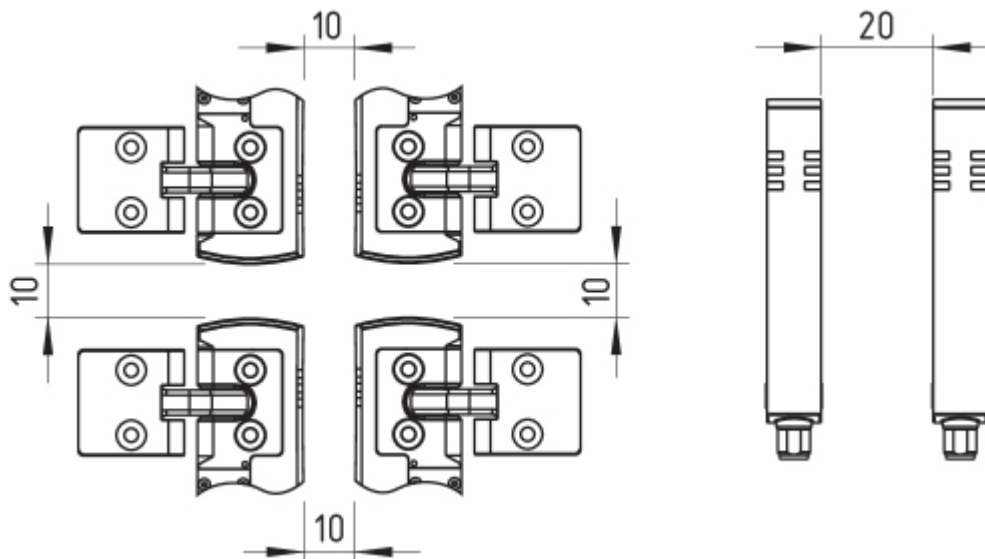

3.2 Manual release

For installation and maintenance, the solenoid interlock can be unlocked in a de-energised condition. The solenoid interlock is unlocked by turning the auxiliary release anti-clockwise. The normal locking function is only restored after the manual release has been returned to its original position.



Do not turn the manual release beyond the end stop.

A tool is required to operate the manual release (recommendation: slotted screwdriver 0.8 x 4 ... 4.5 mm).

The manual release must be protected against accidental actuation, e.g. by using the enclosed seal after completing commissioning.

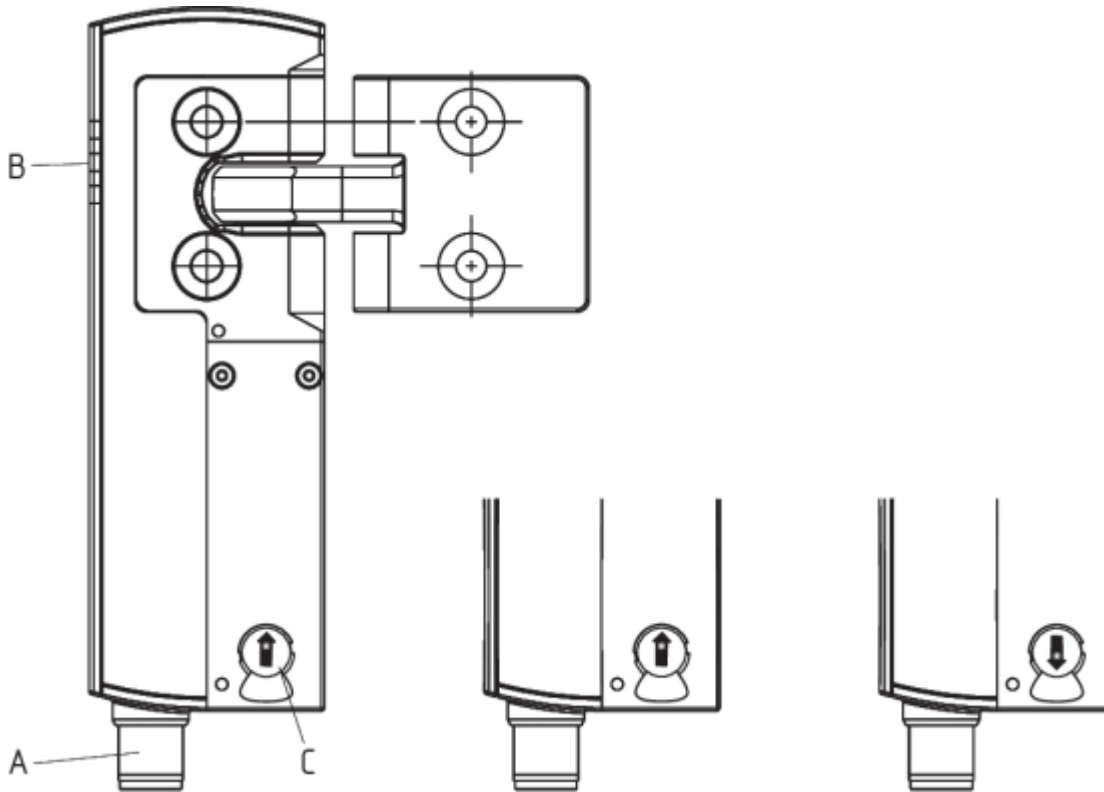

Key	
A	Connector plug M12, 8-pole
B	LED indications
C	Manual release (on both sides)
	Solenoid interlock ready for operation
	Solenoid interlock not ready for operation

3.3 Dimensions

All measurements in mm.

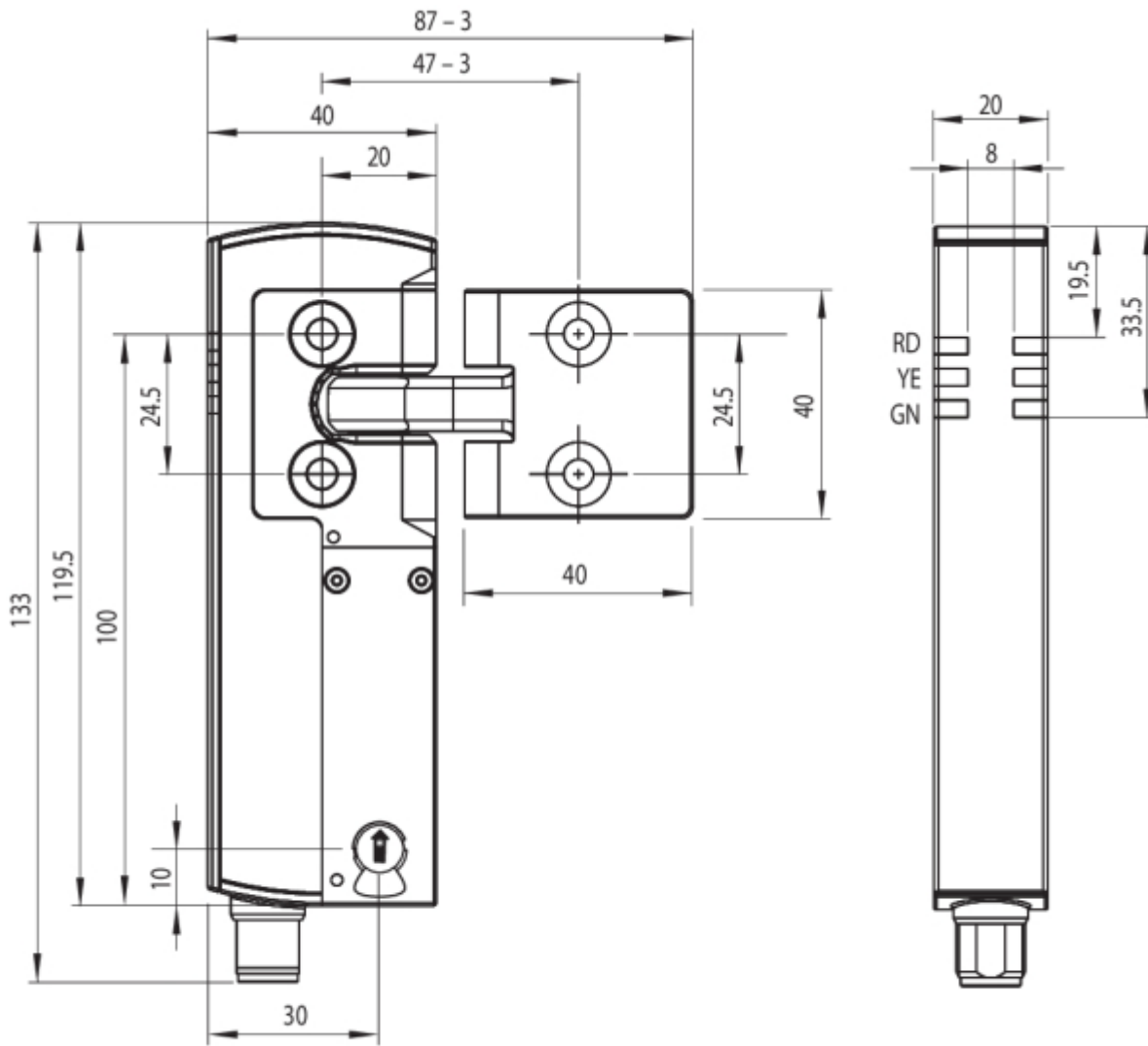

Optional system components

Retrofit kit emergency exit/emergency release

The retrofit kit is used for subsequent functional expansion of the solenoid interlock.

<input type="checkbox"/>	Designation	Ordering code
Emergency exit	ACC-AZM40-LEV-T	103054265
Emergency release	ACC-AZM40-LEV-N	103054268
Emergency exit with pushbutton - for 40 mm profiles - for profiles up to 170 mm	ACC-AZM40-PT-T-40MM ACC-AZM40-PT-T-170MM	103054271 103054273
Emergency release with push button - for 40 mm profiles - for profiles up to 170 mm	ACC-AZM40-PT-N-40MM ACC-AZM40-PT-N-170MM	103054275 103054277

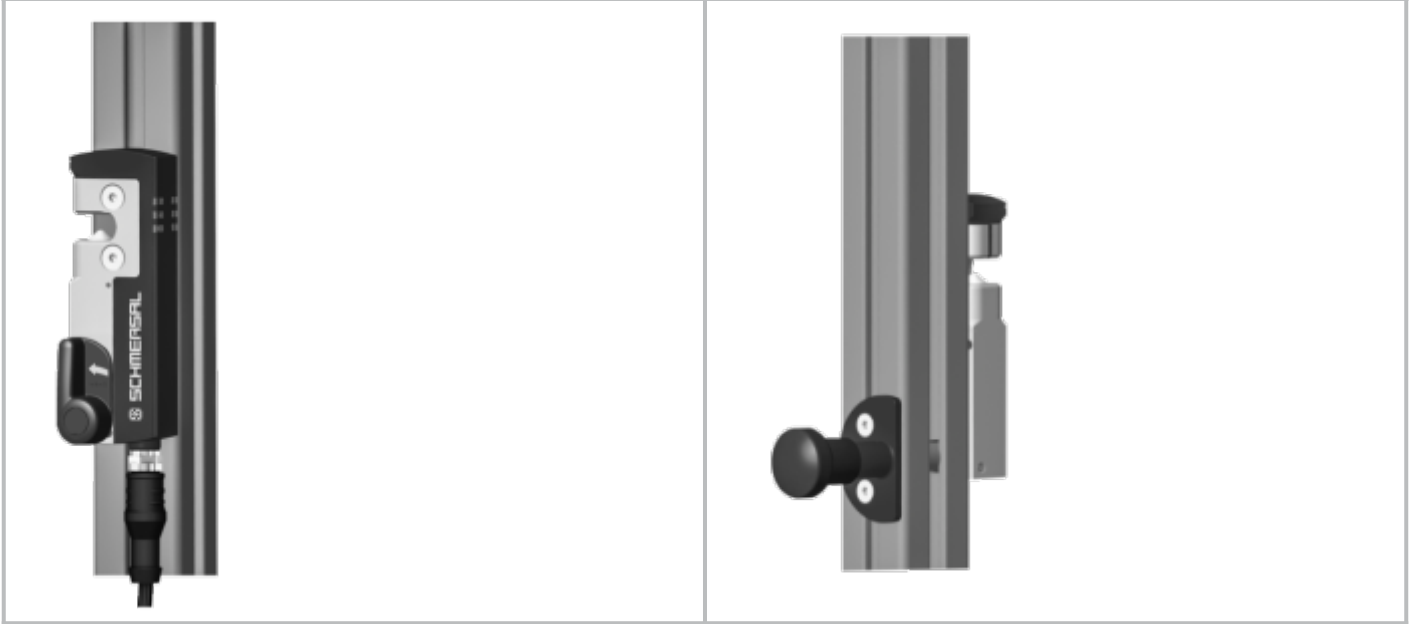

<input type="checkbox"/>	Designation	Ordering code
Lockout device	SZ40	103053182
Universal mounting plate, for 20, 30, 45, 50 and 60 mm profile systems, 2 pcs.	MP-AZM40	103045324
Tamper-proof screws M5 x 25, flat head, 2 pcs.	ACC-NRS-M5X25-FHS-2PCS	103045415
Tamper-proof screws M5 x 25, countersunk head, 2 pcs.	ACC-NRS-M5X25-CSS-2PCS	103045416

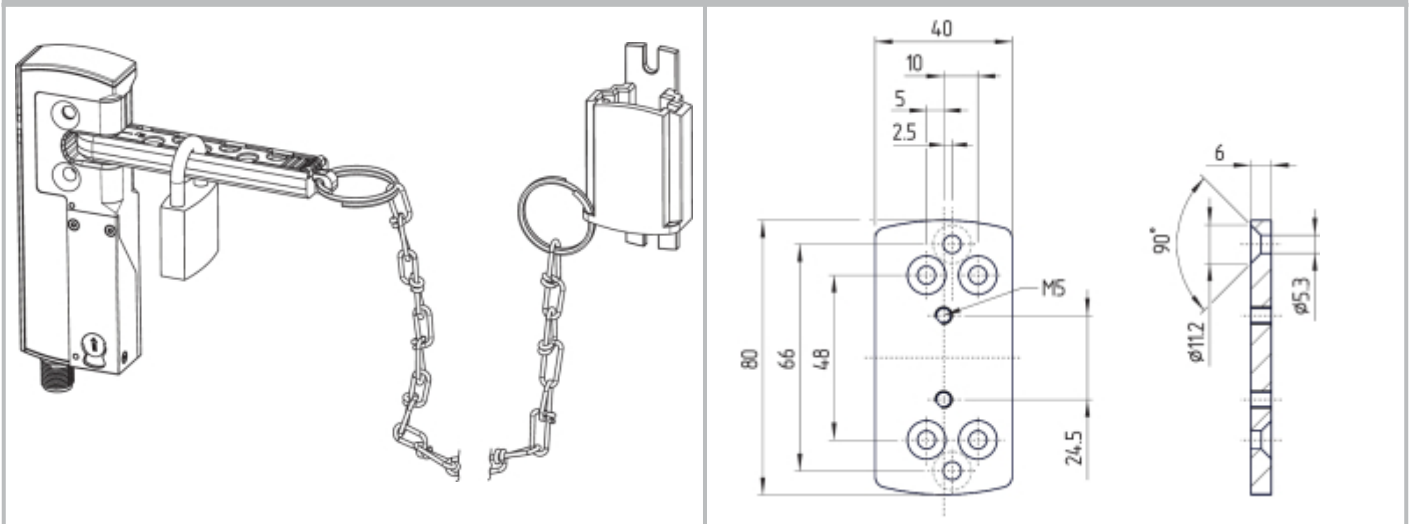

4 Electrical connection

4.1 General information for electrical connection



The electrical connection may only be carried out by authorised personnel in a de-energised condition.

The voltage inputs A1, X1, X2 and IN must have a protection against permanent overvoltage. Supply units according to EN 60204-1 is recommended.

The required electrical cable fuse protection must be integrated in the installation.

The safety outputs can be integrated into the safety circuit of the control system.

4.2 Requirements for the connected safety-monitoring module

Dual-channel safety input, suitable for 2 p-type semi-conductor outputs (OSSD)



Safety controller configuration

If the safety switchgear is connected to electronic safety-monitoring modules, we recommend that you set a discrepancy time of at least 100 ms. The safety inputs of the safety-monitoring module must be able blanking a test impulse of approx. 1 ms. The safety-monitoring module does not need to have a cross-wire short monitoring function, if necessary, the cross-wire short monitoring function must be disabled.



Information for the selection of suitable safety-monitoring modules can be found in the Schmersal catalogues or in the online catalogue on the Internet: products.schmersal.com

4.3 Wiring configuration and connector accessories

Function safety switchgear	<input type="checkbox"/>	<input type="checkbox"/>	Pin configuration of the connector	Colour code of conductor numbering of Schmersal connector plugs		Poss. Colour code of other commercially available connector plugs according to EN 60947-5-2
<input type="checkbox"/>	With conventional diagnostic output			P67 / IP69 acc. DIN 47100	IP69 (PVC)	
A1	Ue		1	WH	BN	BN
X1	Safety input 1		2	BN	WH	WH
A2	GND		3	GN	BU	BU
Y1	Safety output 1		4	YE	BK	BK
OUT	Diagnostic output		5	GY	GY	GY
X2	Safety input 2		6	PK	VT	PK
Y2	Safety output 2		7	BU	RD	VT
IN	Magnet control		8	RD	PK	OR

Accessories Pre-wired cables

Pre-wired cables with socket (female)
M12, 8-pole - 8 x 0.25 mm² IP67 / IP69

Cable length	Ordering code
2.5 m	103011415
5.0 m	103007358
10.0 m	103007359
15.0 m	103011414

Connecting cables (PVC) with socket (female)
M12, 8-pole - 8 x 0.21 mm² IP69

Cable length	Ordering code
5.0 m	101210560
5.0 m, angled	101210561
10.0 m	103001389
15.0 m	103014823

Further versions in other lengths and with angled cable exit are available upon request.



When using an angled connector, it is aligned parallel to the attachment surface and points to the side away from the actuator.

AZM40

AZM40-B1

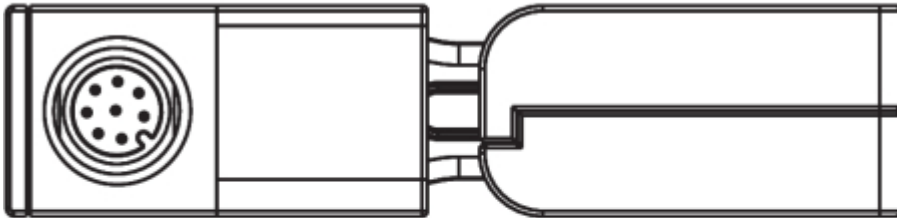

4.4 Wiring examples

The application examples shown are suggestions. They however do not release the user from carefully checking whether the switchgear and its set-up are suitable for the individual application. The application examples shown are suggestions.

Wiring example: Series-wiring AZM40

The voltage is supplied at both safety inputs of the terminal safety component of the chain (considered from the safety-monitoring module). The safety outputs of the first safety component are wired to the safety-monitoring module.

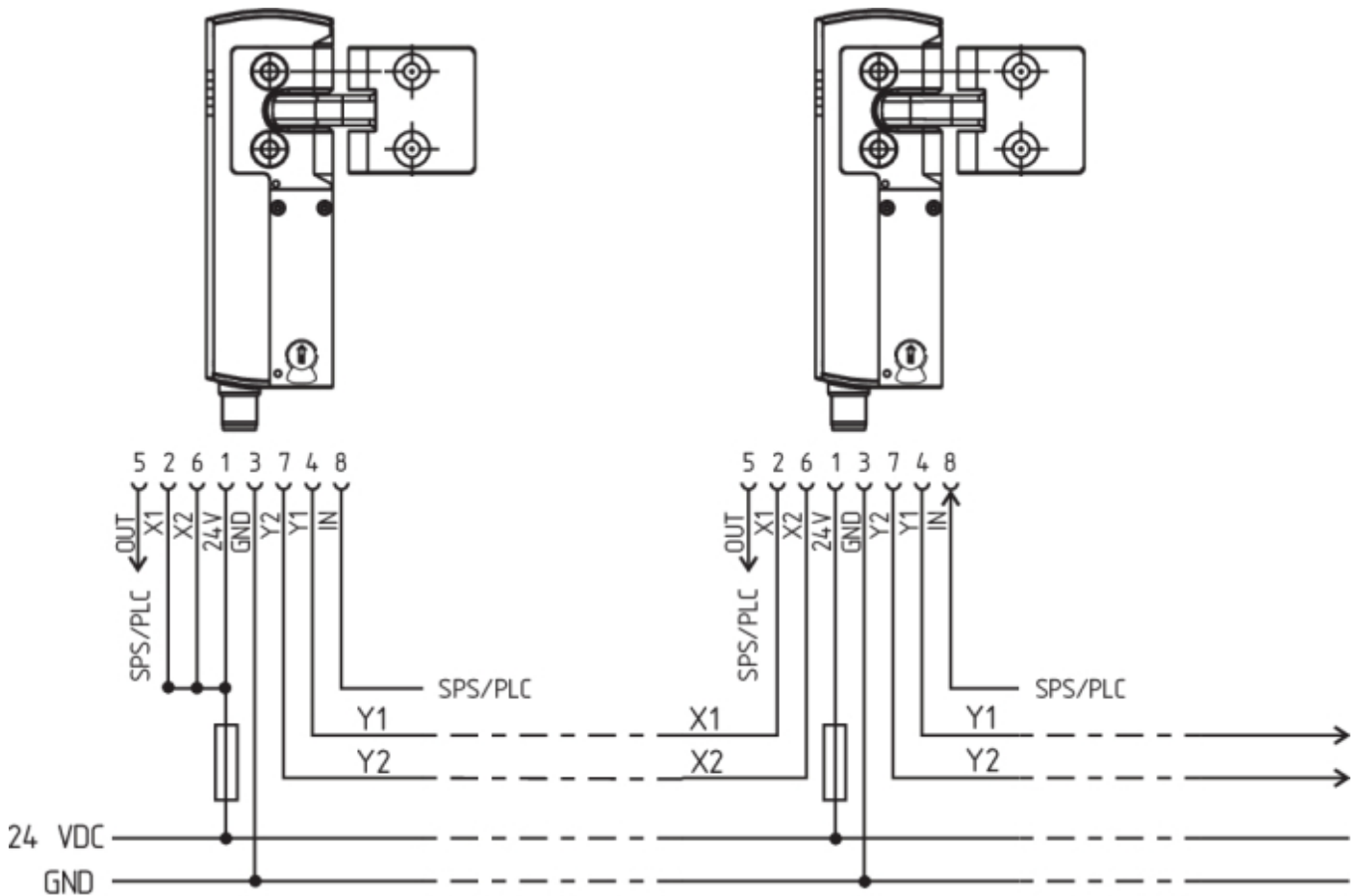

Y1 and Y2 = Safety outputs → Safety monitoring module

5 Actuator teaching / actuator detection

Solenoid interlocks with standard coding are ready to use upon delivery.

Individually coded solenoid interlocks and actuators will require the following "teach-in" procedure:

1. Switch the solenoid interlock's voltage supply off and back on.
2. Introduce the actuator in the detection range. The teach-in procedure is signalled at the solenoid interlock, green LED off, red LED on, yellow LED flashes (1 Hz).
3. After 10 seconds, brief yellow cyclic flashes (3 Hz) request the switch-off of the operating voltage of the solenoid interlock. (If the voltage is not switched off within 5 minutes, the solenoid interlock cancels the "teach-in" procedure and signals a false actuator by 5 red flashes.)
4. Once the operating voltage is switched back on, the actuator must be detected once more in order to activate the actuator code that has been taught in. In this way, the activated code is definitively saved!

For ordering suffix -I1, the executed allocation of safety switchgear and actuator is irreversible.

For ordering suffix -I2, the "teach-in" procedure for a new actuator can be repeated an unlimited number of times.

When a new actuator is taught, the code, which was applicable until that moment, becomes invalid. Subsequent to that, an enabling inhibit will be active for ten minutes, thus providing for an increased protection against tampering. The green LED will flash until the expiration of the time of the enabling inhibit and the detection of the new actuator.

In case of power failure during the lapse of time, the 10-minute tampering protection time will restart.

6 Active principle and diagnostic functions

6.1 Magnet control

The bistable interlock is released through operational setting of the IN signal (= 24 V). If the IN signal is not set (= 0 V), the solenoid interlock goes into locked state, so long as the correct actuator is inserted into the solenoid interlock.

6.2 Mode of operation of the safety outputs

In the standard AZM 40Z variant, the unlocking of the solenoid interlock causes the safety outputs to be disabled. The unlocked safety guard can be relocked as long as the actuator is inserted in the AZM 40Z solenoid interlock; in that case, the safety outputs are re-enabled.

The safety guard must not be opened.

In the AZM40B version, only the opening of the safety guard causes the safety outputs to be disabled.

If the safety outputs are already enabled, any error that does not immediately affect the functionality of the solenoid interlock (e.g. too high an ambient temperature, interference potential at the safety outputs, cross-wire short) will lead to a warning message, the disabling of the diagnostic output and the delayed shutdown of the safety outputs. The safety outputs are disabled if the error warning is active for 30 minutes. The signal combination, diagnostic output disabled and safety channels still enabled, can be used to stop the production process in a controlled manner. After the rectification of the error, the error message is reset by opening the corresponding safety guard.

6.3 Diagnostic-LEDs

The solenoid interlock signals the operating condition, as well as errors through 3-colour LEDs.

green (Power)	Supply voltage on
yellow (Status)	Operating condition
red (Fault)	Error (see table 2: Error messages / flash codes red diagnostic LED)

The green LED indicates that the safety sensor is ready for operation. The supply voltage is on and all safety inputs are present. Flashing (1Hz) of the green LED signals that a voltage is missing on one or both of the safety inputs (X1 and/or X2).

System condition No input signal at X1 and/or X2	LED		
	green	red	yellow
Safety guard open and a safety guard in the safety circuit upstream is also open	Flashes (1 Hz)	Off	Off
Safety guard closed and a safety guard in the safety circuit upstream is open	Flashes (1 Hz)	Off	Flashes
Safety guard locked and a safety guard in the safety circuit upstream is open	Flashes (1 Hz)	Off	On

6.4 Diagnostic outputs

The short-circuit proof diagnostic output OUT can be used for central visualisation or control tasks, e.g. in a PLC.

The diagnostic output is not a safety-related output.

Error warning

A fault has occurred, which causes the safety outputs to be disabled after 30 minutes (LED "fault" flashes, see Table 2). The safety outputs initially remain enabled (max. 30 minutes). This enables the shutdown of the process in a controlled manner. An error warning is deleted when the cause of error is eliminated.

Error

Errors, which no longer guarantee the safe function of the solenoid interlock (internal errors) cause the safety outputs to be immediately disabled. Any error that does not immediately affect the safe functionality of the solenoid interlock (e.g. excess ambient temperature, safety output to external potential, short circuit) will lead to a delayed shut-down (refer to table 2). After the rectification of the error, the error message is reset by opening the corresponding safety guard.



Forced opening of the solenoid interlock is indicated by synchronised flashing of all LEDs. The solenoid interlock and actuator must then be replaced.



Automatic, electronic locking takes place if more than one fault is detected at the safety outputs or a cross circuit is detected between Y1 and Y2. This means that normal fault acknowledgement is no longer possible. To reset this type of interlock, the solenoid interlock must be isolated from the supply voltage after elimination of the error causes.

Behaviour of the diagnostic output using the example of actuator-monitored guard locking

Sequence, blocking signal is applied after the door is closed

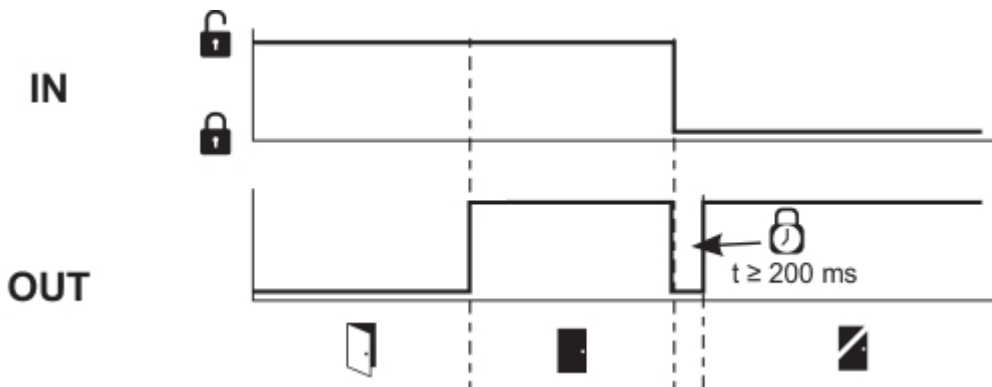

Sequence, locking signal is applied before the door is closed

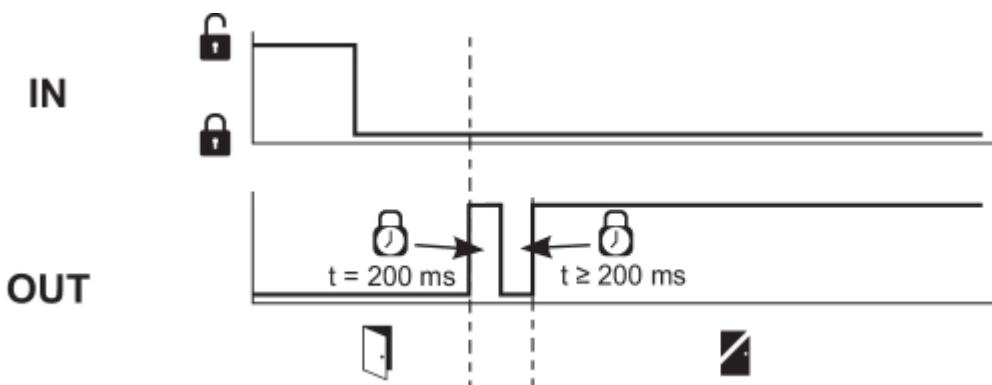

Disrupted process, door could not be locked or error

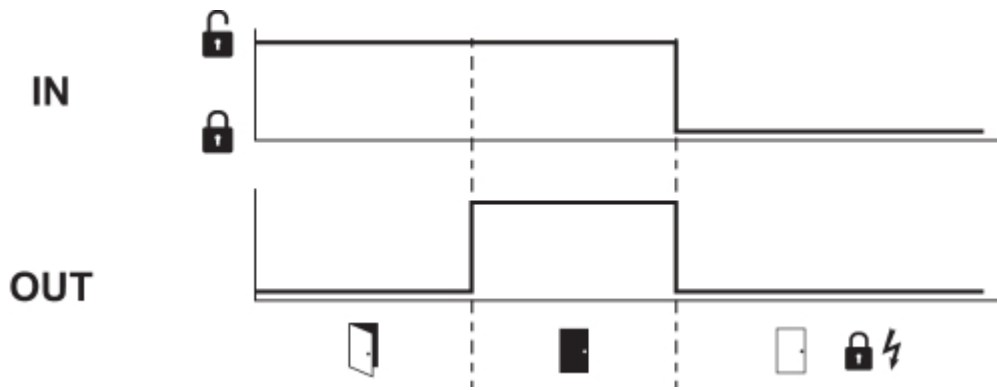

Normal sequence, door was unlocked

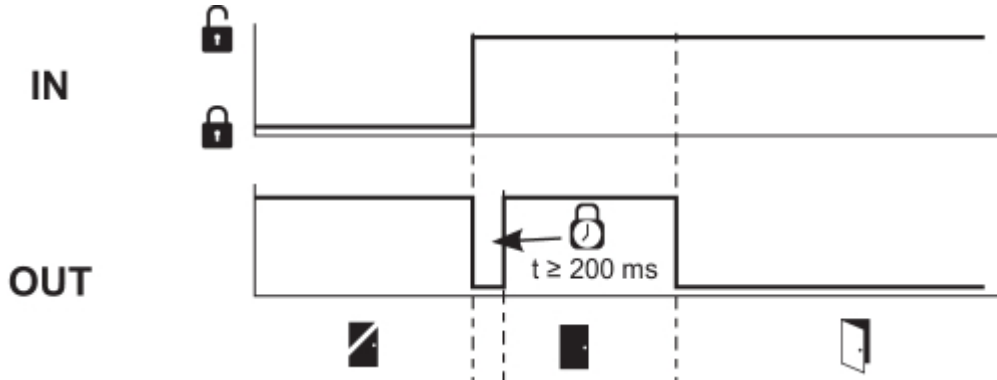

Sequence, door opened immediately after unlocking

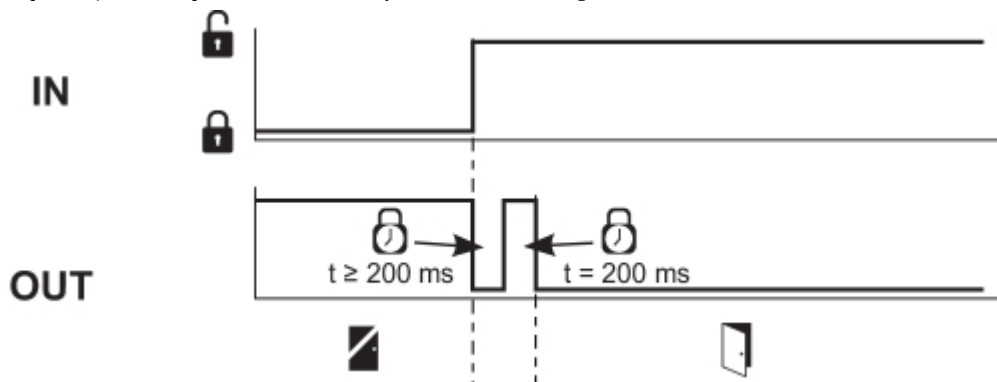

Disrupted process, door could not be unlocked

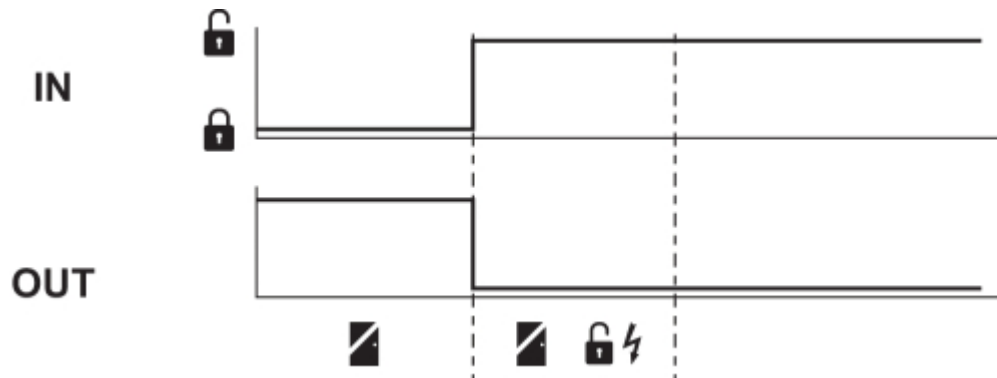

Key



Lock



Unlock



Locking time



Door open



Safety guard closed



Safety guard not locked or fault



Safety guard locked

6.5 Diagnostic information

Table 1: Diagnostic information of the safety switchgear

System condition	Magnet control (bistable) IN	LED			Safety outputs Y1, Y2		Diagnostic output OUT
		green	red	yellow	AZM40Z	AZM40B	
<input type="checkbox"/>	<input type="checkbox"/>						<input type="checkbox"/>
Door open	24 V	On	Off	Off	0 V	0 V	0 V
Door closed, not locked	24 V	On	Off	Flashes	0 V	24 V	24 V
Door closed, locking impossible	0 V	On	Flashes ²⁾	Flashes	0 V	24 V	0 V
Door closed and locked	0 V	On	Off	On	24 V	24 V	24 V
Error warning ¹⁾	0 V / 24 V	On	Flashes ²⁾	Flashes	24 V / 0 V	24 V ¹⁾	0 V
Error	0 V / 24 V		Flashes ²⁾		0 V	0 V	0 V
Mechanical overload fault ³⁾	0 V	flashes synchronously	flashes synchronously	flashes synchronously	0 V	0 V	0 V
Error in input circuit X1 and/or X2	0 V / 24 V	Flashes	Off	s. Section Diagnostic-LEDs	depending on the system status		
Advance warning level Service life (95% Service life)	0 V / 24 V	flashes synchronously	flashes synchronously	on / flashes / off	depending on the system status		
Maximum service life achieved	0 V / 24 V	flashes alternately	flashes alternately	Off	0 V	0 V	0 V
Additionally for variant I1/I2:							
Teach-in procedure actuator started	24 V	Off	On	Flashes	0 V	0 V	0 V
Only I2: teach-in procedure actuator (release block)	24 V	Flashes	Off	Off	0 V	0 V	0 V
¹⁾ after 30 min: switch-off due to error ²⁾ s. Flash code ³⁾ In the event of complaints relating to the mechanical overload fault, the device including the associated actuator must always be sent in.							

Table 2: Error messages / flash codes red diagnostic LED

Flash codes (red)	Designation	Autonomous switch-off after	Error cause
1 flash pulse	Error (warning) at output Y1	30 min	Fault in output test or voltage at output Y1, although the output is disabled.
2 flash pulses	Error (warning) at output Y2	30 min	Fault in output test or voltage at output Y2, although the output is disabled.
3 flash pulses	Error (warning) cross-wire short	30 min	Cross-wire short between the output cables or fault at both outputs
4 flash pulses	Error (warning) temperature too high	30 min	The temperature measurement reveals an internal temperature that is too high
5 flash pulses	Actuator fault	0 min	Incorrect or defective actuator
6 flash pulses	Internal error	0 min	Error at control inputs
7 flash pulses	Error, interlock actuator	0 min	Locking / unlocking blocked / incorrect position of manual release (at one of the two sides)
8 flash pulses	Error (warning) over/under voltage	30 min	Supply voltage outside specification
Continuous red	Internal error	0 min	Device defective

7 Set-up and maintenance

7.1 Functional testing

The safety function of the safety components must be tested. The following conditions must be previously checked and met:

1. Fitting and integrity of the cable connections.
2. Check the switch enclosure for damages
3. Remove particles of dust and soiling.

7.2 Maintenance

In the case of correct installation and intended use, the safety switchgear is maintenance-free. A regular visual inspection and functional test, including the following steps, is recommended:

1. Check for a secure installation of the actuator and the solenoid interlock.
2. Check max. misalignment of actuator unit and solenoid interlock and max. tipping and rotary angle and adjust using M4 socket head screws, if necessary.
3. Fitting and integrity of the cable connections.
4. Check the switch enclosure and actuator for damages.
5. Remove particles of dust and soiling.



Adequate measures must be taken to ensure protection against tampering either to prevent tampering of the safety guard, for instance by means of replacement actuators.



Damaged or defective components must be replaced.



After reaching a service life of 1,000,000 locking cycles or 500,000 actuator cycles (as of version "V2", see type plate), the solenoid interlock can no longer be locked and must be replaced, together with the actuator.

8 Disassembly and disposal

8.1 Disassembly

The safety switchgear must be disassembled in a de-energised condition only.

8.2 Disposal



The safety switchgear must be disposed of in an appropriate manner in accordance with the national prescriptions and legislations.